

## Access & Power Integration

### Altronix Trove2/Mercury Kits with Fused Outputs

#### 4 Door Kits:

##### T2MK3F4V

Fully assembled kit includes:

- Trove2 enclosure with TM2 Altronix/Mercury backplane
- (1) eFlow6NBV - Power Supply/Charger
- (1) ACM4 - Fused Access Power Controller
- (1) VR6 - Voltage Regulator
- (1) PDS8 - Dual Input Power Distribution Module

##### T2MK3F4QV

Fully assembled kit includes:

- Trove2 enclosure with TM2 Altronix/Mercury backplane
- (1) eFlow6NBV - Power Supply/Charger
- (1) LINQ2 - Network Communications Module
- (1) ACM4 - Fused Access Power Controller
- (1) VR6 - Voltage Regulator
- (1) PDS8 - Dual Input Power Distribution Module

#### 8 Door Kits:

##### T2MK3F8V

Fully assembled kit includes:

- Trove2 enclosure with TM2 Altronix/Mercury backplane
- (1) eFlow6NBV - Power Supply/Charger
- (1) ACM8 - Fused Access Power Controller
- (1) VR6 - Voltage Regulator
- (1) PDS8 - Dual Input Power Distribution Module

##### T2MK3F8QV

Fully assembled kit includes:

- Trove2 enclosure with TM2 Altronix/Mercury backplane
- (1) eFlow6NBV - Power Supply/Charger
- (1) LINQ2 - Network Communications Module
- (1) ACM8 - Fused Access Power Controller
- (1) VR6 - Voltage Regulator
- (1) PDS8 - Dual Input Power Distribution Module

##### T2MK7F8V

Fully assembled kit includes:

- Trove2 enclosure with TM2 Altronix/Mercury backplane
- (1) eFlow104NBV - Power Supply/Charger
- (1) ACM8 - Fused Access Power Controller
- (1) VR6 - Voltage Regulator
- (1) PDS8 - Dual Input Power Distribution Module

##### T2MK7F8QV

Fully assembled kit includes:

- Trove2 enclosure with TM2 Altronix/Mercury backplane
- (1) eFlow104NBV - Power Supply/Charger
- (1) LINQ2 - Network Communications Module
- (1) ACM8 - Fused Access Power Controller
- (1) VR6 - Voltage Regulator
- (1) PDS8 - Dual Input Power Distribution Module

#### 16 Door Kits:

##### T2MK75F16V

Fully assembled kit includes:

- Trove2 enclosure with TM2 Altronix/Mercury backplane and TMV2 door backplane
- (1) eFlow104NBV and (1) eFlow102NBV - Power Supply/Chargers
- (2) ACM8 - Fused Access Power Controllers
- (1) PD16W - Power Distribution Module

##### T2MK75F16QV

Fully assembled kit includes:

- Trove2 enclosure with TM2 Altronix/Mercury backplane and TMV2 door backplane
- (1) eFlow104NBV and (1) eFlow102NBV - Power Supply/Chargers
- (1) LINQ2 - Network Communications Module
- (2) ACM8 - Fused Access Power Controllers
- (1) PD16W - Power Distribution Module

##### T2MK77F16V

Fully assembled kit includes:

- Trove2 enclosure with TM2 Altronix/Mercury backplane and TMV2 door backplane
- (2) eFlow104NBV - Power Supply/Chargers
- (2) ACM8 - Fused Access Power Controllers
- (1) VR6 - Voltage Regulator
- (1) PDS8 - Dual Input Power Distribution Module

##### T2MK77F16QV

Fully assembled kit includes:

- Trove2 enclosure with TM2 Altronix/Mercury backplane and TMV2 door backplane
- (2) eFlow104NBV - Power Supply/Chargers
- (1) LINQ2 - Network Communications Module
- (2) ACM8 - Fused Access Power Controllers
- (1) VR6 - Voltage Regulator
- (1) PDS8 - Dual Input Power Distribution Module

Please refer to the included corresponding Sub-Assembly Installation Guides for further information.

## Installation Guide

All registered trademarks are property of their respective owners.

Rev. TMKV030320

Installing Company: \_\_\_\_\_ Service Rep. Name: \_\_\_\_\_

Address: \_\_\_\_\_ Phone #: \_\_\_\_\_



More than just power.™

## Overview:

Altronix Trove Mercury kits are pre-assembled and consist of Trove2M2 enclosure/backplane with factory installed Altronix power supply/charger(s) and sub-assemblies. These kits also accommodate various combinations of Mercury boards for up to sixteen (16) doors in a single enclosure.

## Configuration Chart:

Altronix Model Number	Networkable	220VAC 60Hz Input Current (A)	Power Supply Board Input Fuse Rating	Power Supply Board Battery Fuse Rating	Nominal DC Output Voltage				Maximum Supply Current for Main and Aux. Outputs on Power Supply board and ACM4/ACM8 Access Power Controller's outputs	Fail-Safe/Fail-Secure or Dry Form "C" Outputs	Current Per ACM4/ACM8 Output (A)	ACM4/ACM8 Board Input Fuse Rating	ACM4/ACM8 Board Output Fuse Rating	PDS8 Board Input Fuse Rating	PDS8 Board Output Fuse Rating	PD16W Board Output Fuse Rating
					Power Supply 1		Power Supply 2									
					[DC]	[Aux]	[DC]	[Aux]								
					Output Range (VDC)	Output Range (VDC)	Output Range (VDC)	Output Range (VDC)								
T2MK3F4V	-	2.5	5A/250V	10A/32V	20.19-26.4	20.19-26.4	-	-	24VDC @ 5.8A	4	2.5	10A/32V	3A/32V	10A/32V	3A/32V	-
T2MK3F4QV	✓	2.5	5A/250V	10A/32V	20.19-26.4	20.19-26.4	-	-	24VDC @ 5.8A	4	2.5	10A/32V	3A/32V	10A/32V	3A/32V	-
T2MK3F8V	-	2.5	5A/250V	10A/32V	20.19-26.4	20.19-26.4	-	-	24VDC @ 5.8A	8	2.5	10A/250V	3.5A/250V	10A/32V	3A/32V	-
T2MK3F8QV	✓	2.5	5A/250V	10A/32V	20.19-26.4	20.19-26.4	-	-	24VDC @ 5.8A	8	2.5	10A/250V	3.5A/250V	10A/32V	3A/32V	-
T2MK7F8V	-	2.7	6.3A/250V	15A/32V	20.17-26.4	20.28-26.4	-	-	24VDC @ 9.2A	8	2.5	10A/250V	3.5A/250V	10A/32V	3A/32V	-
T2MK7F8QV	✓	2.7	6.3A/250V	15A/32V	20.17-26.4	20.28-26.4	-	-	24VDC @ 9.2A	8	2.5	10A/250V	3.5A/250V	10A/32V	3A/32V	-
T2MK75F16V	-	4.8	6.3A/250V 5A/250V	15A/32V	20.17-26.4	20.28-26.4	9.7-13.2	10.03-13.2	12VDC @ 9.3A 24VDC @ 9.2A	16	2.5	10A/250V	3.5A/250V	-	-	3.5A/250V
T2MK75F16QV	✓	4.8	6.3A/250V 5A/250V	15A/32V	20.17-26.4	20.28-26.4	9.7-13.2	10.03-13.2	12VDC @ 9.3A 24VDC @ 9.2A	16	2.5	10A/250V	3.5A/250V	-	-	3.5A/250V
T2MK77F16V	-	5.4	6.3A/250V	15A/32V	20.17-26.4	20.28-26.4	20.17-26.4	20.28-26.4	24VDC @ 9.2A	16	2.5	10A/250V	3.5A/250V	10A/32V	3A/32V	-
T2MK77F16QV	✓	5.4	6.3A/250V	15A/32V	20.17-26.4	20.28-26.4	20.17-26.4	20.28-26.4	24VDC @ 9.2A	16	2.5	10A/250V	3.5A/250V	10A/32V	3A/32V	-

## Installation Instructions:

Wiring methods shall be in accordance with the National Electrical Code/NFPA 70/ANSI, and with all local codes and authorities having jurisdiction. Product is intended for indoor use only.

1. Remove backplane(s) from enclosure. Do not discard hardware.
2. Mark and predrill holes in the wall to line up with the top three keyholes in the enclosure. Install three upper fasteners and screws in the wall with the screw heads protruding. Place the enclosure's upper keyholes over the three upper screws, level and secure. Mark the position of the lower three holes. Remove the enclosure. Drill the lower holes and install the three fasteners. Place the enclosure's upper keyholes over the three upper screws. Install the three lower screws and make sure to tighten all screws.
3. Mount included UL Listed tamper switch (Altronix Model TS112 or equivalent) in desired location, opposite hinge. Slide the tamper switch bracket onto the edge of the enclosure approximately 2" from the right side (Fig. 1, pg. 2). Connect tamper switch wiring to the Access Control Panel input or the appropriate UL Listed reporting device. To activate alarm signal open the door of the enclosure.
4. Refer to the *eFlow Power Supply/Charger Installation Guide* for eFlow6NBV, eFlow102NBV, eFlow104NBV and *Sub-Assembly Installation Guide* for the following models: ACM4, ACM8, LINQ2, PDS8, PD16W, VR6 for further installation instructions.
5. Fasten snap on spacers onto metal pems configuration of backplane depending on the Mercury access controller (Fig. 2-5, pg. 3-6).
6. Position Mercury access controller module over corresponding spacers and depress onto snap on spacers (Fig. 2-5, pg. 3-6).
7. Mount backplane to enclosure with hardware.

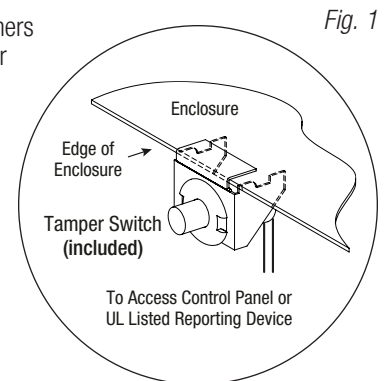

Fig. 1

## T2MK3F4V, T2MK3F4QV, T2MK3F8V, T2MK3F8QV: Configuration of Mercury Boards:

1. Fasten snap on spacers onto metal pems configuration (A), (B), (C) or (D) of backplane depending on the access controller (Fig. 2, pg. 3).
2. Position access controller module over corresponding spacers and depress onto snap on spacers (Fig. 2a, pg. 3).
3. Mount backplane to enclosure with hardware.

### Access Controller Position Chart for the Following Models:

Mercury Access Controller	Pem Mounting
EP1502, MR52, MR16IN, MR16OUT	(A)
EP2500, MUX8	(B)
EP1501, MR51e	(C)
MR50	(D)

Fig. 2

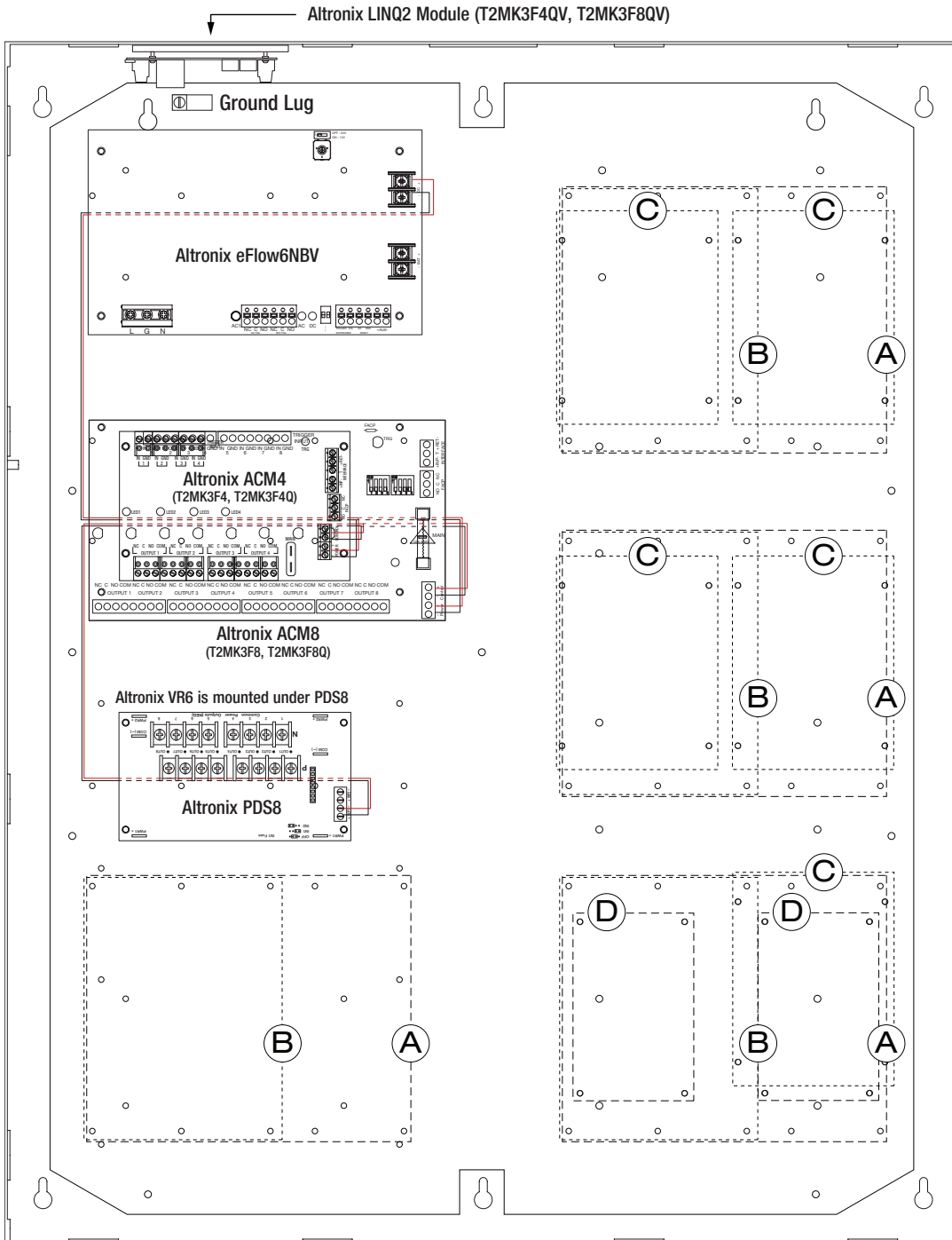
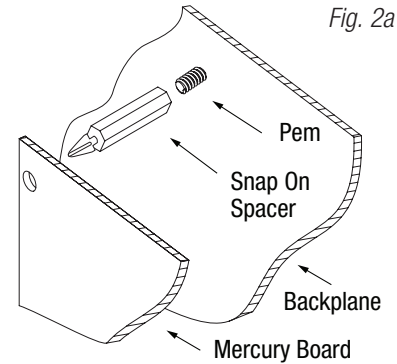

Fig. 2a



## T2MK7F8V, T2MK7F8QV: Configuration of Mercury Boards:

1. Fasten snap on spacers onto metal pems configuration (A), (B), (C) or (D) of backplane depending on the access controller (Fig. 3, pg. 4).
2. Position access controller module over corresponding spacers and depress onto snap on spacers (Fig. 3a, pg. 4).
3. Mount backplane to enclosure with hardware.

### Access Controller Position Chart for the Following Models:

Mercury Access Controller	Pem Mounting
EP1502, MR52, MR16IN, MR16OUT	(A)
EP2500, MUX8	(B)
EP1501, MR51e	(C)
MR50	(D)

Fig. 3

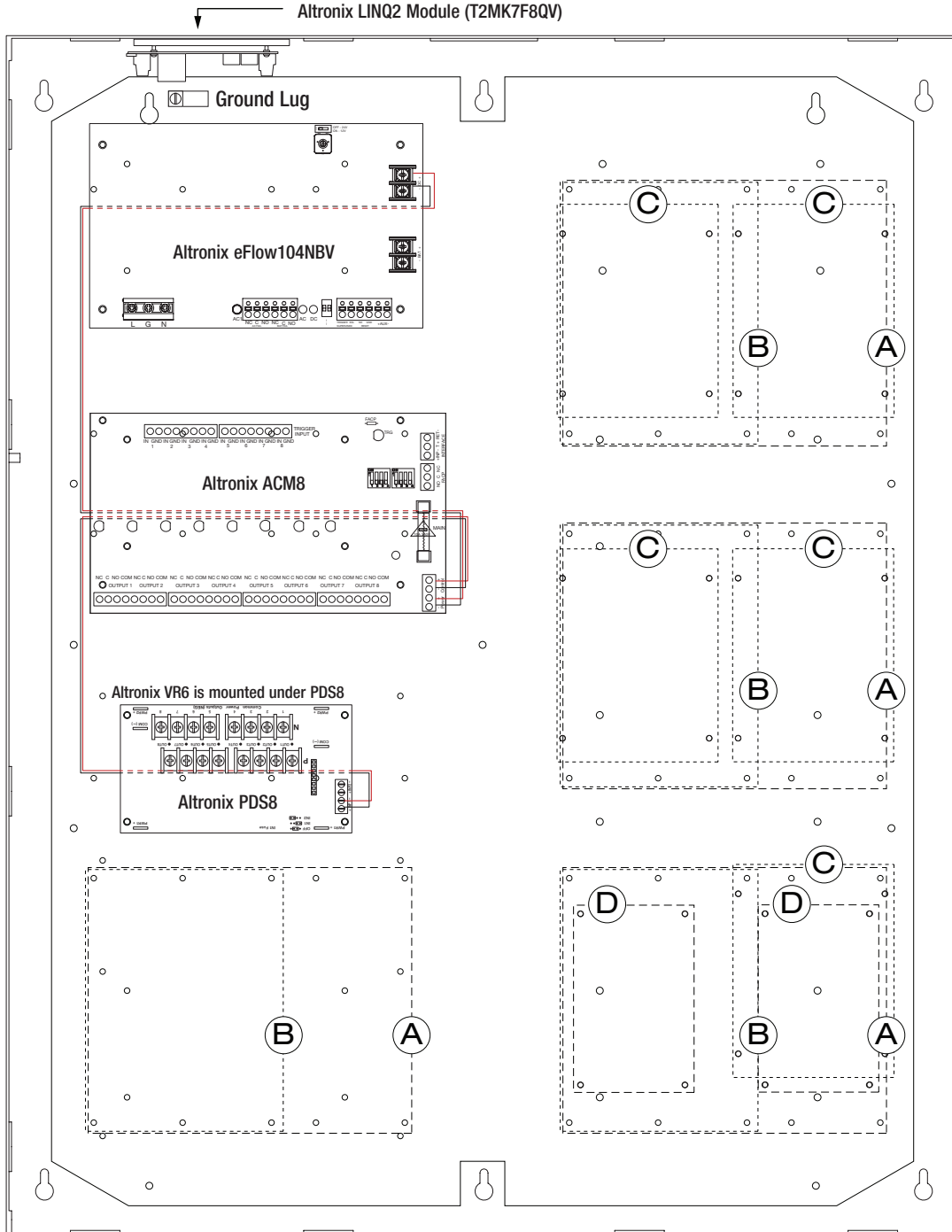
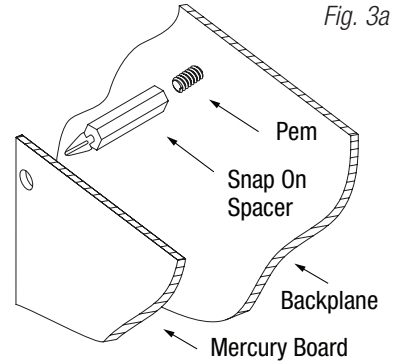

Fig. 3a



## T2MK75F16V, T2MK75F16QV: Configuration of Mercury Boards:

1. Fasten snap on spacers onto metal pems configuration (A), (B), (C) or (D) of backplane depending on the access controller (Fig. 4, pg. 5).
2. Position access controller module over corresponding spacers and depress onto snap on spacers (Fig. 4a, pg. 5).
3. Mount backplane to enclosure with hardware.

### Access Controller Position Chart for the Following Models:

Mercury Access Controller	Pem Mounting
EP1502, MR52, MR16IN, MR16OUT	(A)
EP2500, MUX8	(B)
EP1501, MR51e	(C)
MR50	(D)

Fig. 4

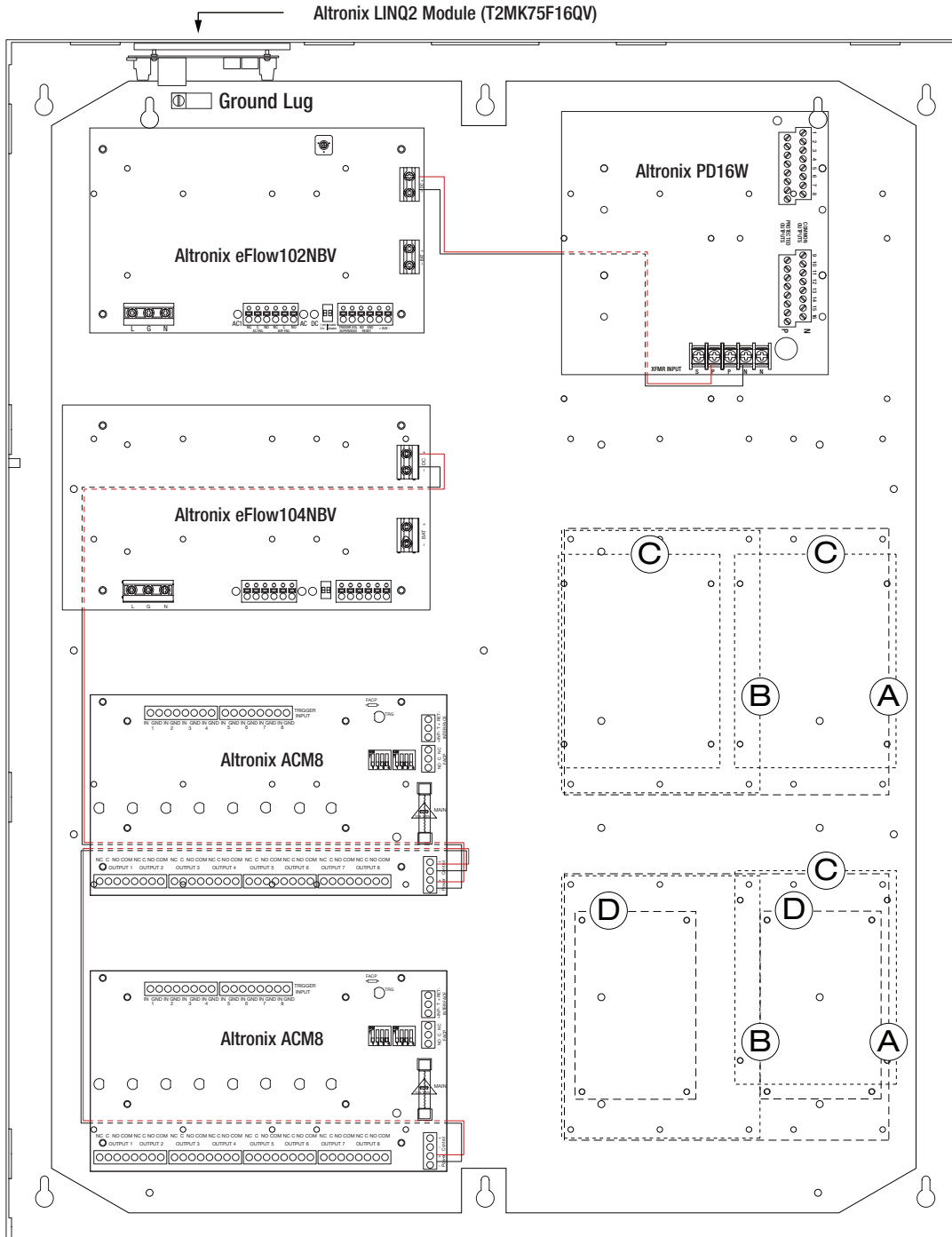
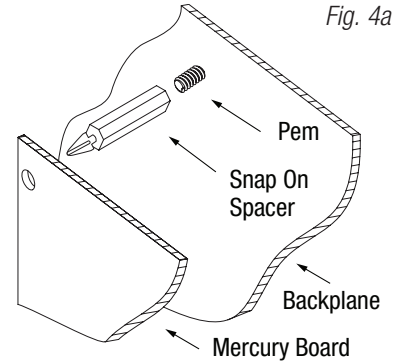

Fig. 4a



## T2MK77F16V, T2MK77F16QV: Configuration of Mercury Boards:

1. Fasten snap on spacers onto metal pems configuration (A), (B), (C) or (D) of backplane depending on the access controller (Fig. 5, pg. 6).
2. Position access controller module over corresponding spacers and depress onto snap on spacers (Fig. 5a, pg. 6).
3. Mount backplane to enclosure with hardware.

### Access Controller Position Chart for the Following Models:

Mercury Access Controller	Pem Mounting
EP1502, MR52, MR16IN, MR16OUT	(A)
EP2500, MUX8	(B)
EP1501, MR51e	(C)
MR50	(D)

Fig. 5

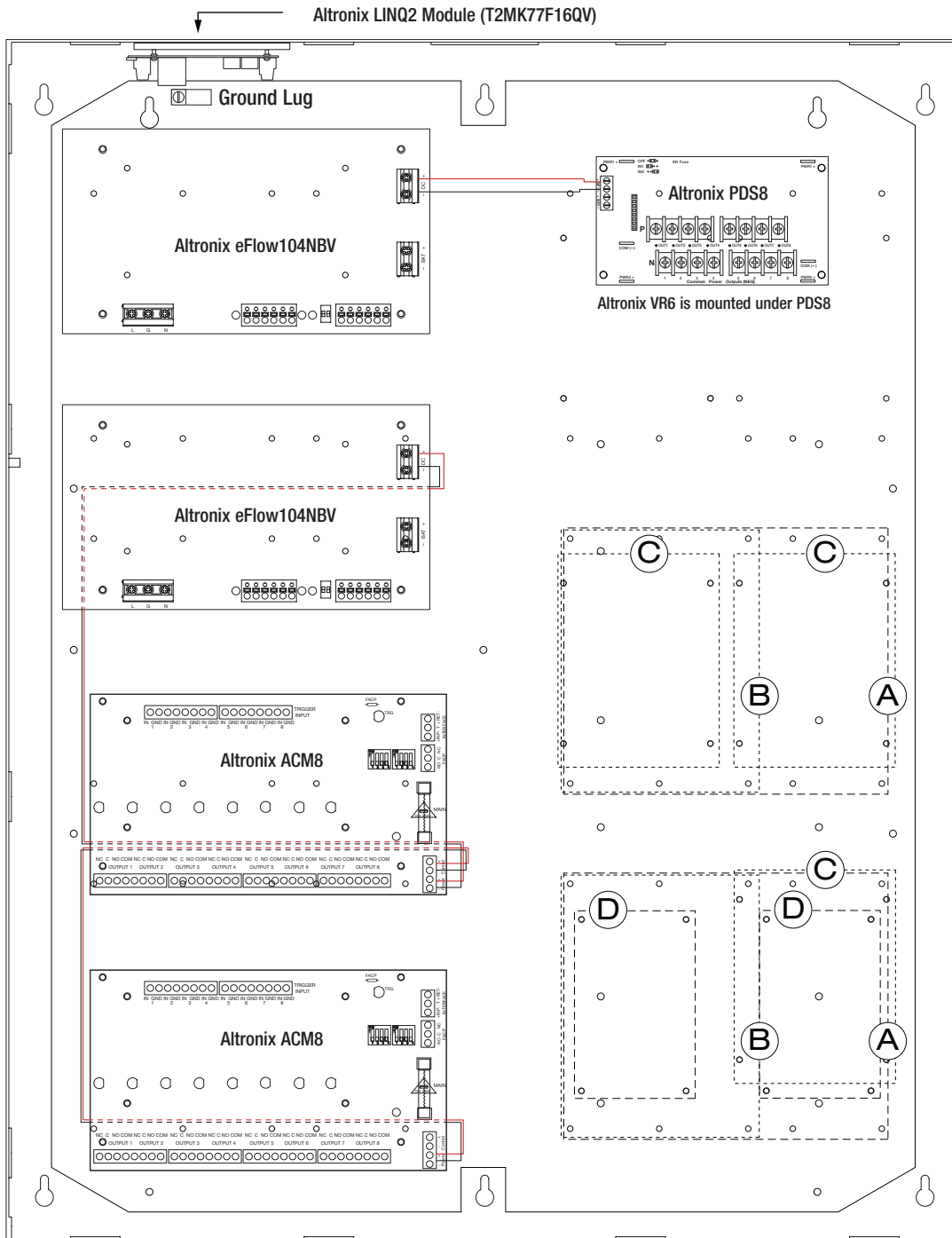
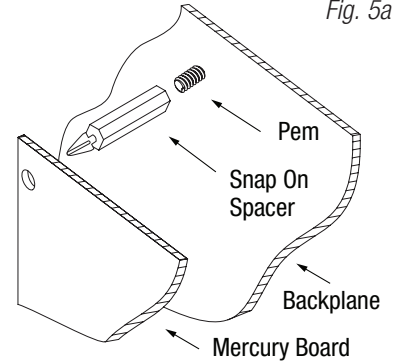

Fig. 5a



# TMV2 (T2MK75F16V, T2MK75F16QV, T2MK77F16V, and T2MK77F16QV):

TMV2 accommodates a variety of Mercury boards with or without Altronix sub-assemblies for access systems.

## Configuration of Mercury and/or Altronix Boards

### Mercury Access Controllers:

1. Fasten spacers onto metal pems configuration (A) (B) of backplane depending on the access controller (Fig. 6, pg. 7).
2. Position access controller module over corresponding spacers and depress onto snap on spacers (Fig. 6a, pg. 7).
3. Mount backplane to enclosure with hardware.

### Altronix Sub-Assemblies and/or Adapters:

1. Fasten spacers to pems which match the hole pattern (C) for Altronix Sub-Assemblies (Fig. 6, 6a, pg. 7).
2. Mount boards to spacers utilizing pan head screws provided with the product (Fig. 6, pg. 7).

### Access Controller Position Chart for the Following Models:

Mercury	
Access Controller	Pem Mounting
EP1502, MR52, MR16IN, MR16OUT	(A)
EP2500, MUX8	(B)
Altronix	
Sub-Assembly or Adapter	Pem Mounting
ACM4(CB), MOM5, PD4UL(CB), PD8UL(CB), PDS8(CB), VR6, GB1 (Genetec Synergis Cloud Link adapter plate)	(C)

Fig. 6

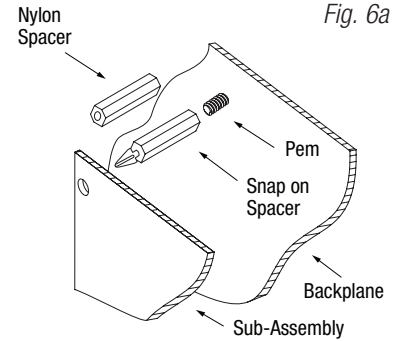
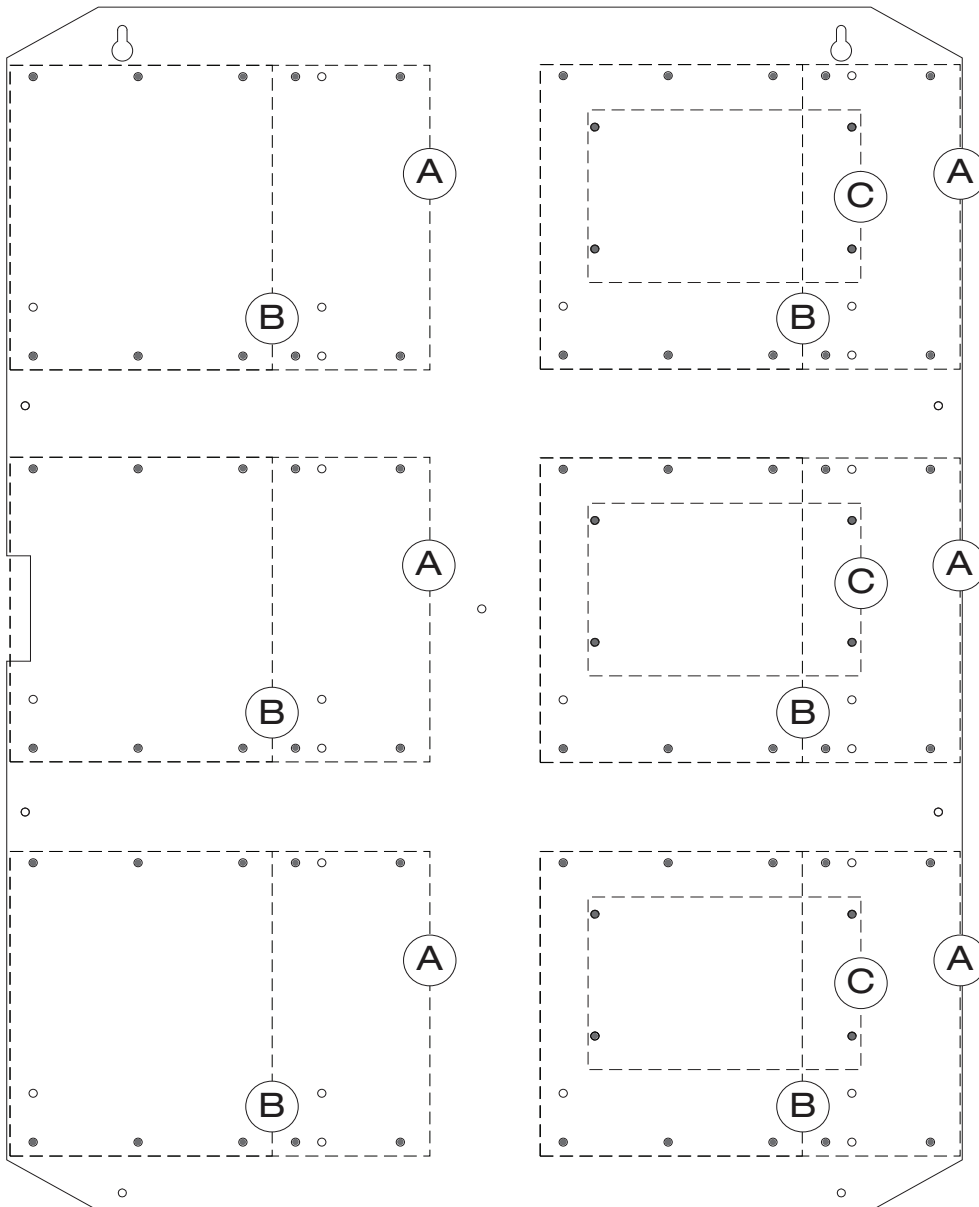

## Enclosure Dimensions (H x W x D approximate):

27.25" x 21.5" x 6.5" (692.2mm x 552.5mm x 165.1mm)

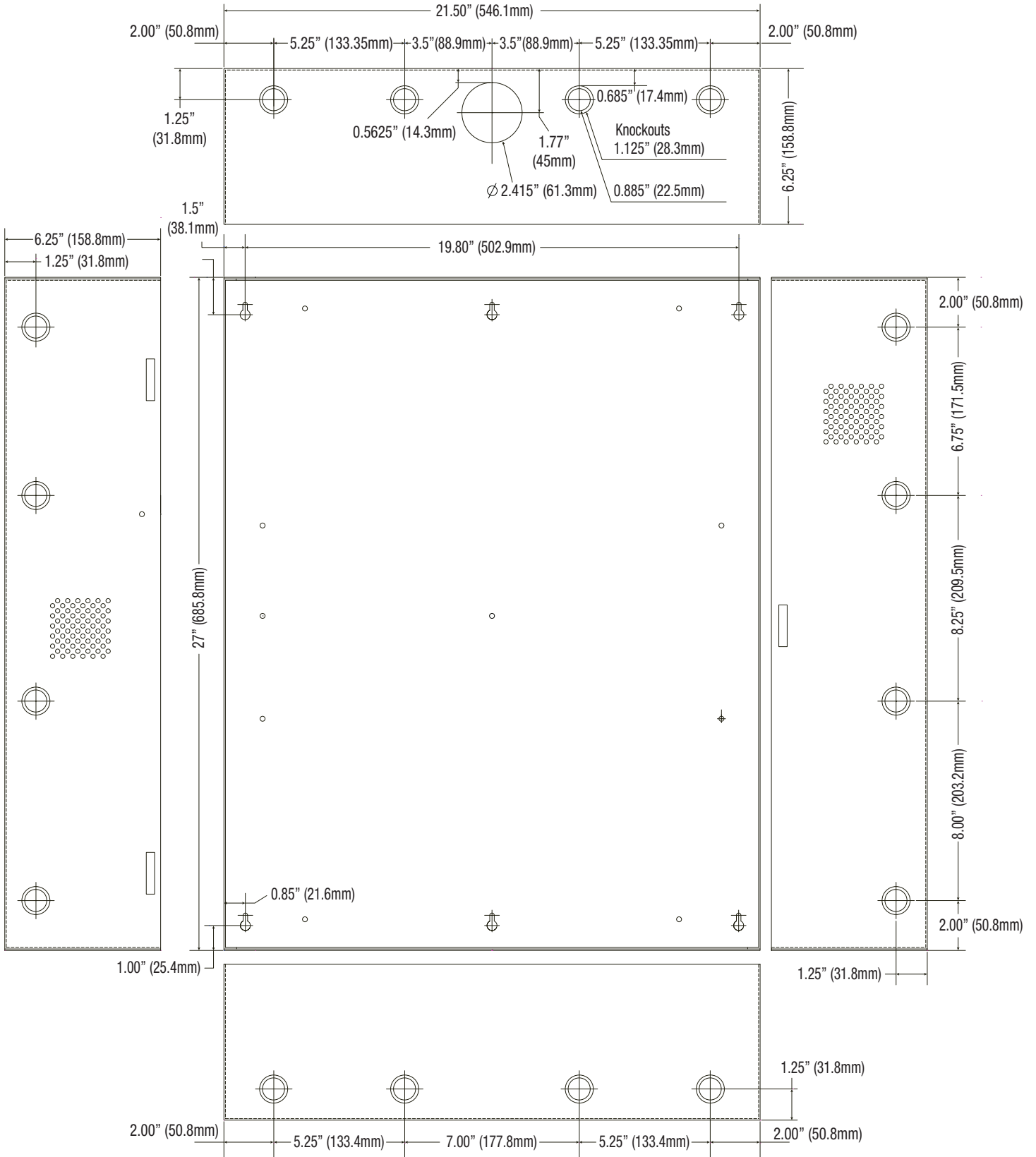

Altronix is not responsible for any typographical errors.

140 58th Street, Brooklyn, New York 11220 USA | phone: 718-567-8181 | fax: 718-567-9056  
 web site: [www.altronix.com](http://www.altronix.com) | e-mail: [info@altronix.com](mailto:info@altronix.com) | Lifetime Warranty  
 IITrove2/Mercury Fused V Kits

E16W

