



TempoA4

Occupancy Alert System



Overview:

Altronix TempoA4 is designed to alert management when unauthorized loitering occurs in up to four (4) secure rooms. TempoA4 has built-in LINQ Technology to remotely monitor and control the unit.

Specifications:

Input Power Options:

- 115VAC, 60Hz, 1A (with line cord and transformer)
- Trigger
 - Four (4) Door Sensor/Trigger inputs.
 - Four (4) Strobe "Steady" Trigger Inputs.
 - Four (4) Strobe "Flash" Trigger Inputs.
 - Four (4) "Panic/Emergency" Trigger Inputs.

Output Options:

- 12VDC/2.5A, 24VDC/1.25A (30W).
- Four (4) Strobe Switched Power Outputs.
- Eight (8) Aux. Power Outputs.

Timer:

- Alphanumeric LCD display simplifies programming.
- EE Prom memory protects against loss of programming due to power failure.
- Momentary and/or Latching Events.

Battery Backup:

- Sealed lead acid or gel type.
- Failover - Upon AC loss, instantaneous.

LINQ Technology:

- Remote network management allows for device reset and monitoring.
- Provides local and/or remote access to critical information via LAN/WAN.
- Event log tracks history.

Visual Indicators:

- AC Power (Green) - Input voltage is present.
- DC Output (Green) - 12VDC
- DC Output (Orange) - 24VDC
- Trigger - Active.

Physical and Environmental:

- Enclosure Dimensions (H x W x D approx.):
13.5" x 13" x 3.25"
(342.9mm x 330.2mm x 82.6mm).
 - 1/2" and 3/4" combination knockouts.
 - Enclosure accommodates up to two (2) 12VDC/7AH batteries.
- Temperature:
 - Operating: 0°C to 49°C (32°F to 120°F).
 - Storage: - 20°C to 70°C (- 4°F to 158°F).
- Relative Humidity: 85% +/- 5%.

Installation Instructions:

Wiring methods shall be in accordance with the National Electrical Code/NFPA 70/NFPA 72/ANSI, and with all local codes and authorities having jurisdiction. Product is intended for indoor use only.

1. Mount the unit in the desired location. Mark and predrill holes in the wall to line up with the top two keyholes in the enclosure. Install two upper fasteners and screws in the wall with the screw heads protruding. Place the enclosure's upper keyholes over the two upper screws; level and secure. Mark the position of the lower two holes. Remove the enclosure. Drill the lower holes and install two fasteners. Place the enclosure's upper keyholes over the two upper screws. Install the two lower screws and make sure to tighten all screws (*Enclosure Dimensions, pg. 4*). Secure enclosure to earth ground (*Fig 1, pg. 2*).
2. Connect the Brown wire from the strobe to TempoA2B terminals marked [DOOR 1 LED +].
3. Connect the Green wire from the strobe trigger to TempoA2B terminals marked [DOOR 1 Strobe Steady]. Connect the Yellow wire from the strobe trigger to TempoA2B terminals marked [DOOR 2 Strobe Steady].
4. Connect the positive and negative terminals on the Optical Latch Sensor for Door 1 to the TempoA2B terminals marked [- AUX1 +]. Connect the White and Blue wires from the Optical Latch Sensor to the TempoA2B terminals marked [DOOR 1 C, TRIG, NO].
5. Connect the positive and negative terminals on the Optical Latch Sensor for Door 2 to the TempoA2B terminals marked [- AUX2 +]. Connect the White and Blue wires from the Optical Latch Sensor to the TempoA2B terminals marked [DOOR 2 C, TRIG, NO].
6. Plug in 3-wire line cord. Keep power-limited wiring separate from non-power-limited wiring. Minimum 0.25" spacing must be provided. Use separate knockouts.

Programming:

Option 1: Network programming.

1. Connect the structured cable to the network port on the TempoA2B.
2. Open a browser and input the IP address 192.168.168.168. the login screen will open enter the user name and password (user: admin password; admin)
3. The setup window will open. Program the trigger delay times for each door. Click on the pencil under DOOR1, Timer1 enter the Minutes and Seconds for the initial time sequence for when the door is latched. The LED will come on steady when time limit has been reached.
4. Click on the pencil under DOOR1, Timer2 enter the Minutes and Seconds for the second time sequence after Timer1 has expired. The LED will flash when the second time limit has been reached.
When a second door is connected follow steps 3 & 4 for DOOR 2.

Option 2: Programming timer via TempoA2B Push buttons.

1. Using the UP & Down push buttons on the TempoA2B, select the door to be programmed, then push the enter button.
2. Using the UP & Down button select Timer 1. Using the UP button scroll up until the desired delay time is reached. Then hit the enter button. The LED will come on steady when time limit has been reached.
3. Using the UP & Down button select Timer 2. Using the UP button scroll up until the desired delay time is reached. Then hit the enter button. The LED will flash when the second time limit has been reached.

Note: When a second door is connected follow steps 2 & 3 for DOOR 2.

Terminal Identification:

Terminal/Legend	Description
(A) RJ45	Network / LINQ Connection
(B) Strobe 2	Power Outputs. Steady and Flash.
(C) Trig Panic	Door 2 - Sensor/Trigger input and Panic Input Trigger.
(D) Strobe 1	Power Outputs. Steady and Flash.
(E) Trig Panic	Door 1 - Sensor/Trigger input and Panic Input Trigger.
(F) Aux 1 to 4	DC Aux outputs 1 to 4.
(G) + BAT -	Stand-by battery connections.
(H) Input	Low voltage AC input.

Fig. 1

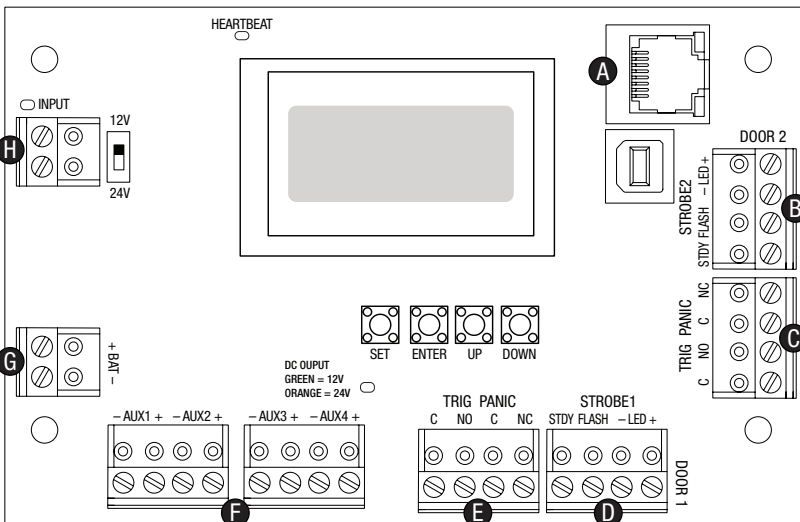



The lightning flash with arrowhead symbol within an equilateral triangle is intended to alert the user to the presence of an insulated DANGEROUS VOLTAGE within the product's enclosure that may be of sufficient magnitude to constitute an electric shock.



The exclamation point within an equilateral triangle is intended to alert the user to the presence of important operating and maintenance (servicing) instructions in the literature accompanying the appliance.



CAUTION
RISK OF ELECTRIC SHOCK
DO NOT OPEN



CAUTION: To reduce the risk of electric shock do not open enclosure. There are no user serviceable parts inside. Refer servicing to qualified service personnel.

Maintenance:

Unit should be tested at least once a year for the proper operation as follows:

Output Voltage Test: Under normal load conditions the DC output voltage should be checked for proper voltage level (*Stand-by Specifications Chart*).

Battery Test: Under normal load conditions check that the battery is fully charged, check specified voltage both at the battery terminal and at the board terminals marked [- BAT +] to ensure that there is no break in the battery connection wires.

Note: Maximum charging current under discharge is 500mA.

Note: Expected battery life is 5 years; however, it is recommended changing batteries in 4 years or less if needed.

Fig. 2

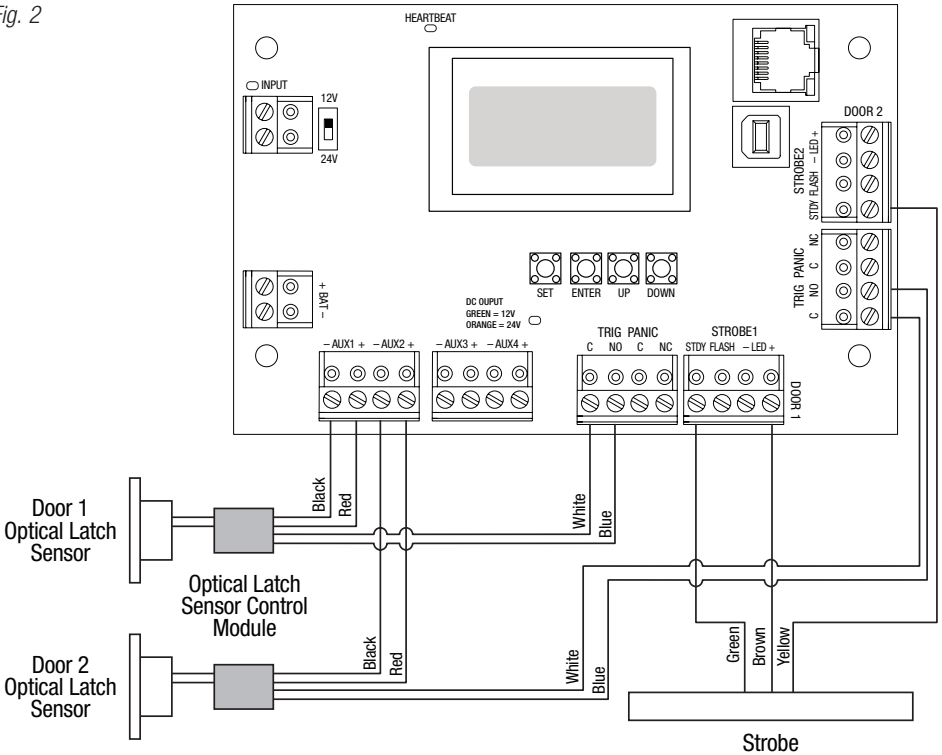

Enclosure Dimensions (BC300):

13.5" x 13" x 3.25" (342.9mm x 330.2mm x 82.6mm)

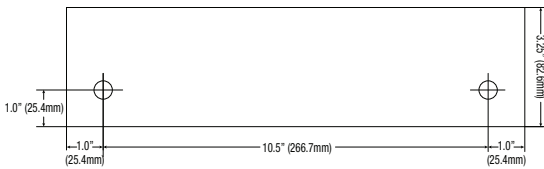
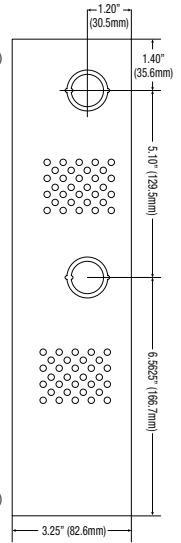
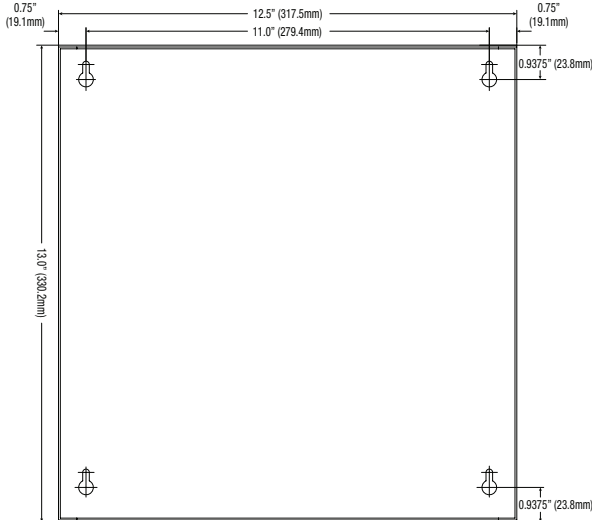
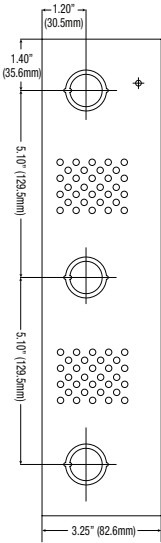
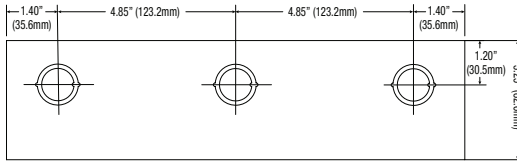

Altronix is not responsible for any typographical errors.

140 58th Street, Brooklyn, New York 11220 USA | phone: 718-567-8181 | fax: 718-567-9056
 website: www.altronix.com | e-mail: info@altronix.com | Lifetime Warranty
 IITempoA4 Rev. 022024 B20X

