

Model No.

USAC-110



Rackmount Utility Shelf + Power Strip

Panel Space:	1U or 1.72" [44]
Overall Depth:	10.75" [273]
Overall Width:	19.00" [483]
Usable Width:	17.56" [446]
Load Capacity:	50 lbs. [22.6 kg]



BUNDLE INCLUDES UTILITY SHELF AND AC POWER STRIP. The shelf is solid steel with rear notches to mount the included power strip and tie-off points for cable management. Both products are made in the U.S.A. using U.S. steel, the power strip uses global components.

SHELF

CONSTRUCTION: Single piece 16-gauge U.S. steel

FINISH: Smooth black powder epoxy finish

BASE: Solid with tie-off points in rear for cable management

FRONT: 0.375" flange adds strength and helps equipment remain in place.

REAR: 0.56" slotted flange features tie-off points for cables, plus notches to quickly mount the 12" power strip.

COMPLIANCE: E.I.A./T.I.A.

ORIGIN: Made in the U.S.A.

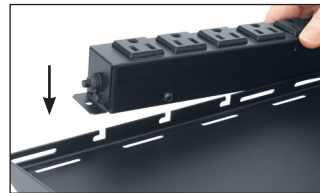

Notches on the shelf's rear flange make it easy to mount the 12" power strip.

POWER STRIP

CHASSIS: 12" x 1.5" x 1.625"

POWER OUTLETS: Seven (7) NEMA 5-15R receptacles

POWER RATING: 120VAC 15A 60Hz

CORD: Detachable 6 ft. IEC power cord with NEMA 5-15P molded plug

NRTL: ETL Listed

ORIGIN: Made in the U.S.A. with global components



NOTE: To purchase separately, order shelf US-110 and power strip ACS-1507.

A&E SPECIFICATIONS

The rackmount shelf/power strip bundle shall be Lowell model USAC-110, which shall include a 1U x 10.75"D x 19"W certified U.S. steel shelf with solid base, smooth black powder epoxy finish, front/rear flanges, tie-off points for cables, and notches to mount the included power strip. The shelf shall have a load capacity of 50 lbs. The (12"L) ETL Listed power strip shall feature seven (7) 15A NEMA receptacles, circuit breaker, and detachable 6 ft. IEC cord with molded plug. It shall have a power rating of 120VAC 15A 60Hz. The shelf and power strip shall be made in the U.S.A.

TECHNICAL DRAWINGS

Dimensions are inches and [mm] unless stated otherwise.

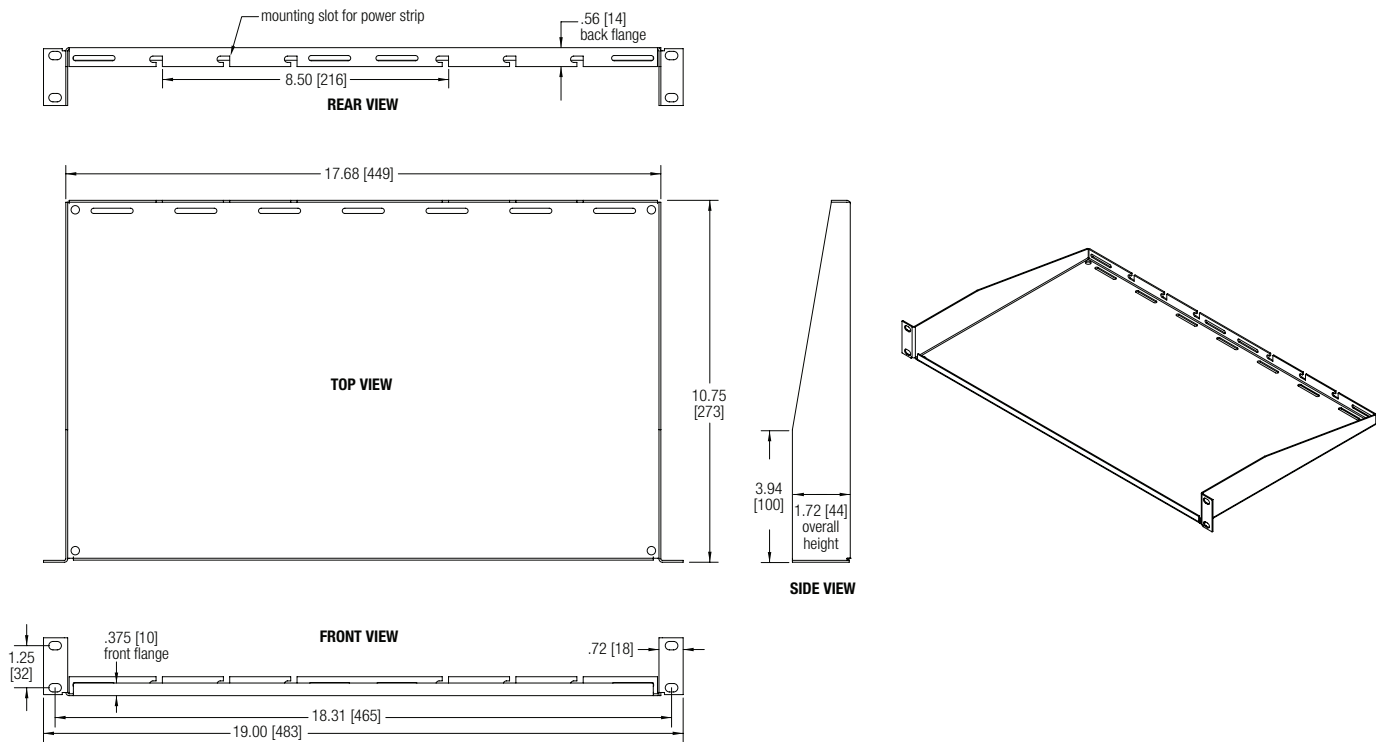

USAC SERIES (shelf + power strip bundle)

THIS SPEC

Model No.	Panel Space	Overall Depth	Overall Height	Overall Width	Useable Width	Load Capacity	Power Strip
USAC-110	1U	10.75 [273]	1.72 [44]	19.00 [483]	17.56 [446]	50 lbs. [22.6 kg]	7 (15A) outlets
USAC-210	2U	10.75 [273]	3.47 [88]	19.00 [483]	17.56 [446]	50 lbs. [22.6 kg]	7 (15A) outlets
USAC-114	1U	14.00 [356]	1.72 [44]	19.00 [483]	17.56 [446]	50 lbs. [22.6 kg]	7 (15A) outlets
USAC-214	2U	14.00 [356]	3.47 [88]	19.00 [483]	17.56 [446]	50 lbs. [22.6 kg]	7 (15A) outlets

Dimensions = inches [mm]; 1U = 1.75"