



INSTALLATION GUIDE

APTZ-3045-07 & APTZ-3045-04

Class I Groups B, C, & D T6 Tamb +50°C (+122°F)
NEMA TYPE 4
Class I Zone 1 Group IIB H2

READ THIS FIRST

10/03/2016
IVC Drawing # IVC1748
Rev 1.0.1

REVISION HISTORY:

1.0.0	10/3/2016	Initial Draft
1.0.1	9/11/2018	Updated camera cable gland, revised notes. Added APTZ-3045-04 with Z-1203 slip ring.

©2018, Industrial Video & Control Co. The Industrial Video & Control Co. logo is a registered trademark of Industrial Video & Control Co.. All other company names and products are trademarks or registered trademarks of their respective companies. All information provided is subject to change without notice.

1

Check Receipt of All Components

1.1 Component List

Camera with lens including:

- PTZ camera
- Any special mounting equipment (e.g. IVC mount arm)



APTZ-3045-07 shown with sunshield and wiper

NOTE: Only one test cable is enclosed per order, it may be in a different box

1.2 Additional Installation Requirements

The following items are required to properly complete installation:

- 12 x 1/4" base fasteners to suit your installation
- PTZ controlling device
- A flathead screw driver
- Tools for special mounting kit
- Window cleaner

2

Set Up and Bench Test For Camera APTZ-3045-07

2.1 Remove Packaging and Inspect Camera

To ensure the integrity of the camera during shipping certain packing materials are placed around the PTZ camera. Remove the PTZ camera carefully.

If any damage occurred during shipping please call our support line (617-467-3059) for assistance.

2.2 Connect Camera

This unit can be powered using 115 or 230 VAC.

NOTE: Network and power connectivity is provided on two separate 15 foot cables. Do not attempt to remove these cables or alter their installation in any way. The cables are a controlled element of the certification and are potted in place.

The camera is provided with two factory installed cables. One is a weatherproof 3-conductor power cable and the other is a weatherproof CAT5e cable that is terminated with an RJ-45 connector.

NOTE: The RJ-45 connector is not weatherproof, so it should be terminated in a manner that ensures the weatherproof integrity of the network cable.

Connect the power wires to an appropriate power source. Plug the network cable into a switch or other network appliance necessary to connect the camera to your network. **NOTE:** A junction box containing an Ethernet extender may have been included with the camera. Consult Appendix B for details on this box.

Wire Table		
Function	Color	Type
115 or 230 VAC Line	Black	Straight
115 or 230 VAC Neutral	White	Straight
115 or 230 VAC Ground	Green	Straight
Network	Black	RJ-45

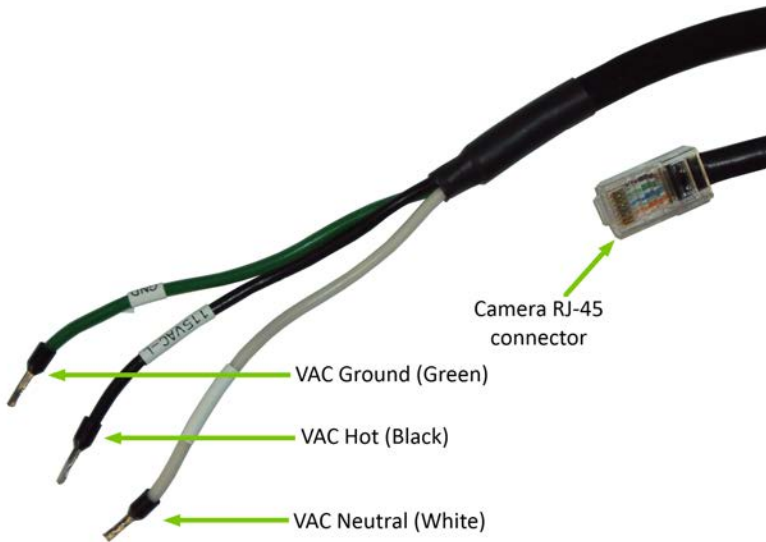

2.3 Set IP Address

For your convenience, the camera's default IP is printed on the information label attached to the camera and its shipping container.

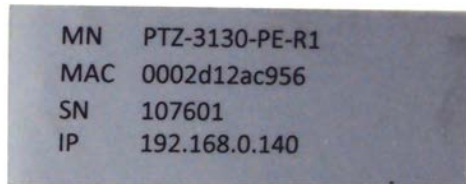

Example camera information label

The camera's IP address has been set on a 192.168.0.x/ class network. For this section, the computer you are using for bench testing must be set to the same subnet as the camera (e.g. 192.168.0.###). Consult your network administrator if you need assistance.

Once you have located the IP address please follow the instructions below to set it to a permanent address:

1. Using a web browser enter the IP address of the camera in the address bar.
2. When prompted by your browser, enter the camera username (factory default = **system**) and password (factory default = **system**). If prompted to load any plugins, do so.

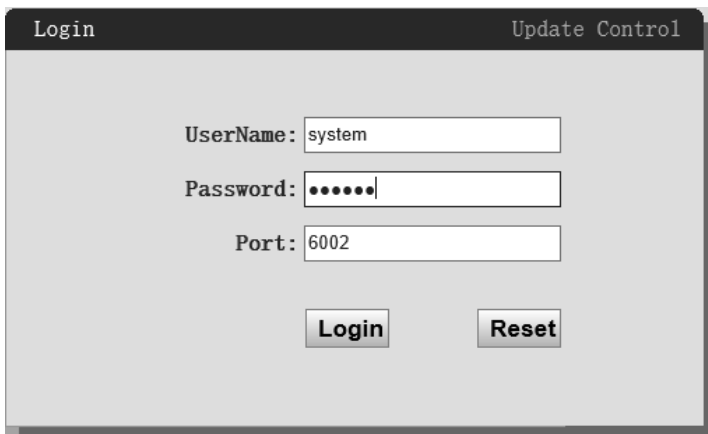
A screenshot of a web browser window showing a login page. The window title is "Login" and "Update Control" is visible in the top right corner. The page has a light gray background. There are three input fields: "UserName:" with the text "system", "Password:" with seven dots, and "Port:" with the text "6002". Below the input fields are two buttons: "Login" and "Reset".

3. To change the IP address click the Configuration [link](#) on the top right of the camera's web page.



- Click on the **Network** button in the menu on the resulting page. In the expanded menu, click on **TCP/IP**.

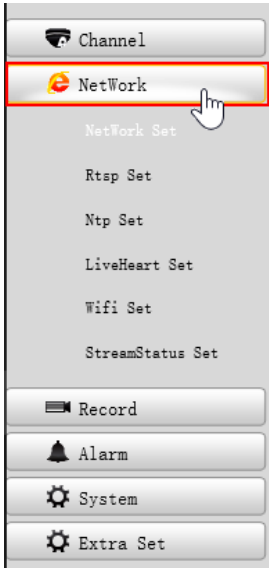

- On the resulting page, enter the new IP address, Subnet Mask, and Default Gateway. Click the **Submit** button at the bottom of the page when satisfied with the camera's network settings.

General Settings

Fixed IP Address Enable DHCP

IP Address:	192.168.1.101
Subnet Mask:	255.255.255.0
GateWay:	192.168.1.1
DNS:	192.168.1.1
Alternate DNS:	192.168.1.1

- Enter the new IP address in the address bar of your browser and observe live video on the **Live View** page.

2.4 Configure Camera Login Credentials

IVC camera management software uses the **system** login to access the camera. If you desire to change the system password, follow the steps below:

1. If not already logged in, log into the camera by typing the camera's IP address into a browser address bar.
2. When prompted by your browser, enter the default username (**system**) and password (**system**).
3. Click on the **Configuration** link.
4. Click the **System** button.
5. Click on **System** in the resulting page's menu. Then click **Account** in the expanded menu.

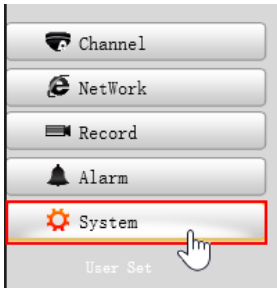

6. On the resulting page, click on the **Modify** icon for the admin account.

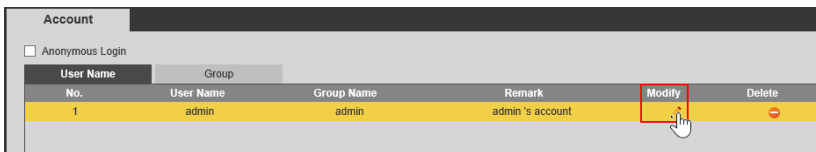

7. On the resulting page, click the **Change Password** button.

User Set

User List	Permissions
system	<input checked="" type="checkbox"/> Control PTZ <input checked="" type="checkbox"/> Start or stop recording <input checked="" type="checkbox"/> Remote configuration <input checked="" type="checkbox"/> Remote query state and logs <input checked="" type="checkbox"/> Remote maintenance (Upgrade, Reboot, Restore) <input checked="" type="checkbox"/> Using two-way audio <input checked="" type="checkbox"/> Remote viewing live video <input checked="" type="checkbox"/> Manage user <input checked="" type="checkbox"/> Change the password <input checked="" type="checkbox"/> Remote playback <input checked="" type="checkbox"/> Remote Alarm Upload <input checked="" type="checkbox"/> Remote Control Port <input checked="" type="checkbox"/> Remote Connection RTSP

8. Then enter the current password in the **Old Password** field, the new password in the **New Password** and **Confirm Password** fields.
NOTE: The new login credentials will be needed to configure the camera in your IVC camera management software.

User Set

UserName:

Old password:

New password:

Confirm password:

9. Click the **Submit** button When satisfied with these settings.
10.Refresh the web page and enter the new credentials when prompted. Observe proper camera operation.

2.5 Verify Video

1. Connect the camera Ethernet cable to computer or network.
2. Power the camera.
3. Ensure proper initialization sequence for pan clockwise, pan counter-clockwise, tilt up, tilt down, zoom wide and zoom tele.

4. Type in IP address of camera in browser window.
5. Ensure clear video and proper camera operation.
6. Check wiper operation.

2.6 Bench Test Completed

This concludes the bench test.

3

Set Up and Bench Test for Camera APTZ-3045-04

3.1 Remove Packaging and Inspect Camera

To ensure the integrity of the camera during shipping certain packing materials are placed around the PTZ camera. Remove the PTZ camera carefully.

If any damage occurred during shipping please call our support line (617-467-3059) for assistance.

3.2 Connect Camera

This unit can be powered using 115 or 230 VAC.

NOTE: The cable for control and power is a single cable. Do not attempt to remove the cable or alter its installation in any way. The cable is a controlled element of the certification. The cable is potted in place.

The cable is shipped with green quick disconnect connector(s) for bench testing purposes only. These green quick disconnects must be removed on final installation per EN60079-1:2007 OR.

Locate the control wires. RS485 cable is divided in: blue (A) and purple (B). Connect the RS485 control wires to your controller input. Configure your controller device to match the baud rate (2400) and ID settings on the PTZ camera. Move the PTZ camera up, down, left, right and confirm that you are able to see the PTZ camera move in the corresponding direction.

3.3 Camera Cable

The camera is provided a pigtail cable that is installed at the factory and is configured as illustrated below.

Wire Table		
Function	Color	Type
115 or 230 VAC Line	Black	Straight
115 or 230 VAC Neutral	White	Straight
115 or 230 VAC Ground	Green	Straight
Positive - RS485 Control	Orange/Orange-white	Twisted Pair
Negative - RS485 Control	Brown/Brown-white	Twisted Pair
Video	Black	Coaxial/BNC Termination over Twisted Pair

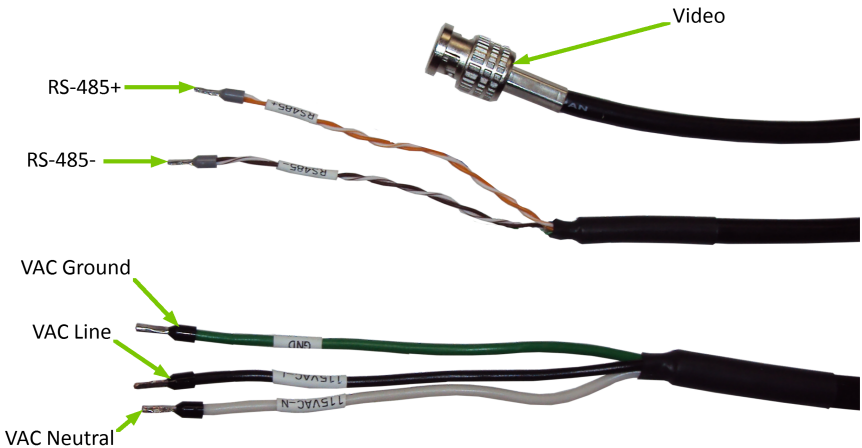

3.4 Verify Video

1. Connect the cable pigtail to your test equipment.
2. Power the camera.
3. Ensure proper initialization sequence for pan clockwise, pan counter-clockwise, tilt up, tilt down, zoom wide and zoom tele.
4. Check for clear video.
5. Check wiper operation.

3.5 Bench Test Completed

This concludes the bench test.

4

Configure IVC VMS Software (APTZ-3045-07 Only)

This chapter covers the settings for your IVC software that are unique to this camera. For more details on IVC software configuration and operation, consult the documentation provided with the software.

4.1 Relay Server Settings

To configure the APTZ-3045-07 in the Relay Server:

1. Enter the IP address of the Relay Server into your browser.
2. Login to the Relay Server when prompted for credentials. The user logging in must have sufficient rights to configure Relay Server.
3. Click on the **Management** link.
4. Click on the **Cameras** tab.
5. In the **Basic** menu, click **Camera**.
6. Click the **Camera** drop down menu and select an available ID number. Type a name for this camera in the corresponding text field.
7. Click the **Enable camera** check box.
8. In the **Encoder** drop down menu, select **I-R1**.
9. In the **IP address** text fields type the camera's IP address and Port number.
10. Enter the camera's username and password into the **Username and password** text fields.
11. Configure all other fields as shown below.

http://localhost:84/IVC/management.htm

Welcome admin

Quick Start Cameras Users Storage System

Basic

Camera
Video Capture
Video Display
Video Storage
Presets
Panoramas
PTZ Limits
Control Display

Advanced

Camera Settings
Connection Timeout
Pan Tilt Settings
GPS Settings
Restore Position
Auxiliary Buttons
Event Notification
Slave Camera
On-screen Display
Troubleshoot

Autonomous

Storage
Tour

Camera Setup

Camera

Camera: (Required) 20 ZO-HD39-1

State

Active: Enable camera

Encoder Type

Encoder: (Required) I-R1

Pan/Tilt: Select pan/tilt code Camera: Select camera code

Camera

IP address: 192.168.25.99 Port: 80 Channel: 0
(Required)

Username and password: system system

Image type: H.264 Stream ID: 0 Enable audio

Image resolution: Large Image quality: Normal

Frame rate: 0 fps NOTE: A value of zero will result in maximum camera frame rate

Control COM: 1 Device ID: 1

Camera orientation: Flip orientation

Submit Restore

Click on the **Help** link on the Relay Server page for more information on these settings and other camera settings (storage, presets, panoramas, etc.)

5

Mount the Camera

5.1 Deploy the PTZ

It is important to mount the PTZ camera to a solid, stable surface or pole. Refer to the drill pattern below (measurements shown in inches).

NOTE: Camera must only be mounted in an upright, vertical position. Mounting in any other manner, tilted, inverted, etc., **VOIDS THE RATING.**

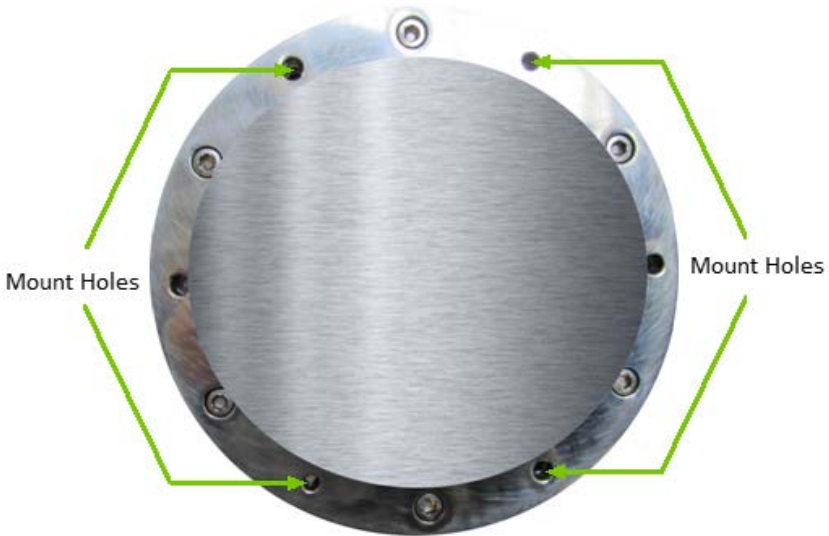

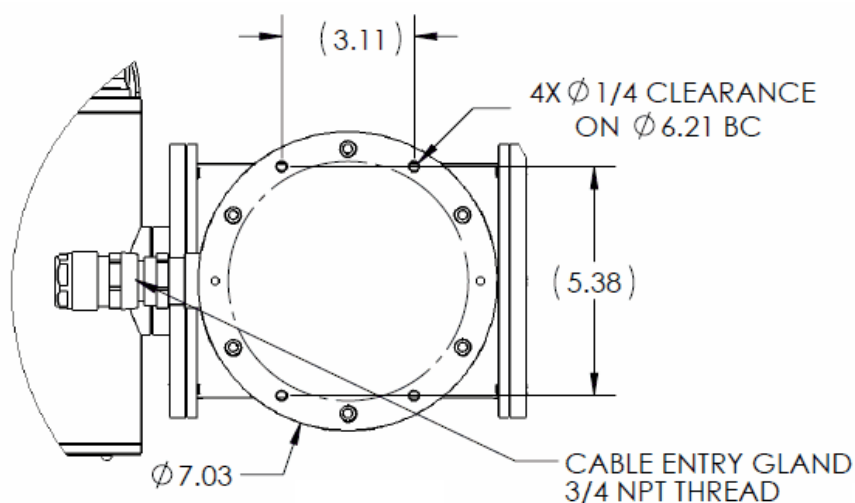

Ensure that there is sufficient clearance all around for complete operation of the camera (consult image below). Camera must be mounted in accordance with NFPA 70.

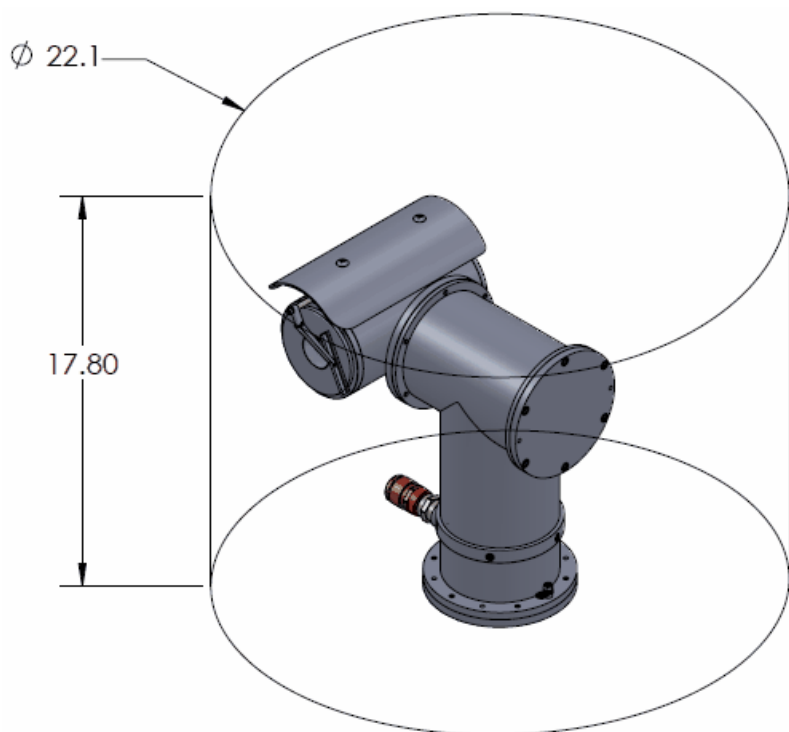

6

Support Information

6.1 Unit Service

This unit is not field-serviceable. Maintenance should involve a regular wash down of the unit, based on the camera environment.

6.2 Maintenance

Check cable for any sign of degradation.

Regular wash down as needed.

NOTE: Camera must never be opened when energized.

6.3 Contact IVC

If you experience any problems please call us (617-467-3059) or email support@ivcco.com.

Please note that no equipment (in-warranty or out-of-warranty) should be sent back to IVC without an Return Material Authorization (RMA). Contact IVC support or your IVC sales representative for an RMA.

CAUTION: All installations must insure the camera assembly is mounted securely to ensure that it cannot become dislodged during high wind, accidental bumping or other such incidents. All wiring must comply with NEC, NFPA, and local codes.

NOTE: IVC is not liable for direct or consequential damages resulting from use of this product and IVC makes no guarantees regarding results of intended and unintended use of the product.

6.4 Spare Parts

IVC PART NUMBER	DESCRIPTION
SP1001	Wiper Arm
SP1002	Wiper Blade



Appendix A - Specifications

APTZ-3045-07	
Imager	1/2.8" CMOS
Shutter	1/25 to 1/10,000 seconds
Minimum Illumination	Color: 0.05 Lux B/W: 0.02 Lux
White Balance	Auto and Manual
Iris	Auto and Manual
Focus	Auto and Manual
View Angle	2.34° - 59.8°
Focal Length	4.5 – 144.0 mm
F-number	1.6 - 4.8
Zoom ratio	30x Optical
Pan Angle	360°
Pan Speed	40° per second
Tilt Angle	-90° to 90° (180° view range)
Tilt Speed	40° per second
Frame Rate	30 FPS
Ethernet	100BASE-T (RJ-45)
Protocols	IPv4, TCP/IP, UDP, HTTP, RTP/ RTCP/RTSP, FTP, DDNS, NTP, IGMP, ICMP
Resolution	1920 x 1080
Weight	48.5 lbs.
Voltage Required	90 - 240 VAC
Current	= 500mA
Operating Temperature	-25° to 50° C
Dimensions	15.73" H x 13.97" W x 10.31" D
Mount	Pedestal
Protection Class	NEMA TYPE 4
Approvals	Class I Division 1 Groups B, C, & D T6 Tamb +50°C (+122°F) Class I Zone 1 Group IIB H2

	APTZ-3045-04
Imager	1/4" type EXview HAD CCD (Progressive Scan)
Shutter	1 to 1/10,000 seconds
Minimum Illumination	1.4 lux
Exposure	Auto
White Balance	Auto
Iris	Auto
Focus	Auto
View Angle	1.7° - 57.8°
Focal Length	3.4 - 122.4 mm
F-number	1.6 to 4.5
Zoom ratio	36x Optical
Pan Angle	360°
Pan Speed	45° per second
Tilt Angle	-90° to 90° (180° view range)
Tilt Speed	45° per second
Ethernet	N/A
Protocols	N/A
Frame Rate	N/A
Video Output	1.0Vp-p; 75Ω

	APTZ-3045-04
Protocol	Pelco-D
Resolution	550 TVL
Voltage Required	90-240 VAC, 50/60 Hz
Current	Less than or equal to 500mA
Operating Temperature	-40°C To +50°C
Weight	48.5 lbs
Dimensions	15.3" H x 13.4" W x 9.2" D
Mount	Pedestal
Rating	Class I Groups B, C, & D T6 Tamb +50°C (+122°F) NEMA TYPE 4

8

Appendix B - Ethernet Extender

If you received a junction box containing an Ethernet extender, install it as described below.



As pictured above the junction box is provided with cable glands for cable entry. Killark Hubbell GUM-2-EX fittings are installed into the 3/4" NPT cable entries.

1. Unscrew the enclosure lid to access the extender.



2. Pass camera's Ethernet cable through cable gland and connect to Ethernet extender as indicated below.

3. Pass network cable from PoE injector (provided with junction box) or PoE switch through cable gland and connect to Ethernet extender as indicated below.

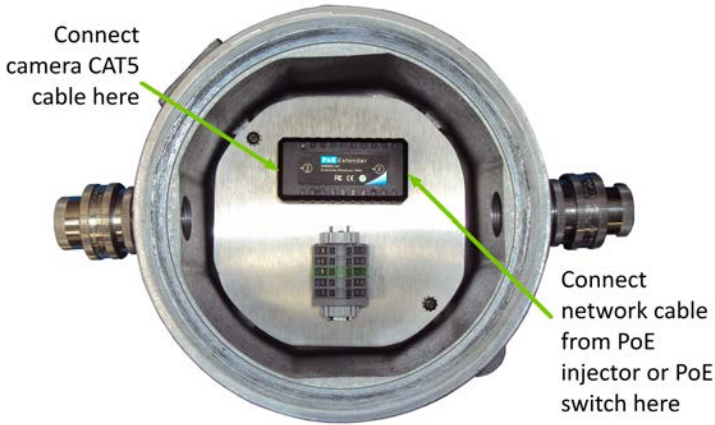

4. Replace enclosure lid.

NOTE: The Ethernet extender will not function until power applied to the PoE injector or PoE switch. If using the PoE injector provided, connect as pictured below. Maximum cable distance to/from injector is 100m.

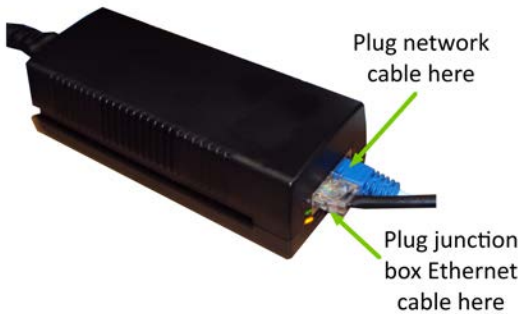

It is important to mount the APTZ-3045-07 to a solid, stable surface or pole. If this equipment is to be bolted to a flat horizontal surface, refer to the drill patterns (below). All dimensions shown in inches.

- A 7.75
- B 7.75
- C 6.375
- D 6.375
- E 0.4375
- F 5.625
- G 4.5625

