

| REVISION HISTORY | | | |
|------------------|-------------|-----------|----------|
| REV | DESCRIPTION | DATE | APPROVED |
| 0 | ECO-02006 | 7/27/2007 | JL |

| Bill of Material | | | | | |
|------------------|----------------|-----|-----------------------------------------------------------------|--------------------|-----|
| ITEM | PART NUMBER | QTY | DESCRIPTION | FILE NAME | REV |
| 1 | SCR1032X1/2BLK | 4 | #10-32 x 1/2"L PAN HEAD PHIL TYPE 23 , BLACK | SCR1032X500BLK.ipt | - |
| 2 | TPES-2F10X100 | 1 | TOP PANEL FOR ES FRAMES, TWO 10" DIA. FAN CUTOUTS | I005843.ipt | 0 |
| 3 | 721710 | 2 | 10" FAN KIT ORION OA254AP-11-1TB, ROTRON 040458, CORD, 2 GUARDS | 721710.iam | |

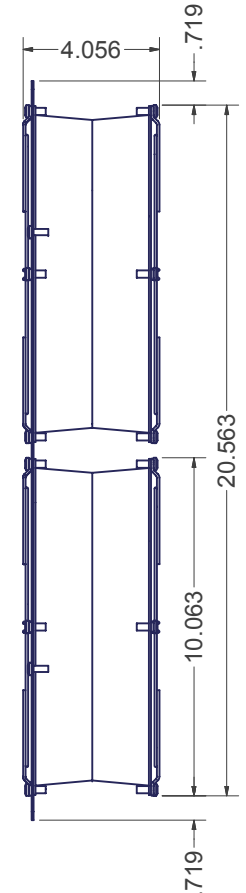
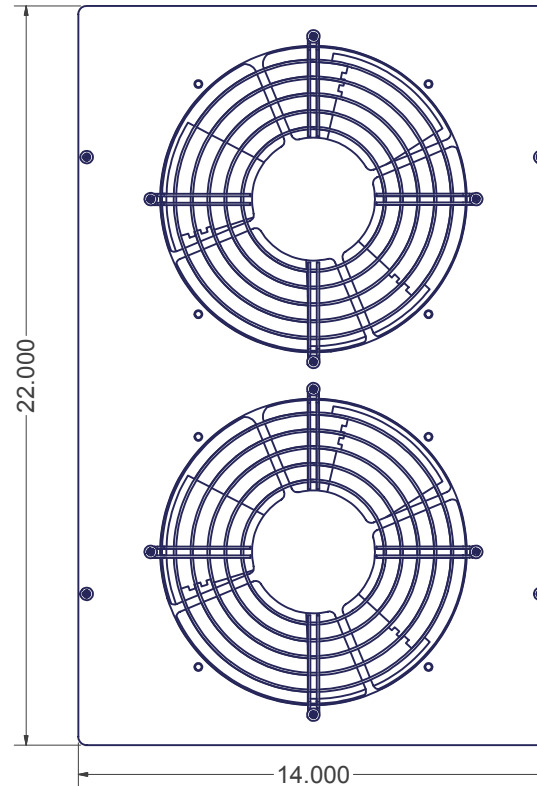
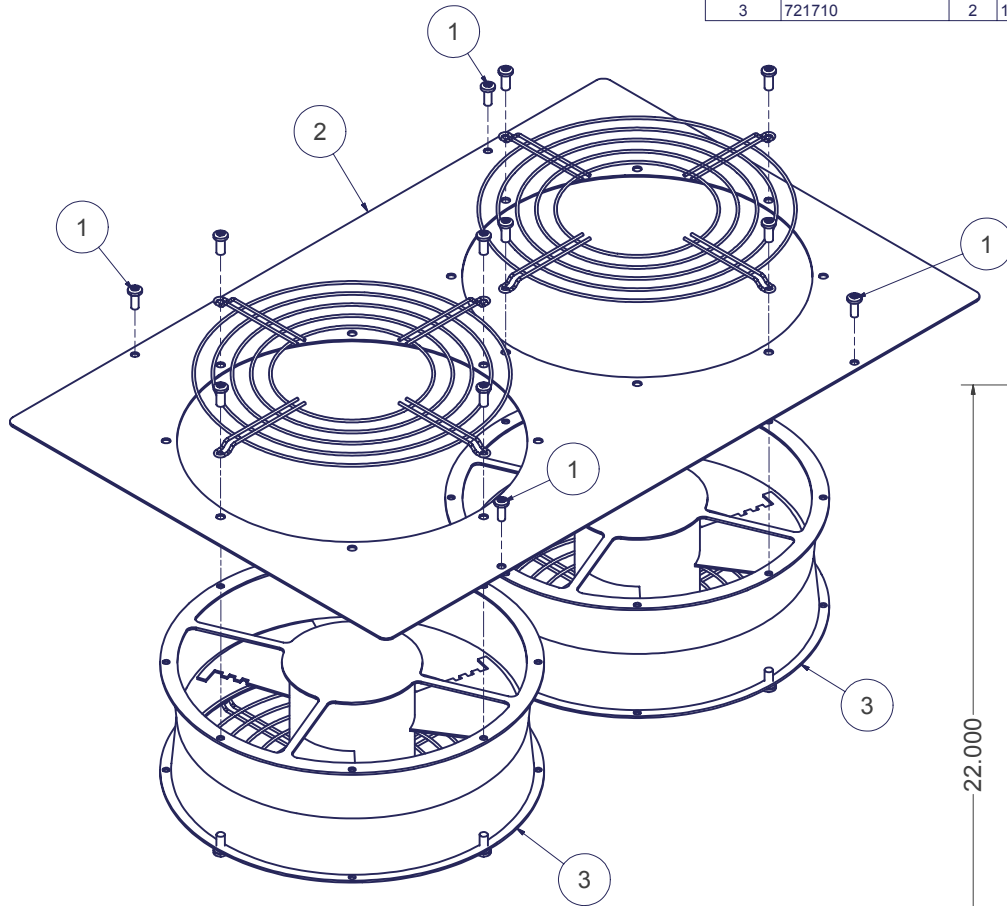

- A) CFM: 550 per fan
- B) VAC: 115 per fan
- C) Hz: 50/60 per fan
- D) Watts: 67/6 per fan1
- E) Line Amps: .48/.50 per fan
- F) dBA: 45.4 per fan

| |
|---------------------------------------------------------|
| INTERPRET DRAWING PER ASME Y14.5M-1994 |
| DIMENSIONAL LIMITS APPLY AFTER APPLICATION OF FINISH |
| DRAWING NOT TO SCALE |
| TOLERANCE UNLESS OTHERWISE NOTED: |
| ANGULAR +/- 1- |
| .XXXX +/- .010 |
| .XXX +/- .015 |
| .XX +/- .030 |
| X FOR REF. ONLY |
| UNLESS OTHERWISE SPECIFIED ALL DIMENSIONS ARE IN INCHES |

NOTICE:
Use of this document is subject to a confidentiality and nondisclosure agreement with Great Lakes Case & Cabinet Co., Inc. (GLCC) and may not be reproduced, disclosed or utilized in whole or in part without prior written authorization from GLCC.

| | |
|-----------------|-----------|
| PART NUMBER: | TPES-2F10 |
| QTY PER UNIT: | 1 |
| MATERIAL TYPE: | - |
| MATERIAL GAUGE: | #16 GA |
| FINISH: | - |
| DRAWN | DATE |
| JL | 7/26/2007 |
| CHECKED & APP. | DATE |
| WSS | 7-27-07 |

| | | |
|-----------------------------------------|----------------------------------------------------------|---------------|
| TITLE | TOP PANEL FOR ES FRAMES WITH TWO 10" DIA. FAN ASSEMBLIES | |
| GREAT LAKES CASE & CABINET CO., INC. | | |
| P.O. BOX 551 EDINBORO, PA 16412 | | |
| PHONE (814) 734-7303 FAX (814) 734-3907 | | |
| E-MAIL glcc@greatcabinets.com | | |
| DWG NO: | REV | SHEET: 1 OF 1 |
| I005842 | 0 | |

