

CATALOG NUMBER	DESCRIPTION	COLOR
FCR1U3SPX	1U FIBER ENCLOSURE	BLACK
FCR1U3SPXW	1U FIBER ENCLOSURE	WHITE

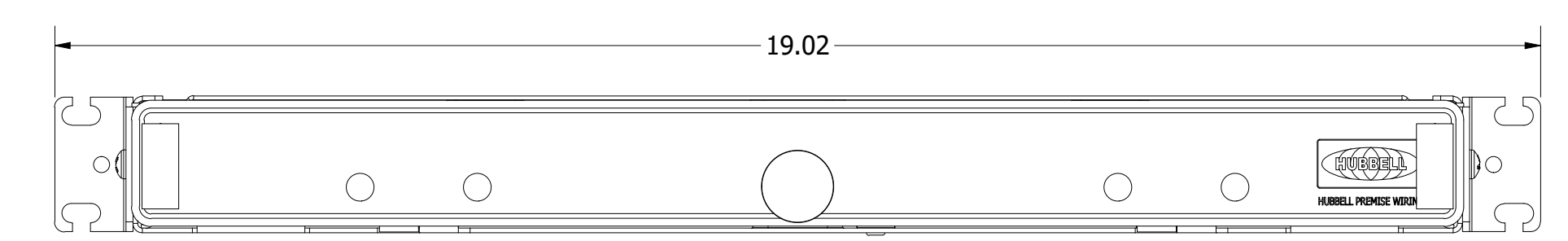
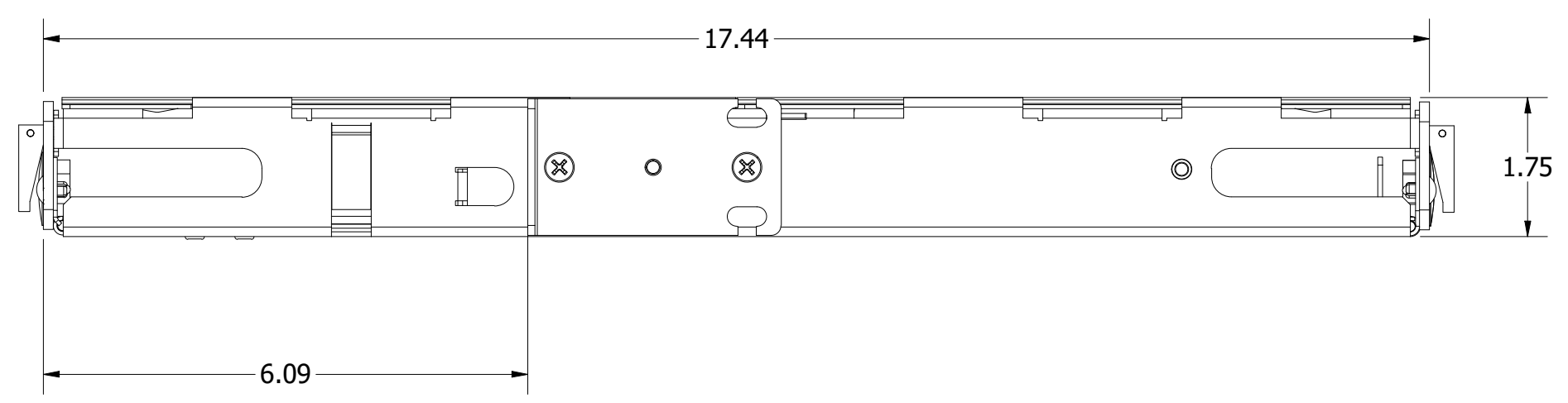
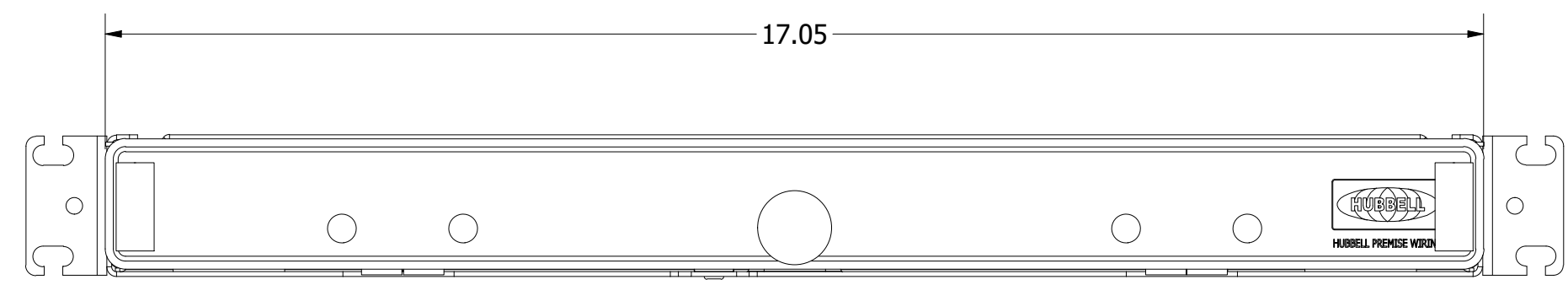
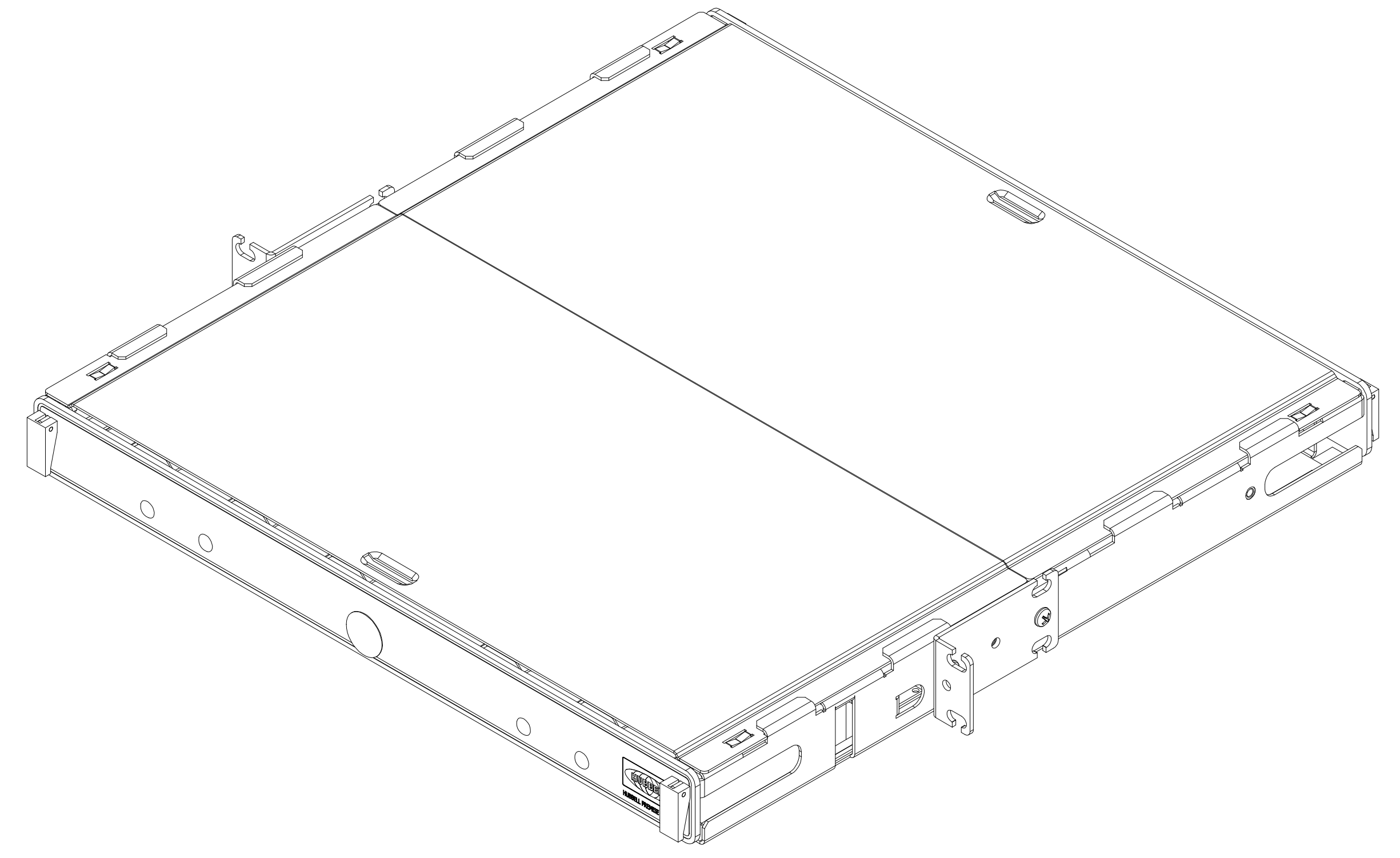
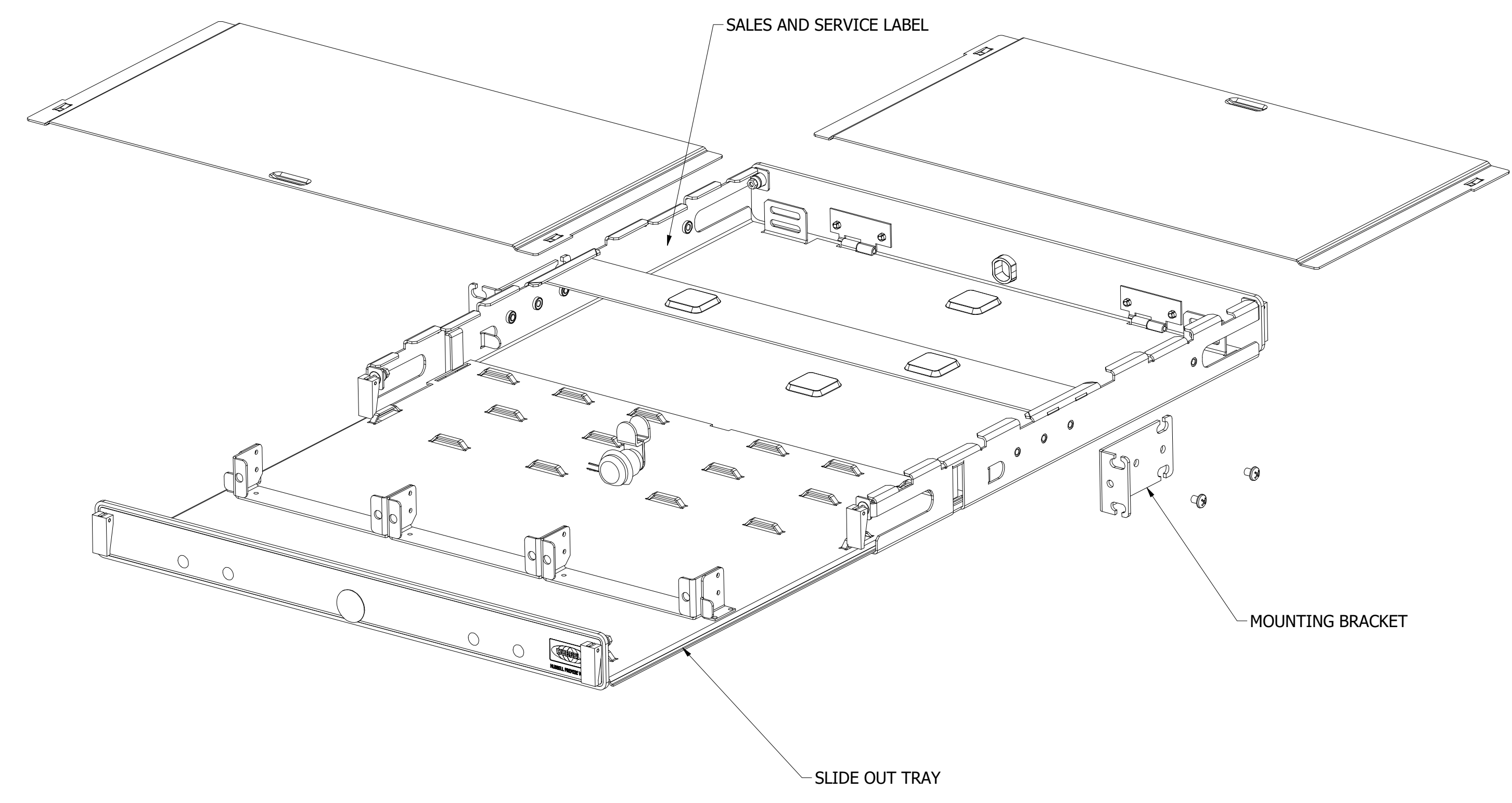

NOTES:
 1. SURFACE FINISH: POWDER COAT, SEE CATALOG TABLE FOR COLOR.
 2. SPECIFICATIONS SUBJECT TO CHANGE WITHOUT NOTICE.

ACCESSORY KIT	
DESCRIPTION	QTY.
WIRE TIE, 10.75", BLACK	8
#12-24 HARDWARE PACK	1
DANGER LABEL	1
VELCRO FASTENER STRAP, 2 FT ROLL	1
INSTRUCTION SHEET	1
PLASTIC FIBER ROUTING SPOOL	4
LABEL SHEET	2
LABEL HOLDER	2

Created on INVENTOR	DIMENSIONING AND TOLERANCE PER ANSI Y14.5M-1982 UNLESS OTHERWISE SPECIFIED, DIMENSIONS ARE IN INCHES (MM). TOLERANCES: XX = ±.01 (.25) .XXX = ±.005 (.127) .XXX = ±.0025 (.0635) ANGLE TOL ±1°	PROJECT REFERENCE: NPD-03747	
	IN ACCEPTING OUR DRAWINGS, BLUEPRINTS, OR SUPPORTING DOCUMENTATION FOR QUOTATION OR OTHER PURPOSES, YOU AGREE NOT TO DISCLOSE TO OTHERS THE IDEAS, INFORMATION, OR DESIGNS SHOWN HEREIN, AND THAT YOU WILL MAKE NO USE OF SAME WITHOUT PERMISSION	DRAWN BY: D.O'CONNOR 5/10/23	HUBBELL Hubbell Premise Wiring HUBBELL INCORPORATED (Delaware) 23 Clara Drive, Mystic, Connecticut 06355
		CHECKED BY:	TITLE: FCR1U3SPX ENCLOSURE ASSEMBLY
		APPROVED BY:	SIZE DRAWING NO. D HWS15216C

1	230421029756	5/10/23	INITIAL RELEASE	DPO	MMA
REV.	ECN	DATE	DESCRIPTION	CHG BY	APPD BY

SCALE:	SHEET 1 OF 1	REV. 1
--------	--------------	--------