

REV	DESCRIPTION	DATE	APPROVED
0	ECO-018176	2/23/2007	WSS
1	ECO-01921	4/17/2007	WSS
2	ECO-02358	8/19/2008	FED

ITEM	PART NUMBER	QTY	DESCRIPTION	FILE NAME	REVISION
1		2	TAB, LEFT HAND FOR MOUNTING STATIONARY ADJUSTABLE SHELVES - 18" DEEP VERSION	I005340.ipt	0
2	7206FRA18X101	1	19" EIA SHELF, 18" DEEP SUB ASSEMBLY & DETAIL	I005093.iam	2
3	H01-047	4	SCREW, 8-32x3/8" Ph PAN TYPE 23 BLACK OXIDE/WAX RoHS	SCR832X375BLK.ipt	-
4		2	TAB, RIGHT HAND FOR 18" DEEP FRA SHELF.	I005341.ipt	0

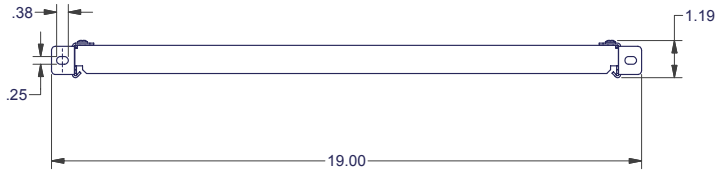
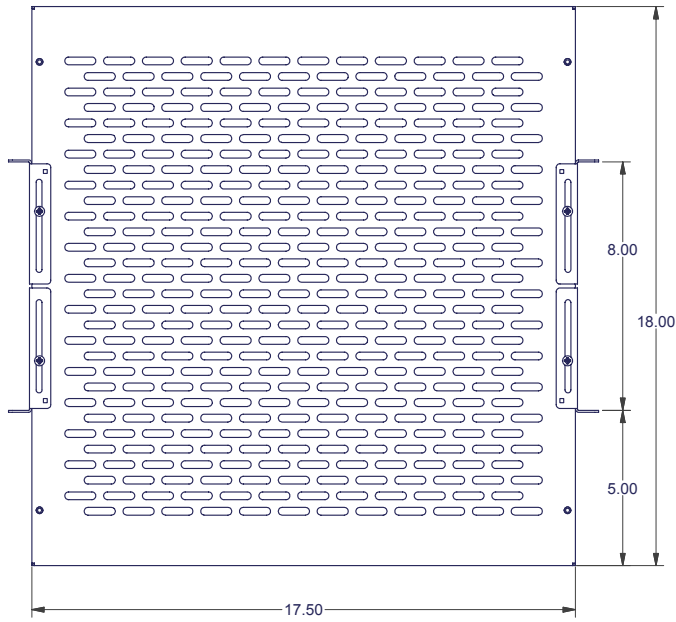

**SPECIAL NOTES:**

1) ASSEMBLE ITEMS #1,#2 & #3 WITH #4 USING THE SQUARE ALIGNMENT HOLES FOR TAB PLACEMENT (12.00").

2) SHELF DATA:

- A) SHELF DIMENSIONS: 17.50"W x 18"D x 1.0"H
- B) RACK MOUNTING: 19" EIA
- C) WEIGHT CAPACITY: 150 LBS.
- D) STANDARD TAB PLACEMENT: 8.00"
- E) MAXIMUM TAB PLACEMENT : 21.5"

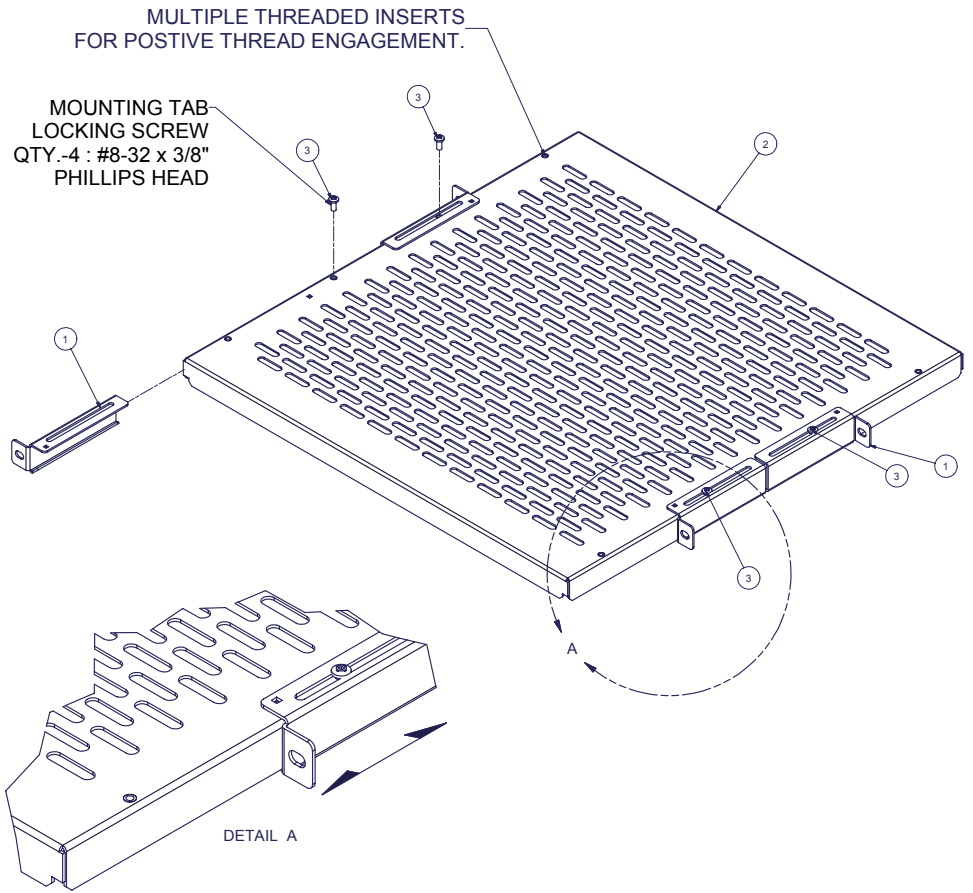

<small>INTERPRET DRAWING PER ASME Y14.5M-1994</small> DIMENSIONAL LIMITS APPLY AFTER APPLICATION OF FINISH <small>DRAWING NOT TO SCALE</small> TOLERANCE UNLESS OTHERWISE NOTED: ANGULAR +/- 1- .3000X +/- .010 .XXX +/- .015 .XX +/- .030 X FOR REF. ONLY UNLESS OTHERWISE SPECIFIED ALL DIMENSIONS ARE IN INCHES	<b>NOTICE:</b> Use of this document is subject to a confidentiality and nondisclosure agreement with Great Lakes Case & Cabinet Co., Inc. (GLCC) and may not be reproduced, disclosed or utilized in whole or in part without prior written authorization from GLCC.	PART NUMBER: <b>7206FRA18</b>	TITLE: <b>19" EIA 4 POINT SHELF, 18" DEEP TOP LEVEL ASSEMBLY.</b>
		QTY PER UNIT: 1	MATERIAL TYPE: C.S.
		MATERIAL GAUGE: .015 GA.	
		FINISH: POWDER COAT.	<small>P.O. BOX 551 EDINBORO, PA 16412</small> <small>PHONE (814) 734-7303 FAX (814) 734-3607 E-MAIL glcc@greatlakes.com</small>
DREVW: SRES	DATE: 2/23/07	DWG NO: I005092	REV: 2
CHECKED: JAL	DATE: 2/23/07	SHEET 1 OF 1	