

# DL210 NET 2.0, DL210 NET D 2.0

Digi-Loop™ Large-area dual-output loop amplifiers



Digi-Loop is definitely state-of-the-art – the first of its kind to maximize modern amplifier technology. Its network-control capability provides seamless, remote system set-up, operation and monitoring via laptop or tablet. DSP audio processing offers flexible, powerful software control of mixing, equalization, compression and more. Powerful Class D, pulse-width amplifiers maximize efficiency.

### FEATURES / BENEFITS

- Network control - allows control and calibration of unit remotely with application software
- High continuous current 12 A<sub>rms</sub> (17 A<sub>pk</sub>) per output continuous
- LCD Screen with VU metering, easy one-button menu control
- DSP Audio Processing
- Dante™ Input
- USB for firmware updates
- Input mixing, parametric equalization, compression, metal loss compensation, high and low-pass filters, AGC and audio delay
- Power-save mode
- Adjustable output delay for multiple amps in large venues

The Digi-Loop's amplifier design offers dual 12 Arms loop outputs for perimeter loop(s), single array(s), dual loop, or phased-array configurations. A 70-100 V input provides connection to a distributed speaker/paging system, ensuring announcements are heard by loop users.

- Fault warning and active protection against shorted or open circuits and overheating
- Loop fault relay output (via RS-232 DB-9 connector)
- Two 3-position terminal block inputs configurable as microphone input or line-input, balanced or unbalanced.
- Standard 2 RU, 19" rackmount
- Magnetic signal couples directly to devices equipped with telecoils (T-coils) such as hearing aids, cochlear implants, or optional loop receivers.
- Suitable for phased-array or dual-loop systems.
- Phased-array mode automatically produces 90° phase shift in slave loop output
- Speaker mode - switches one loop output to drive a passive speaker
- Meets ADA / ADAAG guidelines.

# Digi-Loop™ Large-area dual-output loop amplifier with Dante™ input

## Front View

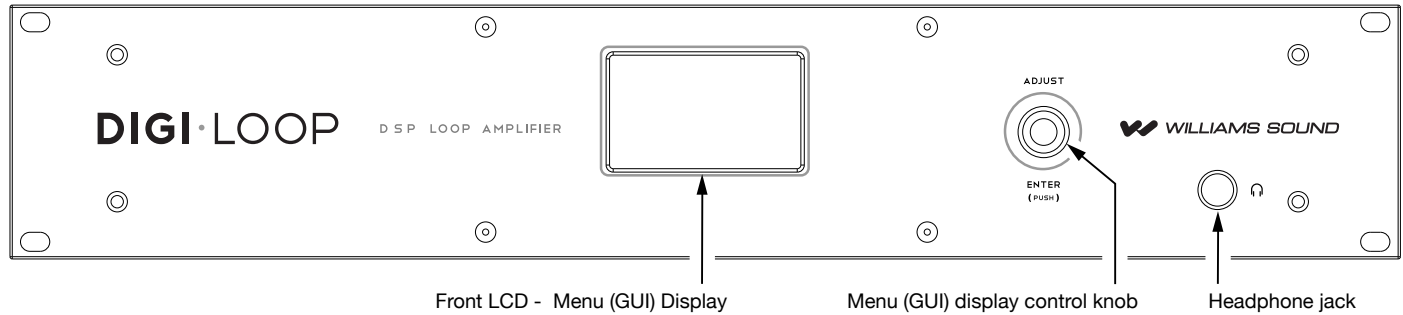

## Rear View

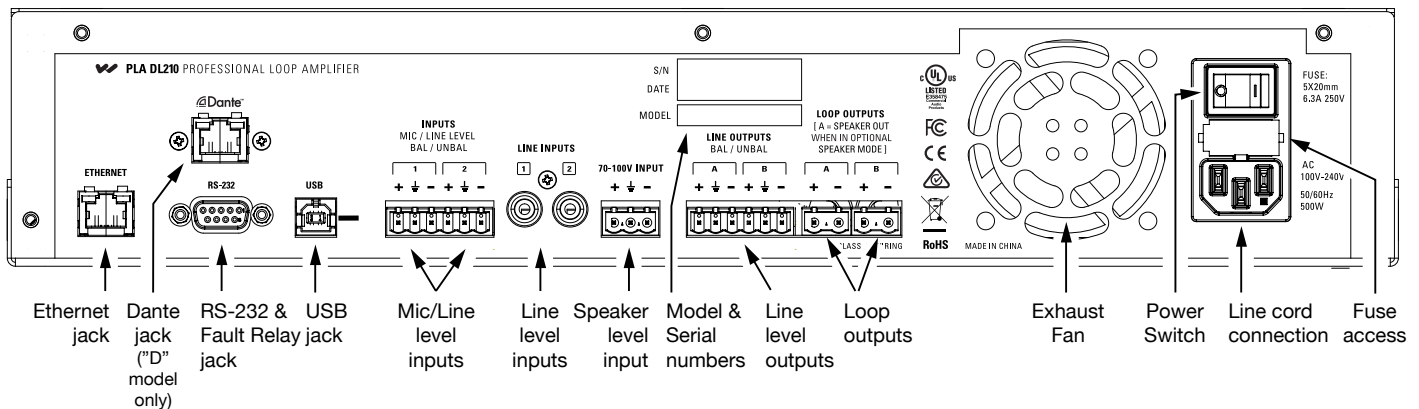

Note: the DL210 NET 2.0 does not have a Dante jack.

## Architectural / Engineering Specifications

The loop amplifier shall have a RJ-45 ethernet jack to provide configuration capability over an ethernet (10 base T) network.

It shall have an RJ-45 Dante ethernet jack.

It shall have a USB jack to provide firmware upgrades to the amplifier using a computer.

It shall have two MIC/LINE LEVEL 3-pole terminal block inputs, balanced or single-ended, with 48 V phantom supply in microphone mode.

It shall have a configurable PRIORITY INPUT function.

It shall have a 70-100 V, 2-pole terminal block input, to provide a high/speaker-level input connection for use with distributed speaker systems.

It shall have an internal frequency generator for calibration providing 100 Hz, 500 Hz, 1 kHz, 2.5 kHz and 5 kHz tones, and Pink Noise.

It shall have two LINE OUTPUTS, balanced or single-ended to provide loop-through connections for line level signals going to other equipment such as recording devices or additional loop amplifiers.

It shall have a 1/4" Headphone jack on front panel for monitoring of inputs or outputs, selectable in the menu.

It shall have a loop fault relay output (NC,NO,C) for triggering external systems when a loop fault occurs. This shall be integrated into the RS-232 DB-9 connector.

It shall provide an output drive voltage of up to  $33.3 V_{rms}$ ,  $47.6 V_{pk}$  per output.

It shall provide an output current of up to  $12 A_{rms}$ ,  $17 A_{pk}$  per output.

It shall have a front control interface consisting of a backlit LCD screen and control button/dial.

It shall have adjustable settings for input mixing, parametric equalization, compression, frequency-shaping, metal loss compensation, high and low-pass filters, AGC and audio delay.

It shall display warnings for LOOP FAULT (open loop, shorted loop or out of impedance range), OVER TEMP, and CLIPPING. It shall have protection against loop faults and overheating (amplifier shuts down).

It shall be controllable by devices such as a Windows Surface Tablet, or PC, with PC App software installed.

It shall be compatible with either US or international power systems with the appropriate power cord.

The loop amplifier shall be the Williams AV model **DL210 NET 2.0**.

The loop amplifier *with the Dante input* shall be the Williams AV model **DL210 NET D 2.0**.

# Digi-Loop™ Large-area dual-output loop amplifier with Dante™ input

## Specifications:

### GENERAL

Dimensions	2 RU Rackmount, 19" W x 3.5" H x 12" D. Chassis is 17" W.
Weight	14.3 lbs (6.5 kg)
Color	Case: Black, white and blue legends on front, white legends on back. LCD: Backlit Blue.
Fan cooling	Variable Speed, Temperature Controlled
Power supply	Internal, Universal 100-240 VAC, 50/60 Hz, 250 Watt. Fuse: 5 x 20 mm, 5 A, 250 V. AC power plug is IEC 320-C14.
Heat output @ 120 VAC	Sleep state: 100 BTU/hr; Idle state: 146 BTU/hr; Driving two loops @ 12 A each: 1,040 BTU/hr
Ethernet	(1x) RJ-45; 10-100 MBps.
USB	(1x) standard-B. USB 1.1, 2.0 or 3.0 supported.
RS-232/Loop fault relay	(1x) DB-9 jack. RS-232: Pin 2=Tx, Pin 3=Rx, Pin 5=gnd. Loop fault relay: Pin 1=NC, Pin 4=Common, Pin 6=NO. Relay contact rating: 2.0 A @ 30 VDC.
Environment	0-35° C ( 32-95° F), 0-90% relative humidity.
Coverage area*	31,400 sq. ft. (2,917 sq. m.) (Perimeter Loop, 1:1 aspect ratio, both outputs driven) 51,660 sq. ft. (4,800 sq. m.) (Perimeter Loop, 3:1 aspect ratio, both outputs driven)

### INPUTS

Dante input	DL210 NET D 2.0 model only. (1x) RJ-45;100 Mbps. Minimum latency: 2 ms. Audio sample rates supported: 44.1, 48 kHz. Resolution: 24 bits.
Mic/Line inputs	(2x) 3-position terminal block, input impedance=1.5 kΩ Mic, 10 kΩ Line. Configurable/Accepts: Mic, Line -10 dBV, Line +4 dBu, or Line +8 dBu, balanced or unbalanced. Phantom supply (48V).
70-100 V input	(1x) 2-position terminal block; high/speaker-level input (accepts 25 V, 70 V or 100 V) from distributed audio/paging systems.

### OUTPUTS

Line outputs	(1x) 3-position terminal block; loop-through of Mic/Line Input 1 & Line Input 2, +4 dBu, Balanced or Unbalanced. The line outputs mirror the audio of the loop output.
Loop output(s)	(1x) 2-position terminal block per output
Audio output delay	Adjustable from 0 to 165 msec
Headphone output	(1x) 1/4" stereo headphone jack, on front of unit. Monitored input or output selectable in menu.
Loop fault relay	Integrated into RS-232 DB-9 jack. Pin 1=NC, Pin 4=Common and Pin 6=NO. Contact rating: 2.0 A @ 30 VDC.
Loop output drive voltage	33.3 V <sub>rms</sub> (47.1 V <sub>pk</sub> ) continuous
Rated loop output current*	12 A <sub>rms</sub> (17 A <sub>pk</sub> ) per output
Loop resistance range	0.5 Ω to 3.0 Ω (DC)
Speaker output	Integrated into Loop Output A terminal block (switchable in menu). 225 Watts x 1 channel @ 4Ω, 125 Watts x 1 channel @ 8Ω, (Class D). Frequency response = 20 Hz-20 kHz, THD=0.07%.

### AUDIO

Rated load*	0.5 Ω DC with 135 μH inductance
Loop frequency response	45 Hz to 9.0 kHz ± 2 dB (1 kHz ref.)
Rated loop THD*	<1% at rated output current (1 kHz sine wave).

\*Test Specifications provided to the IEC 62489-1 standard.

**NOTE: SPECIFICATIONS SUBJECT TO CHANGE WITHOUT NOTICE.**

# Digi-Loop™ Large-area dual-output loop amplifier with Dante™ input

## Specifications (continued):

OTHER	
Front controls	Front LCD display menu access/adjustment via control button/dial.
Adjustable settings	Input mixing, parametric equalization, compression, metal loss compensation, high and low-pass filters, AGC and audio delay, output levels. See User Manual for adjustment range(s).
Internal calibration tools	Test tone generator with pink noise, loop current adjustment/matching. See User Manual for details.
Other features	Save/load configuration, loop test, priority input selection with adjustable threshold, loop fault relay, open/short and thermal protection. See User Manual for details.
Network control & firmware	Function control and calibration by DigiLoop PC App via ethernet (RJ-45). PC App requires Windows 7 or higher. Firmware updates through USB only.
Warranty	2 years
Approvals	CE, UL, ULC, FCC, Industry Canada, RoHS, WEEE, CB scheme, RCM

NOTE: SPECIFICATIONS SUBJECT TO CHANGE WITHOUT NOTICE.