

# Infrastruxure Power Distribution Unit with Network Management Card 2

60 kW

## Operation and Maintenance

PD60F6FK1, PD60G6FK1, PD60L6FK1, PDRPPNX10

12/2019



# Legal Information

The Schneider Electric brand and any trademarks of Schneider Electric SE and its subsidiaries referred to in this guide are the property of Schneider Electric SE or its subsidiaries. All other brands may be trademarks of their respective owners.

This guide and its content are protected under applicable copyright laws and furnished for informational use only. No part of this guide may be reproduced or transmitted in any form or by any means (electronic, mechanical, photocopying, recording, or otherwise), for any purpose, without the prior written permission of Schneider Electric.

Schneider Electric does not grant any right or license for commercial use of the guide or its content, except for a non-exclusive and personal license to consult it on an "as is" basis. Schneider Electric products and equipment should be installed, operated, serviced, and maintained only by qualified personnel.

As standards, specifications, and designs change from time to time, information contained in this guide may be subject to change without notice.

To the extent permitted by applicable law, no responsibility or liability is assumed by Schneider Electric and its subsidiaries for any errors or omissions in the informational content of this material or consequences arising out of or resulting from the use of the information contained herein.

# Table of Contents

Important Safety Instructions — SAVE THESE INSTRUCTIONS .....	5
Safety Precautions .....	6
System Overview .....	7
Display Interface.....	12
Top Dynamic Display.....	12
Main Menu Screen.....	13
Menu Tree.....	13
Configuration .....	14
Configure the System/Network .....	14
Configure the System ID .....	15
Configure the Network Management Interface .....	16
Connect the InfraStruxure PDU to the Network or to StruxureWare Data Center Expert .....	16
TCP/IP Configuration Overview .....	17
Device IP Configuration Wizard.....	17
BOOTP and DHCP Configuration.....	18
Configure TCP/IP Setting in the Command Line Interface with Local Access.....	19
Configure TCP/IP Setting in the Command Line Interface with Remote Access .....	20
Configure the Alarm Setup .....	21
Operation .....	22
Perform a Total Power Off .....	22
Restart the System .....	23
Access a Network Management Interface on a Configured InfraStruxure PDU .....	25
View the PDU Status Information .....	27
Load-Meter Screen .....	27
Volt-Meter Screen .....	27
Contacts Screen .....	27
Breakers Screen.....	28
Panel Screen.....	28
View the Electrical Configuration.....	30
Customization.....	31
Multi-Branch Cordset Adapters .....	31
PDU Orderable Part List.....	32
Maintenance .....	34
Download Firmware Updates .....	34
Reset to Factory Defaults .....	34
View the Manufacturer Data .....	34
Upgrade the PDU Monitor Firmware .....	35
Recover From a Lost Network Management Interface Password .....	36
Add a Breaker to the PDU .....	37
Add a Power Cable to the PDU .....	38
Test the EPO Switch .....	39
Connect Contacts/Relays to the PDU Monitoring Unit.....	41

Troubleshooting .....	43
Status and Alarm Messages .....	43

# Important Safety Instructions — SAVE THESE INSTRUCTIONS

Read these instructions carefully and look at the equipment to become familiar with it before trying to install, operate, service or maintain it. The following safety messages may appear throughout this manual or on the equipment to warn of potential hazards or to call attention to information that clarifies or simplifies a procedure.



The addition of this symbol to a “Danger” or “Warning” safety message indicates that an electrical hazard exists which will result in personal injury if the instructions are not followed.



This is the safety alert symbol. It is used to alert you to potential personal injury hazards. Obey all safety messages with this symbol to avoid possible injury or death.

## DANGER

**DANGER** indicates a hazardous situation which, if not avoided, **will result in death or serious injury**.

**Failure to follow these instructions will result in death or serious injury.**

## WARNING

**WARNING** indicates a hazardous situation which, if not avoided, **could result in death or serious injury**.

**Failure to follow these instructions can result in death, serious injury, or equipment damage.**

## CAUTION

**CAUTION** indicates a hazardous situation which, if not avoided, **could result in minor or moderate injury**.

**Failure to follow these instructions can result in injury or equipment damage.**

## NOTICE

**NOTICE** is used to address practices not related to physical injury. The safety alert symbol shall not be used with this type of safety message.

**Failure to follow these instructions can result in equipment damage.**

## Please Note

Electrical equipment should only be installed, operated, serviced, and maintained by qualified personnel. No responsibility is assumed by Schneider Electric for any consequences arising out of the use of this material.

A qualified person is one who has skills and knowledge related to the construction, installation, and operation of electrical equipment and has received safety training to recognize and avoid the hazards involved.

## Safety Precautions

This manual contains important instructions that must be followed during installation, operation, and maintenance of the PDU. For safety reasons, only trained users are allowed to operate the display interface

### **DANGER**

#### **HAZARD OF ELECTRIC SHOCK, EXPLOSION, OR ARC FLASH**

- Electrical equipment must be installed, operated, serviced, and maintained only by qualified personnel.
- The PDU must be installed in accordance with the National Electrical Code or the Canadian Electrical Code and all applicable local codes.
- Wear appropriate personal protection equipment (PPE) when performing maintenance on this PDU.

**Failure to follow these instructions will result in death or serious injury.**

### **DANGER**

#### **HAZARD OF ELECTRIC SHOCK, EXPLOSION, OR ARC FLASH**

Hazardous voltage from the branch circuit must be isolated from the 24VAC, 24VDC, and contact closure. If you do not use a CL2 cable, route the EPO wiring in conduit that does not contain any branch circuit wiring.

**Failure to follow these instructions will result in death or serious injury.**

### **WARNING**

#### **TIP HAZARD**

Do not tilt the PDU greater than 45° from its vertical axis. Never lay the PDU on its side.

**Failure to follow these instructions can result in death, serious injury, or equipment damage.**

### **CAUTION**

#### **UNPROTECTED OUTPUTS**

Apply circuit protection to all outputs.

**Failure to follow these instructions can result in injury or equipment damage.**

## EMI

This equipment has been tested and found to comply with the limits for a Class A digital device, pursuant to Part 15 of the FCC Rules. These limits are designed to provide reasonable protection against harmful interference when the equipment is operated in a commercial environment. This equipment generates, uses, and can radiate radio frequency energy and, if not installed and used in accordance with this user manual, may cause harmful interference to radio communications. Operation of this equipment in a residential area is likely to cause harmful interference. The user will bear sole responsibility for correcting such interference.

This Class A digital apparatus complies with Canadian ICES-003.

Cet appareil numérique de la classe A est conforme à la norme NMB-003 du Canada.

# System Overview

## InfraStruxure PDU

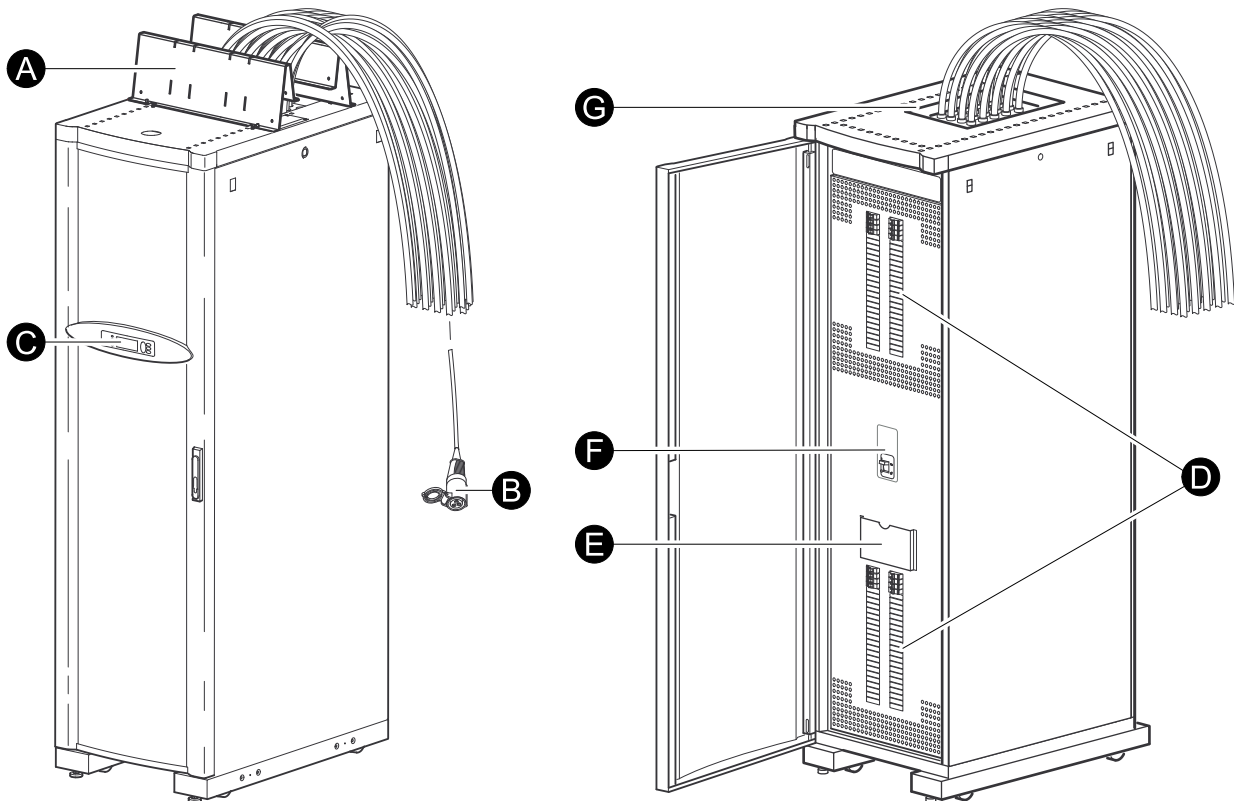

- A. PDU shielding trough.
- B. The PDU power cables supply power to equipment racks; they are fed through knockouts on the top of the PDU. The following two options are available for PDU power cables:
  - Multi-circuit power cable that terminates with an L21-20 outlet (shown).
  - Single-circuit power cable that terminates with an L6-30 outlet.
- C. Display interface.
- D. 42-position circuit breaker panels – each pole provides power at 120 V L-N or two single poles provide 208 V L-L. The amperage each position provides depends on the size of the circuit breaker used.
- E. The document pocket provides storage of documents relating to the circuit breaker panels, such as the PDU Panel Board Schedules (provided).
- F. The Main Output breaker protects the distribution circuit breaker panels (models with transformer only).
- G. The user connection plate is connected to the PDU monitoring unit, and provides easy access to input contact, output relay, network, and EPO connections. See *User Connection Plate*, page 11 for details.

### Rear View of PDU with Transformer

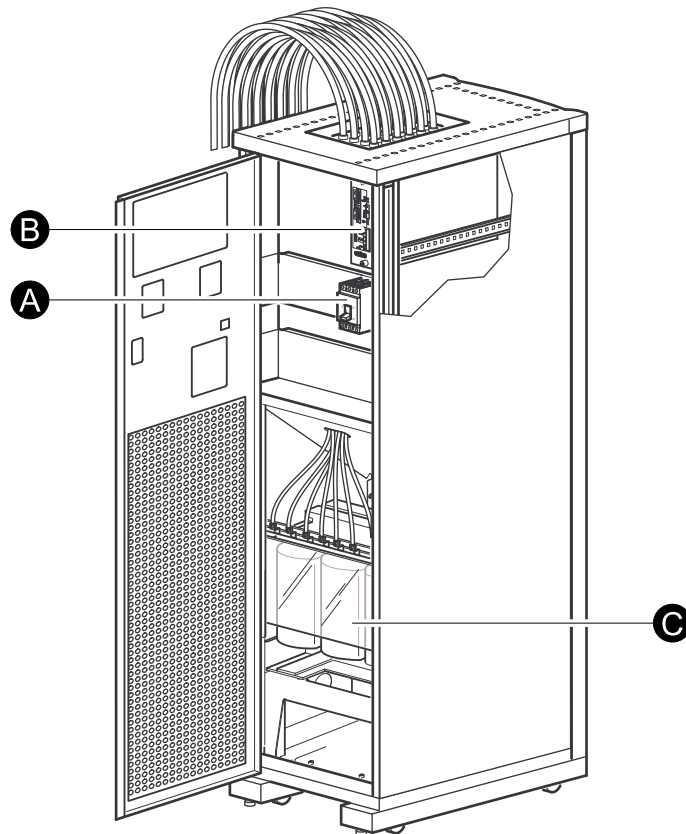

- A. The main input switch connects to the main power source. The switch accepts 208 V, 480 V, or 600 V input and requires 3-wire input conductors.
- B. The PDU monitoring unit has several current and voltage monitoring boards that report to a central board assembly located in the PDU monitoring unit. The monitoring unit has one 10/100 megabits per second (Mbps) Ethernet connection for access to the network or the StruxureWare™ Data Center Expert switch, four relay output connections, four input contact connections, and one EPO input connection. See *PDU Monitoring Unit*, page 10 for details.
- C. The delta-wye input transformer is based on the input voltage of the PDU input voltage (208 V, 480 V, or 600 V input). The output of the transformer feeds the input circuit breaker of the maintenance bypass panel. (Schneider Electric also offers a 208 V PDU without a transformer.)



### Rear View of PDU without Transformer

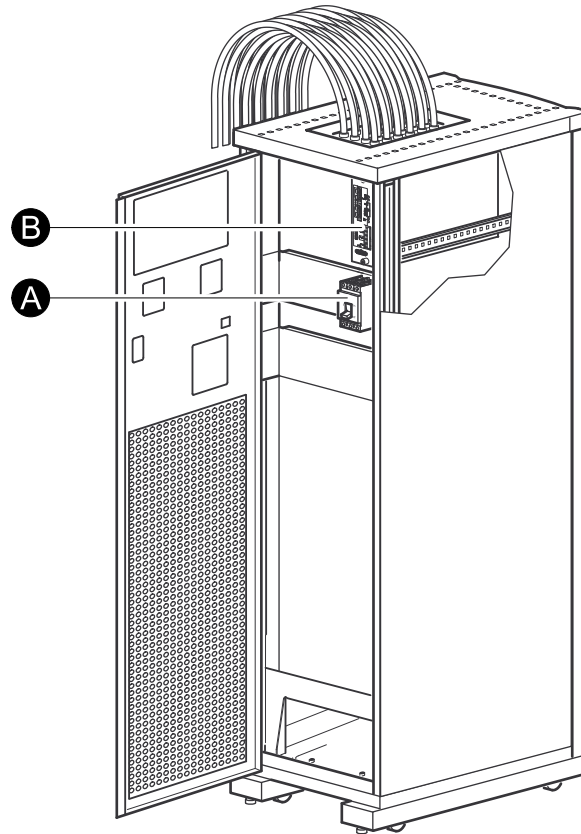

- A. The main input circuit breaker connects to the main power source. The breaker accepts 208 V input and requires 4-wire input conductors.
- B. The PDU monitoring unit has several current and voltage monitoring boards that report to a central board assembly located in the PDU monitoring unit. The monitoring unit has one 10/100 megabits per second (Mbps) Ethernet connection for access to the network or the StruxureWare™ Data Center Expert switch, four relay output connections, four input contact connections, and one EPO input connection. See *PDU Monitoring Unit*, page 10 for details.

## PDU Monitoring Unit

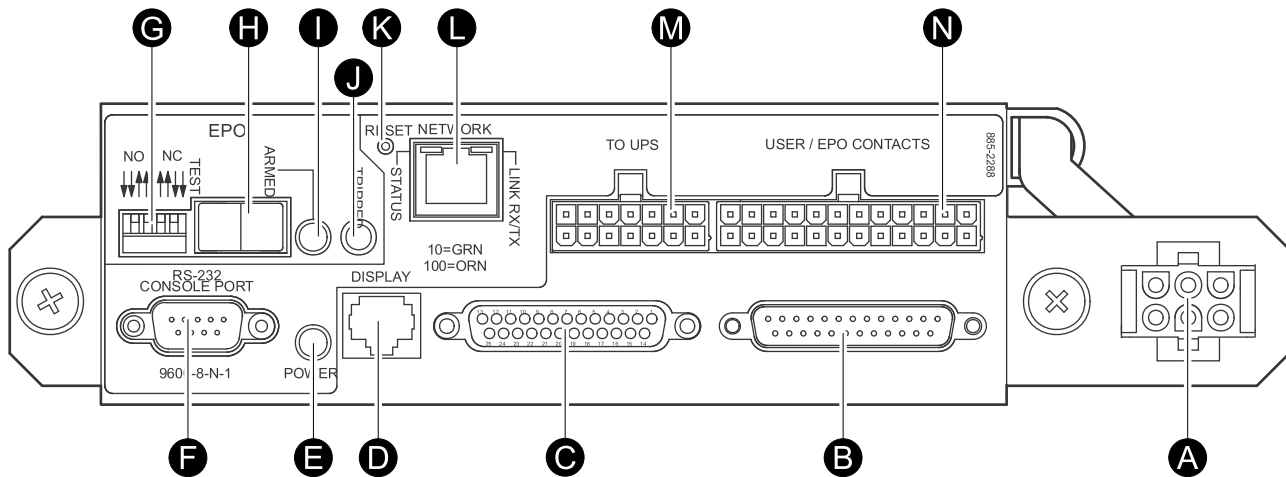

- A. This connection provides the input power for the PDU monitoring unit. The power is supplied by the monitoring unit circuit breaker on the front of the PDU. If the panel is on, and the monitoring unit circuit breaker is closed, the monitoring unit is powered.
- B. Connects to sensors, which monitor values such as voltage, current, and power.
- C. Digital input sensing for monitoring such as circuit breaker status, transformer temperature, fans, etc.
- D. The Display port (RJ-45) connects the PDU monitoring unit to the PDU display interface.
- E. The Power LED indicates whether the monitoring unit is receiving power from the AC output of the UPS. If the UPS is powered off, the LED remains lit – the EPO function is still available, however the monitoring unit is not powered.
- F. Use the Console port (DB-9) to connect a laptop computer to the monitoring unit using an appropriate SP cable (Schneider Electric part number 940-0103). This port is used to configure items relating to servicing the PDU.
- G. EPO DIP switches configure the EPO input for the type of EPO switch that is connected – Normally Open (NO) or Normally Closed (NC).
- H. When the EPO Arm/Test rocker is in the Test position, engaging the EPO switch will not cause the load to be powered off. When the rocker is in the Armed position, engaging the EPO switch will cause the PDU's main input switch and the Symmetra PX 40 UPS to be switched OFF. See *Test the EPO Switch*, page 39 for more information on testing the EPO switch.
- I. The EPO Armed LED is green when the rocker is in the Armed position. The LED is dark when the rocker is in the Test position.
- J. The EPO Tripped LED is red when the EPO switch is engaged (the EPO button is pressed), regardless of the state of the EPO Arm/Test rocker.
- K. The Reset button resets the network processor; it does not reset the PDU or the PDU monitoring unit.
- L. Connects to the network or StruxureWare Data Center Expert through the network port.
- M. Not used on this PDU model.
- N. The optional User/EPO Contacts port is connected to wire harnesses that connect to the user connection plate in the roof (or floor) of the PDU. The port allows for output relays (4), input contacts (4), and an EPO input (1). See *Contacts Screen*, page 27 and *Test the EPO Switch*, page 39 for more information.

**NOTE:** The branch current monitoring boards connect to the branch current monitor ports (RJ-11). These ports are on the top side of the PDU monitoring unit, and are labeled on the face of the unit. Each port corresponds to a section of circuit breakers on the PDU distribution circuit breaker panel: upper left = [01..41]; upper right = [02..42]; lower left = [43..83]; lower right = [44..84].

## User Connection Plate

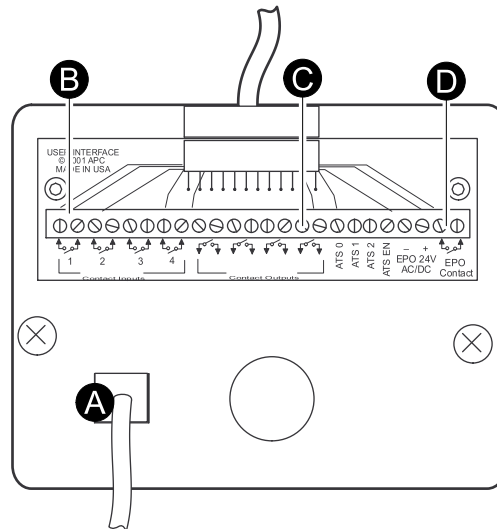

- A. Connect the InfraStruxure PDU to the network or the StruxureWare Data Center Expert through the ethernet port.
- B. The user connection plate has four input contact connections for monitoring Normally Open (NO) or Normally Closed (NC) dry contacts. See *Connect Contacts/Relays to the PDU Monitoring Unit*, page 41 for details.
- C. The user connection plate has four relay output connections for connection of Normally Open (NO) or Normally Closed (NC) dry contacts.
- D. Connect an Emergency Power Off (EPO) switch to one of the three choices of EPO connections (24 VDC, 24 VAC, or contact closure).

## Display Interface

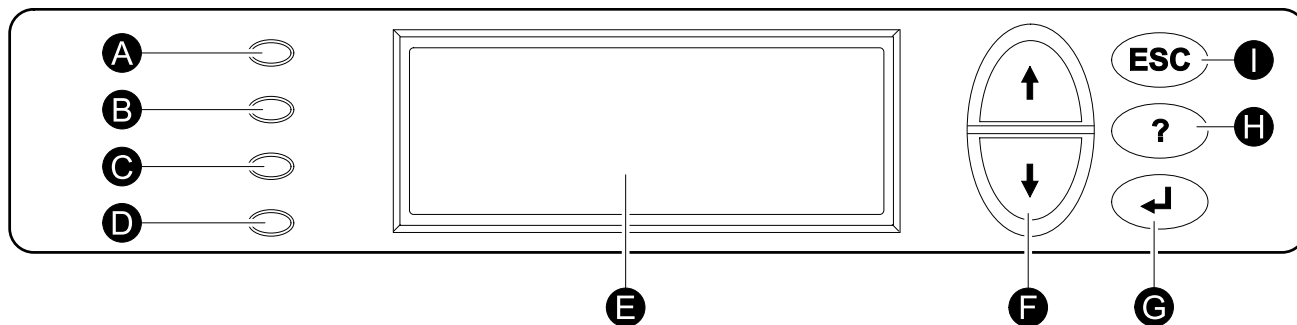

- |   |                         |                                                                                                                                                                                                                                                                |
|---|-------------------------|----------------------------------------------------------------------------------------------------------------------------------------------------------------------------------------------------------------------------------------------------------------|
| A | <b>Load Powered LED</b> | When green, all output phases are within the specified threshold limits of the output alarm.                                                                                                                                                                   |
| B | <b>Check Log LED</b>    | When yellow, at least one new alarm condition has been detected.                                                                                                                                                                                               |
| C | <b>Bypass LED</b>       | When yellow, power to the load is being supplied directly by the utility power source — the UPS has been removed from the circuit for maintenance or replacement. Bypass breakers on the PDU function as input circuit breakers to protect the load equipment. |
| D | <b>Alarm LED</b>        | When this LED is red, there are one or more alarms in the system.                                                                                                                                                                                              |
| E | LCD screen              | Displays alarms, status data, instructional help, and configuration items.                                                                                                                                                                                     |
| F | Arrow keys              | Scrolls through and select menu items.                                                                                                                                                                                                                         |
| G | Enter key               | Opens menu items and confirms changes to the system parameters.                                                                                                                                                                                                |
| H | Help key                | Opens context-sensitive help.                                                                                                                                                                                                                                  |
| I | <b>ESC key</b>          | Returns to the previous screen displayed.                                                                                                                                                                                                                      |

## Top Dynamic Display

When the system is running, the display interface will automatically scroll through a series of screens showing general information about the PDU and any active alarms on the system.

You can press the arrow keys to manually scroll through these screens.

Press the Enter key at any time to go to the main menu screen.

If the display interface is inactive for the duration of a user-configured time-out setting, it will return to the top dynamic display.

### Overview Screens

```
No Active Alarms
System Date/Time:
28-May-2019 10:37:01
```

Volts In		Volts Out	
L1-2:	000	L1	000
L2-3:	000	L2	000
L3-1:	000	L3	000

Load Current			
L1:	000	Neut	000
L2:	000		
L3:	000		

Total Output Loading			
kW:	000	PF:	000
kVA	000	%LD:	000
Freq:	00.0		

## Main Menu Screen

The main menu screen is the top-level screen on the display interface. The main menu contains eight submenus that allow you to monitor and configure specific aspects of the system.

Load-Meter	Alarms
Volt-Meter	Panel
Contacts	Config
Breakers	Help

**NOTE:** Pressing the UP arrow key when the first item in the main menu is selected will result in the cursor moving to the last item on the screen, and vice versa.

## Menu Tree

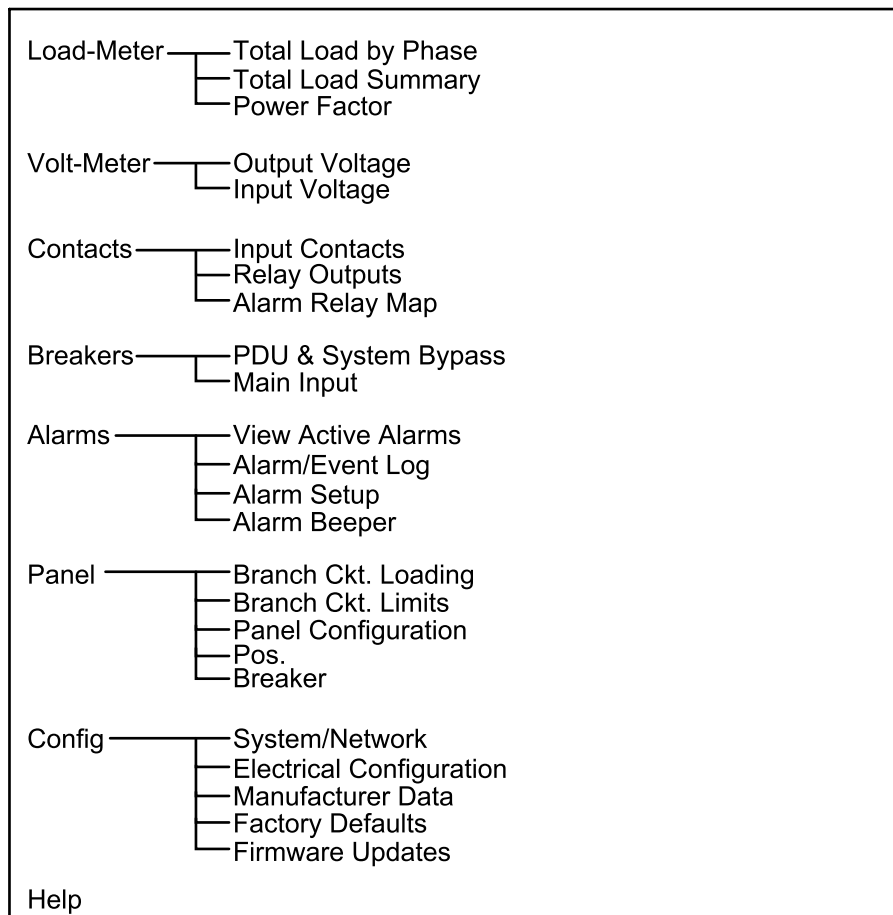

Some menus and screens are password-protected. Use the arrow keys and the Enter key to enter the password. Press the Enter key twice when the password is complete.

# Configuration

## Configure the System/Network

### Configure the System Password

From the main menu, select **Config > System/Network > System Password**.

- **Password:** Change the system password required to access protected screens and fields in the display interface. Enter a string of up to eight alphanumeric characters, followed by the underline character ( \_ ) to indicate the end of the string.
- **Time-out:** Set the time that the display interface waits for user input before it reverts to the initial scrolling of status screens. Select 1, 2, 5, 10 (the default), or 30 minutes; or 1, 2, or 4 hours, or Forever.
- **Invalidate NOW:** Re-enter the system password for viewing password-protected screens.

### Configure the Date/Time

From the main menu, select **Config > System/Network > Date/Time**.

- **Mode:** Manual.
- **Format:** Set the date format.
- **Date:** Set the date.
- **Time:** Set the time.

### Configure the Local Interface

From the main menu, select **Config > System/Network > Local Interface**.

- **Contrast:** Set the screen contrast for the LCD. Select from 0 (high contrast) to 7 (low contrast).
- **Key Click:** Choose On for an audible click whenever you press a navigation key. Choose Off to disable the audible key click.
- **Beeper:** Select High, Medium, Low, or Off to adjust the volume of the audible beeper and the key click.
- **Check Log Light:** Determine what system alarms will cause the Check Log LED on the display to be illuminated: Info, Warning, Critical, or Disable.

### Configure the Network Address

From the main menu, select **Config > System/Network > Network Address**.

The following values are set by the Data Center Expert during initial configuration:

- **Mode:** How the IP settings are assigned: Fixed IP Addr, DHCP Only, or BOOTP only.
- **IP:** The System IP address, which the domain name server translates into a domain name.
- **SM:** The subnet mask, which identifies the sub-network on which the InfraStruxure PDU operates.
- **GW:** The Gateway address. This is the physical address of the InfraStruxure PDU, expressed as a 48-bit hexadecimal number.

## Configure the System ID

The **System ID** screen can be used to identify your InfraStruxure PDU.

### Configure the Device Name

From the main menu, select **Config > System ID > Device name**. Set a unique name for your InfraStruxure PDU.

### Configure the Product Contact

From the main menu, select **Config > System ID > Product Contact**. Identify the person to notify concerning questions or problems with regard to the product.

### Configure the Product Location

From the main menu, select **Config > System ID > Product Location**. Name the physical location of the product in your data center.

## Configure the Network Management Interface

### Connect the InfraStruxure PDU to the Network or to StruxureWare Data Center Expert

1. Connect a Cat-5 network cable to the surge-protected Ethernet port on the PDU user connection plate. Make connections from inside the PDU cabinet, and route wires through the knockout provided on the user connection plate. For easier access, you can also remove the user connection plate and make the connections: Loosen the two captive screws and lift up the user connection plate. Make sure that you do not disconnect any existing connections.

#### View of PDU Roof

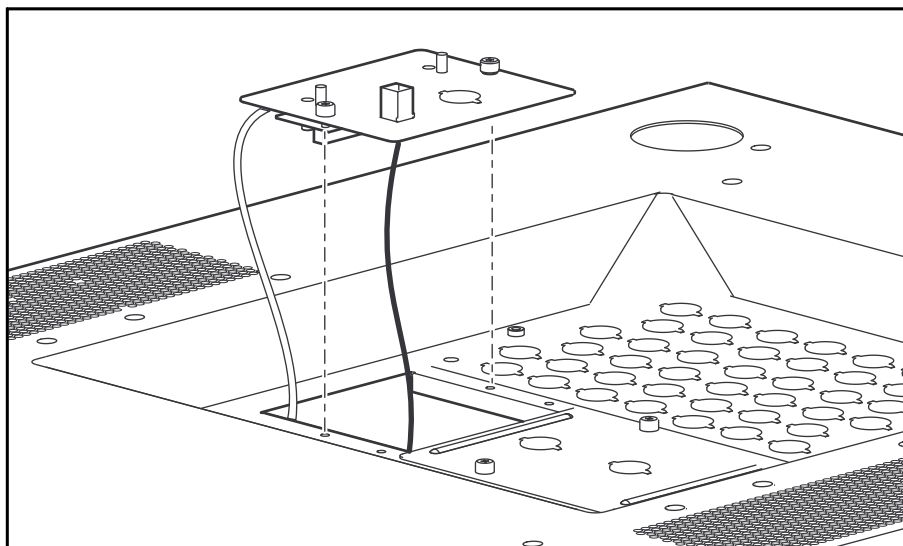

2. Run the connected Cat-5 network cable through the knockout in the user connection plate to the StruxureWare Data Center Expert Switch or to your network connection.
3. Use the StruxureWare Data Center Expert documentation to configure StruxureWare, or *TCP/IP Configuration Overview, page 17* to configure the TCP/IP settings of the InfraStruxure PDU.



## TCP/IP Configuration Overview

You must configure the following TCP/IP settings before the InfraStruxure PDU can operate on a network:

- IP address of the InfraStruxure PDU
- Subnet mask
- Default gateway If a default gateway is unavailable, use the IP address of a computer that is located on the same subnet as the InfraStruxure PDU and that is usually running. The InfraStruxure PDU uses the default gateway to test the network when traffic is very light. See 40 and 60 kW InfraStruxure Power Distribution Unit User Manual for more information.

**NOTE:** Do not use the loopback address as the default gateway address for the Network Management Card. You will lose communication with the equipment. Doing so will disable the card and require you to reset TCP/IP settings to their defaults using a local serial login.

## TCP/IP Configuration Methods

Use one of the following methods to define the TCP/IP settings needed by the InfraStruxure PDU:

- Device IP Configuration Wizard: *Device IP Configuration Wizard, page 17.*
- BOOTP or DHCP server: *BOOTP and DHCP Configuration, page 18.*
- Local computer: *Configure TCP/IP Setting in the Command Line Interface with Local Access, page 19.*
- Networked computer: *Configure TCP/IP Setting in the Command Line Interface with Remote Access, page 20.*

## Device IP Configuration Wizard

The Device IP Configuration Wizard configures the IP address, subnet mask, and default gateway of one or more NMCs. You can use the Wizard in either of the following ways:

- Remotely over your TCP/IP network to discover and configure unconfigured NMCs on the same network segment as the computer running the Wizard.
- Through a direct connection from a serial port of your computer to the PDU to configure or reconfigure it.

You can use the Device IP Configuration Wizard on Microsoft® Windows® 2000, Windows Server® 2003, Windows Server 2012, and on 32- and 64-bit versions of Windows XP, Windows Vista, Windows 2008, Windows 7, Windows 8, and Windows 10 Operating systems. The Device IP configuration Wizard supports cards that have firmware version 3.0.x or higher and is for IPv4 only.

To configure one or more InfraStruxure PDUs by exporting configuration settings from a configured PDU, see the 40 and 60 kW InfraStruxure Power Distribution Unit User Manual on [www.apc.com](http://www.apc.com).

1. Go to [www.apc.com/tools/download](http://www.apc.com/tools/download).
2. Download the latest version of the Device IP Configuration Wizard.
3. Run the executable file in the folder in which it was downloaded.
4. Launch the Wizard.

**NOTE:** Most software firewalls must be temporarily disabled for the Wizard to discover unconfigured PDUs.

## BOOTP and DHCP Configuration

In the web interface, the TCP/IP options are defined under the Configuration tab, in the Network menu. The possible settings are Manual, BOOTP, and DHCP (the default setting). A user configuration (INI) file can function as a BOOTP or DHCP boot file.

**NOTE:** NOTE: The DHCP and BOOTP settings assume that a properly configured DHCP or BOOTP server is available to provide TCP/IP settings to the Rack ATS. If these servers are unavailable, *Device IP Configuration Wizard, page 17, Configure TCP/IP Setting in the Command Line Interface with Local Access, page 19, or Configure TCP/IP Setting in the Command Line Interface with Remote Access, page 20* to configure the needed TCP/IP settings.

1. **BOOTP.** You can use an RFC951-compliant BOOTP server to configure the TCP/IP settings for the InfraStruxure PDU.
  - a. In the BOOTPTAB file of the BOOTP server, enter the InfraStruxure PDU's MAC and IP addresses, the subnet mask and default gateway settings, and an optional Bootup file name. For the MAC address, look on the Quality Assurance slip included with the InfraStruxure PDU.
  - b. When the InfraStruxure PDU reboots, the BOOTP server provides it with the TCP/IP settings.
    - If you specified a bootup file name, the InfraStruxure PDU attempts to transfer that file from the BOOTP server using TFTP or FTP. The InfraStruxure PDU assumes all settings specified in the bootup file.
    - If you did not specify a bootup file name, the InfraStruxure PDU can be configured remotely by using Telnet or by using the Web interface: User Name is apc by default. To create the bootup file, see your BOOTP server documentation.
2. **DHCP.** You can use a RFC2131/RFC2132-compliant DHCP server to configure the TCP/IP settings for the InfraStruxure PDU.
  - a. An InfraStruxure PDU sends out a DHCP request that uses the following to identify itself:
    - A Vendor Class Identifier (APC by default)
    - A Client Identifier (by default, the InfraStruxure PDU's MAC address value)
    - A User Class Identifier (by default, the identification of the InfraStruxure PDU's application firmware)
    - A Host Name (by default, apcXXYYZZ with XXYYZZ being the last six digits of the PDU serial number). This is known as DHCP Option 12.
  - b. A properly configured DHCP server responds with a DHCP offer that includes all of the settings that the InfraStruxure PDU needs for network communication. The DHCP offer also includes the Vendor Specific Information option (DHCP option 43). The InfraStruxure PDU can be configured to require the APC cookie in DHCP offers in the Vendor Specific Information option using the following hexadecimal format (the PDU does not require this cookie by default):
 

```
Option 43 = 01 04 31 41 50 43
```

 where:
    - the first byte (01) is the code
    - the second byte (04) is the length
    - the remaining bytes (31 41 50 43) are the APC cookies

See your DHCP server documentation to add code to the Vendor Specific Information option. To disable the APC cookie requirement, see the 40 and 60 kW InfraStruxure Power Distribution Unit User Manual.

## Configure TCP/IP Setting in the Command Line Interface with Local Access

You can use a local computer that connects to the InfraStruxure PDU through the console port on the InfraStruxure PDU monitoring unit to access the Command Line Interface (CLI).

1. Select a serial port at the local computer, and disable any service that uses that port.
2. Use the configuration cable (part number 940-0103) to connect the selected port to the console port on the InfraStruxure PDU monitoring unit.
3. Run a terminal program (such as HyperTerminal®) on your computer and configure the selected port for 9600 bps, 8 data bits, no parity, 1 stop bit, and no flow control, and save the changes.
4. Press ENTER to display the **User Name** prompt.
5. Use **apc** for the **User Name**.
6. Contact your network administrator to obtain the IP address, subnet mask, and default gateway for the PDU.
7. Use these three commands to configure network settings. (Text in bold indicates a variable.):

```
tcpip -i yourIPAddress  
tcpip -s yourSubnetMask  
tcpip -g yourDefaultGateway
```

For each variable, type a numeric value that has the format xxx.xxx.xxx.xxx. For example, to set a system IP address of 156.205.14.141, type the following command and press ENTER:

```
tcpip -i 156.205.14.141
```

8. Type exit, and then press ENTER. The PDU restarts to apply the changes.  
**NOTE:** If you disconnected a cable during this procedure, reconnect that cable and restart the associated service.

## Configure TCP/IP Setting in the Command Line Interface with Remote Access

From any computer on the same subnet as the InfraStruxure PDU, you can use ARP and Ping to assign an IP address to an InfraStruxure PDU, and then use Telnet to access that InfraStruxure PDU's CLI and configure the needed TCP/IP settings.

**NOTE:** After an InfraStruxure PDU has its IP address configured, you can use Telnet, without first using ARP and Ping, to access that InfraStruxure PDU.

1. Use ARP to define an IP address for the InfraStruxure PDU, and use the InfraStruxure PDU's MAC address in the ARP command. (For the MAC address, look on the Quality Assurance slip included with the InfraStruxure PDU.) For example, to define an IP address of 156.205.14.141 for an InfraStruxure PDU that has a MAC address of 00 c0 b7 63 9f 67, use one of the following commands:
  - Windows command format:  

```
arp -s 156.205.14.141 00-c0-b7-63-9f-67
```
  - LINUX command format:  

```
arp -s 156.205.14.141 00:c0:b7:63:9f:67
```
2. Use Ping with a size of 113 bytes to assign the IP address defined by the ARP command. For the IP address defined in step 1, use one of the following Ping commands:
  - Windows command format:  

```
ping 156.205.14.141 -l 113
```
  - LINUX command format:  

```
ping 156.205.14.141 -s 113
```
3. Use Telnet to access the InfraStruxure PDU at its newly assigned IP address. For example:

```
telnet 156.205.14.141
```

4. Use **apc** for the **User Name**.

5. Contact your network administrator to obtain the IP address, subnet mask, and default gateway for the PDU.

6. Use these three commands to configure network settings. (Text in bold indicates a variable.):

```
tcpip -i yourIPAddress  
tcpip -s yourSubnetMask  
tcpip -g yourDefaultGateway
```

For each variable, type a numeric value that has the format xxx.xxx.xxx.xxx. For example, to set a system IP address of 156.205.14.141, type the following command and press ENTER:

```
tcpip -i 156.205.14.141
```

7. Type exit, and then press ENTER. The PDU restarts to apply the changes.

**NOTE:** If you disconnected a cable during this procedure, reconnect that cable and restart the associated service.

## Configure the Alarm Setup

1. From the main menu, select **Alarms > Alarm Setup**.
2. Set up the **Loading Limits** in amps and as a percentage of full load:
  - a. **Out High**: Set the upper limit for output current.
  - b. **Out Low**: Set the lower limit for output current.
  - c. **Out Neut**: Set the upper limit for current on the neutral wire for the output phases.
3. Set up the **Voltage Limits** as a percentage under or over the rated voltage:
  - a. **Input**: Set the allowed range for input voltage.
  - b. **Output**: Set the allowed range for output voltage.
4. Set up the **Other Limits**:
  - a. **Frequency**: Set the frequency variation in Hertz that is acceptable for the output current.
5. Set all the loading limits or all the voltage limits simultaneously as a percentage of full load with the **Global Alarm Config** :
  - a. **Load Limits**: Set the same percentage for the upper limit for output current, the lower limit for output current, and the upper limit for current on the neutral wire for the output phases. (Use the **Loading Limits** option to set these thresholds individually.)
  - b. **Volt Limits**: Set the same percentage for the high and low thresholds for input and output voltage. (Use the **Voltage Limits** option to set these thresholds individually.)
6. Select **Apply Now** and **YES** to implement the changes.

# Operation

## Perform a Total Power Off

1. On the main power source feeding the PDU: Set the main breaker to the OFF or Locked Out position. If the PDU has two power sources, set the main breaker on each power source to the OFF or Locked Out position.

### Main Power Source Breaker

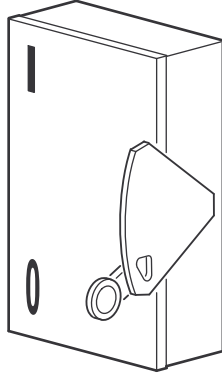

2. On the PDU: Set the main input switch to the OFF position.

### PDU Main Input Switch

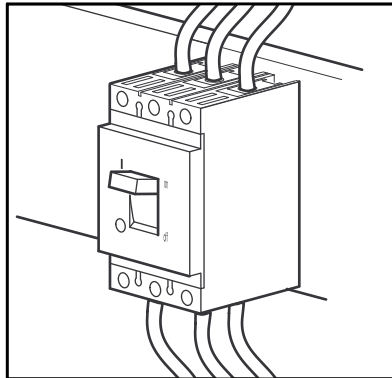

3. On a PDU with a transformer: Set the Main Output breaker to the OFF position.

### PDU Main Output Breaker

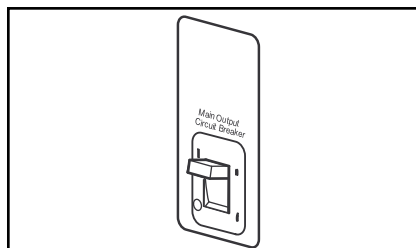

## Restart the System

**NOTE:** This procedure instructs on how to restart a system that has already been installed. For initial start-up instructions, refer to the Installation and Start-Up manual included with your PDU.

1. On the main power source feeding the PDU: Set the main breaker to the ON position. If the PDU has two power sources, set the main breaker on each power source to the ON position.

### Main Power Source Breaker

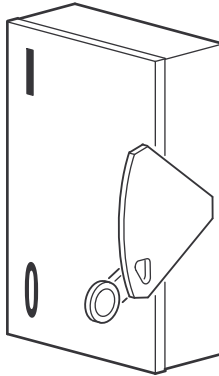

2. On the PDU: Set the main input switch to the ON position.

### PDU Main Input Switch

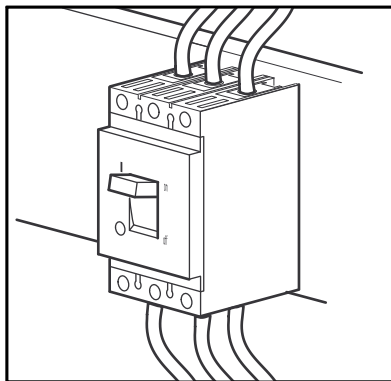

3. On a PDU with transformer: Set the Main Output breaker to the ON position to apply power to both PDU distribution panels.

### PDU Main Output Breaker

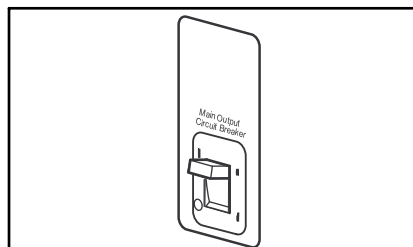

4. On the PDU: Set the distribution panel breakers to the ON position to apply power to the PDU power cables and connected equipment.

#### PDU Distribution Panel Breakers

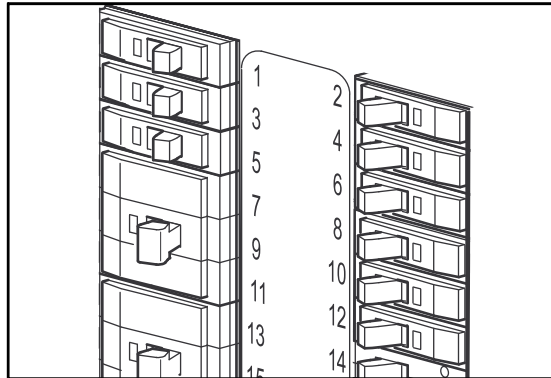



## Access a Network Management Interface on a Configured InfraStruxure PDU

**NOTE:** Disregard the procedures in this section if you have the StruxureWare® Data Center Expert as part of your system. See *Configure the Network Management Interface, page 16* and the StruxureWare Data Center Expert's Installation and Quick-Start manual for access information.

### Web interface

To access the web interface on Windows® operating systems, use Microsoft® Internet Explorer® (IE) 8.x or higher (with compatibility view turned on), or the latest release of Microsoft Edge®. To access the web interface on any operating system, use the latest releases of Mozilla®, Firefox®, or Google Chrome®. Other commonly available browsers also may work but have not been fully tested by Schneider Electric. The InfraStruxure PDU cannot work with a proxy server. Before accessing the Web interface of the PDU, do one of the following:

- Configure the browser to disable the use of a proxy server for your PDU.
- Configure the proxy server so that it does not proxy the specific IP address of your PDU.

To use the Web browser to configure InfraStruxure PDU options or to view the event log, you can use either of the following:

- The HTTP protocol which provides authentication by user name and password but no encryption.
- The more secure HTTPS protocol, which provides extra security through Secure Sockets Layer (SSL)/Transport Layer Security (TLS) and encrypts user names, passwords, and data being transmitted. It also provides authentication of Network Management Cards by means of digital certificates.

To access the Web interface and configure the security of your device on the network:

1. Address the InfraStruxure PDU by its IP address or DNS name (if configured).
2. Enter the user name and password.
3. Select and configure the type of security you want. (This option is available only for Administrators).

**NOTE:** See the 40 and 60 kW InfraStruxure Power Distribution Unit User Manual or the Security Handbook: Network Enabled Devices, AOS v6.4.x for information on choosing and setting up your network security.

### Telnet and SSH

You can access the Command Line Interface (CLI) through Telnet or Secure SHell (SSH), depending on which is enabled. (A Super User or Administrator can enable these access methods.)

**Telnet for basic access.** Telnet provides the basic security of authentication by user name and password, but not the high-security benefits of encryption. To use Telnet to access an InfraStruxure PDU's CLI from any computer on the same subnet:

1. At a command prompt, use the following command line, and press ENTER:  

```
telnet address
```

As  
address  
, use the InfraStruxure PDU's IP address or DNS name (if configured).
2. Enter the user name and password.

**SSH for high-security access.** If you use the high security of SSL/TLS for the Web interface, use Secure SHell (SSH) for access to the CLI. SSH encrypts user names, passwords, and transmitted data. The interface, user accounts, and user access rights are the same whether you access the CLI through SSH or Telnet, but to use SSH, you must first configure SSH and have an SSH client program

installed on your computer. See the 40 and 60 kW InfraStruxure Power Distribution Unit User Manual for more information on configuring and using SSH.

## SNMP

After you add the PowerNet™ MIB to a standard SNMP MIB browser, you can use that browser for SNMP access to the InfraStruxure PDU. When using StruxureWare to manage a unit on the network, you must have the same version of SNMP (version 1 or version 3) enabled in the PDU interface and in StruxureWare Data Center Expert. Read access will allow StruxureWare to receive traps from the InfraStruxure PDU, but Write access is required while you use the interface to set StruxureWare as a trap receiver. See the 40 and 60 kW InfraStruxure Power Distribution Unit User Manual for more information about using SNMP.

**NOTE:** If you enable SSL/TLS and SSH for their high-security authentication and encryption, disable SNMP. Allowing SNMP access to the InfraStruxure PDU compromises the high security you implement by choosing SSL/TLS and SSH. To disable SNMP, you must be a Super User or Administrator.

## FTP and SCP

You can use FTP or Secure CoPy (SCP) to transfer new firmware to the InfraStruxure PDU, or to access a copy of the InfraStruxure PDU's event logs. SCP provides the higher security of encrypted data transmission and is enabled automatically when you enable SSH.

**NOTE:** If you enable SSL/TLS and SSH for their high-security authentication and encryption, disable FTP. Allowing file transfer to the InfraStruxure PDU through FTP compromises the high security you implement by choosing SSL/TLS and SSH. To disable FTP, you must be a Super User or Administrator; see the 40 and 60 kW InfraStruxure Power Distribution Unit User Manual.

To access the InfraStruxure PDU through FTP or SCP, the default user name is **apc** for an Administrator, or **device** for a Device Manager. In the CLI, use the IP address of the unit. See the 40 and 60 kW InfraStruxure Power Distribution Unit User Manual to use FTP or SCP to retrieve log files from the InfraStruxure PDU or to transfer firmware files to the InfraStruxure PDU.

## View the PDU Status Information

### Load-Meter Screen

From the **Load-Meter** screen, you can select the following items:

**Total Load by Phase:** The load supported by each phase in kVA, in RMS current (Irms), and as a percentage of the maximum allowable load (%LD).

**Total Load Summary:** For the total load supported:

- **kW:** The power provided, in kilowatts
- **kVA:** The actual power drawn by the load, in kilovolt-amperes
- **Freq:** The frequency
- **PF:** The power factor (kW/kVA), which affects the power available to the load
- **%LD:** The load as a percentage of the maximum allowable load

**Power Factor :** For each phase:

- **kVA:** The actual power drawn by the load, in kilovolt-amperes
- **kW:** The power, in kilowatts provided by the phase
- **PF:** The power factor (kW/kVA), which affects the power available to the load

### Volt-Meter Screen

From the **Volt-Meter** screen, you can select the following items:

**Output Voltage:** Displays each phase-to-phase output voltage (e.g., **L1-2** for phase L1 to phase L2) and each phase-to-neutral output voltage (e.g., **L1** for phase L1 to neutral).

**Input Voltage:** Displays each phase-to-phase input voltage (e.g., **L1-2** for phase L1 to L2), or, if your service transformer is a wye transformer, each phase-to-neutral input voltage (e.g., **L1** for phase L1 to neutral).

### Contacts Screen

**Overview:** The PDU can monitor external contact closure events. Possible applications include the following:

- Magnetic contact switches
- Window foil
- Tamper switches
- Heat detectors
- Water sensors
- Pressure sensors
- Building smoke and fire detection systems

You can set input contacts to cause alarm conditions based on their current state and a user-defined normal state. Relay outputs can map internal alarms and events to outside devices. Use the **Contacts** screen to display and configure information about input contacts and relay outputs.

**Input Contacts:** Scroll through the list to display information about each of the installed input contacts. For example, **02of04** displays information about the second of four installed input contacts.

- **Name** –The name of this input contact (Maximum: 14 alphanumeric characters).
- **Normal** – The normal position of this input contact, either **Open** or **Closed**.
- **Status** –The position of this input contact. If the position is not the normal position, an alarm condition occurs.

**Relay Outputs:** Scroll through the list to display information about each of the installed relay outputs. For example, **04of04** displays information about the fourth of the four available relay outputs.

- **Name** – The name of this relay output (Maximum: 14 alphanumeric characters).
- **Normal** –The normal position of this relay output, either **Open** or **Closed**.
- **Status** –The position of this relay output.

**Alarm Relay Map:** Configure the relay outputs, using the Alarm Relay Map. Each Alarm Map corresponds to a relay output. For example, Alarm Map **01of04** corresponds to the first of four relay outputs. The second line, in brackets [ ], lists the items that you have selected to map to the selected relay. The third line allows you to select the alarms to which you want to map the relay:

```
Alarm Map: 01 of 04
[Vo, By, C4]
Map: Input Voltage
Apply Now
```

- **Any Load (L)** – Maps to over- or under-current alarms for circuit breaker panels and branch circuits.
- **Overload (O)** – Maps to over-current alarms for circuit breaker panels, branch circuits, and SYSGND.
- **Input Voltage (Vi)** – Maps to any input voltage alarm.
- **Output Voltage (Vo)** – Maps to any output voltage alarm.
- **PDU in Bypass (By)** – Not used by this PDU model.
- **Any Breaker (Br)** – Not used by this PDU model.
- **Contacts 1-4 (C1 ,C2 ,C3 ,C4)** – Maps to the input contact alarms.

Before exiting the screen, to save your changes, select the **Apply Now** option on the bottom line of the screen.

## Breakers Screen

Use the **Breakers** screen to view the status of the system and PDU circuit breakers.

**Main Input:** Reports the status of the PDU Main Input Switch (**Open** or **Closed**). Under normal operation, this switch is **Closed**.

## Panel Screen

**Branch Ckt Loading.** You can display **Branch Ckt Loading** (Branch Circuit Loading) status if the option to measure current at the distribution circuit breakers is installed. You can view data for each individual panel position on the distribution panel. To view status of a panel position, select the range that includes the position:

```
Branch Ckt Loading
Select Range:
[01..41] [02..42]
[43..83] [44..84]
```

The top line of selections on the screen applies to the top distribution circuit breaker panel on the PDU. The bottom line of selections applies to the bottom distribution circuit breaker panel on the PDU. The panel position numbers on the screen correspond to the numbers on the distribution panel. (Odd numbers are on the left; even numbers are on the right.)

After you have selected the correct range, press the arrow keys to scroll through the list of circuit breakers in the selected range. Poles that are tied together will be shown on the same screen.

```
Ckt:↓ 03of21 Irms %LD
05: 20A 11.3 56.5
```

In the example above, the screen shows the third circuit breaker of 21 circuit breakers in the selected range. This is a single-pole circuit breaker, occupying panel position 05. The circuit breaker is rated at 20 amps. The following data are displayed for each pole:

- **Irms**: Measured root mean square (RMS) current of the pole position.
- **%LD**: Present load as a percentage of rated load of the panel position.

**Branch Ckt Limits.** Available only if the option to measure individual currents is installed, **Branch Ckt Limits** (Branch Circuit Limits) accesses a scrollable list of the circuit breakers in the panel. For each circuit breaker, the screen displays, in the **Loading** column, the current on each panel position as a percentage of the rated current. In the **Load Alarm** column, you can configure the high and low thresholds for the circuit breaker as a percentage of its rated current. For example, if you set 80% as the high threshold for a single-pole 20-amp circuit breaker, an alarm condition occurs if the current reaches 16 amps.

**Panel Configuration.** Configure the branch metering settings for each circuit breaker on the distribution panel, or configure both panels simultaneously. To configure a circuit breaker, select the range that includes the circuit breaker. The top line of selections on the screen apply to the top distribution circuit breaker panel on the PDU. The bottom line of selections apply to the bottom distribution circuit breaker panel on the PDU. The panel position numbers on the screen correspond to the numbers on the distribution panel. (Odd numbers are on the left; even numbers are on the right.) After you have selected the correct range, configure the settings for each circuit breaker in the range.

```
Panel Configuration
Select Range:
[01..41] [02..42]
```

**Pos:** The panel positions in the selected range.

**Breaker:** Two configurable items:

- The circuit breaker rating, in amps.
- The circuit breaker tie indicator – define the number of panel positions tied (i. e., associated). You can associate positions with circuit breakers, which enables you to view status about each circuit breaker and receive alarm notification when any of a circuit breaker's poles are above or below the configured branch circuit limit. You can also tie together panel positions that are logically associated. For example, you can tie together panel positions for three separate circuit breakers that are connected to the same PDU power cord and that feed power to the same equipment enclosure.

To configure the values on this screen:

1. From the first column, use the arrow keys to scroll up or down to the pole position you want to configure.
2. Press the ENTER key to move to the item you want to configure in the third column (the circuit breaker rating or the circuit breaker tie indicator).
3. Scroll again to select the value you want for the circuit breaker rating or the circuit breaker tie indicator. To associate one panel position with the next position in the list, choose the + character as the tie indicator immediately following the circuit breaker rating. To indicate that the position is not tied to (associated with) the next panel position in the list, choose the ] character as the tie indicator immediately following the circuit breaker rating. When you change the + or ] character that follows the circuit breaker rating in one row, the + or [ character before the circuit breaker rating in the next row also changes to indicate the changed association between the panel positions.

For example, this screen shows three, single-pole, 20 A, tied circuit breakers occupying positions 08, 10, and 12 on the top right distribution panel.

```
Pos      Breaker
08      [ 20A +
10      + 20A +
12      + 20A ]
```

## View the Electrical Configuration

The **Electrical Configuration** screen displays information about the electrical service that provides input to the InfraStruxure PDU. All of the values displayed on this screen are set at the factory. Use this information when viewing and setting alarms. See *Configure the Alarm Setup*, page 21.

### View the Input Config

From the main menu, select **Config > Electrical Configuration > Input Config**.

- **Main Input:** The voltage from the building's electrical service coming into the PDU Main Input switch.
  - **3W:** 3-phase Delta, measured line-to-line
  - **4W:** 3-phase Wye, measured line-to-neutral
- **Transformer:** Indicates whether the InfraStruxure PDU has a transformer.
- **Fuses:** Indicates whether the PDU has fuses protecting the SCRs in the UPS. The fuses are present only on single-fed PDUs without a transformer.
- **Fans:** Indicates whether cooling fans are installed in the PDU.

### View the Output Config

From the main menu, select **Config > Electrical Configuration > Output Config**.

- **Panel Voltage:** The nominal voltage of the distribution panels supplying power to the load equipment. (This is measured line-to-neutral.)
- **Panel Breaker:** The rating, in amps, of the circuit breaker feeding the distribution panels.
- **Frequency:** Set the output frequency to 50 or 60 Hz.
- **Cross Tie Out:** Indicates whether the PDU has a cross-tie output breaker.

### View the Other Config Items

From the main menu, select **Config > Electrical Configuration > Other Config Items**.

- **Load Test Port:** Indicates whether the PDU has a load test port installed.
- **Max Power:** Maximum power of your InfraStruxure PDU (40 kW or 80 kW).
- **Subfeed Port:** Indicates the port where the Subfeed is set.

# Customization

## Multi-Branch Cordset Adapters

Schneider Electric offers two multi-branch cordset adapters. The adapters connect to a multi-branch power cord (whip) on the InfraStruxure PDU and distribute three separate branches to Rack PDUs in your equipment racks. See the table below for compatible Rack PDUs.

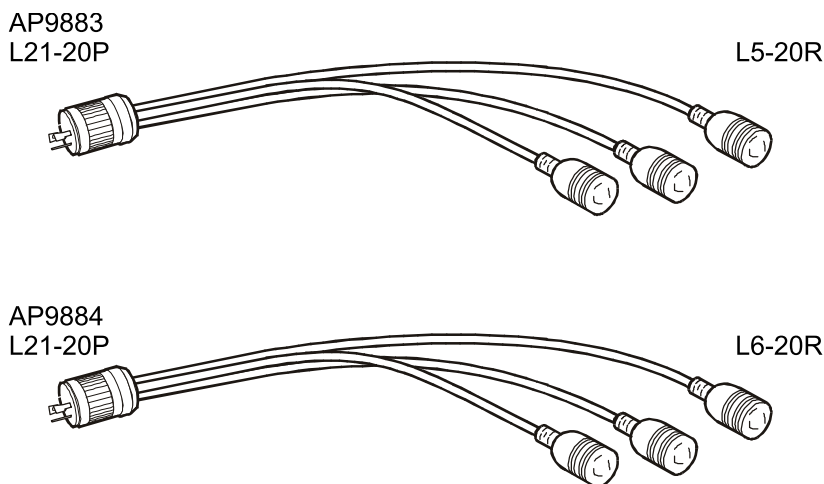

Compatible Schneider Electric 120 V PDUs			
Commercial reference	Plug	Outlets	Manageable
AP7530	L5-20P	(24) NEMA 5-20R	No
AP9551	L5-20P	(14) NEMA 5-15R	No
AP9563	L5-20P	(10) NEMA 5-20R	No
AP9564	L5-20P	(10) NEMA 5-20R	No
AP7830	L5-20P	(24) NEMA 5-20R	Yes
AP7901	L5-20P	(24) NEMA 5-20R	Yes
AP7930	L5-20P	(24) NEMA 5-15R	Yes
AP7930J	L5-20P	(24) NEMA 5-15R	Yes
AP9510520	L5-20P	(2) NEMA L5-20R	No
SU042X163	L5-20P	(1) NEMA L5-20R	No

Compatible Schneider Electric 208 V PDUs			
Commercial reference	Plug	Outlets	Manageable
AP7540	L6-20P	(20) IEC 320 C13 (4) IEC 320 C19	No
AP7840	L6-20P	(20) IEC 320 C13 (4) IEC 320 C19	Yes
AP7940	L6-20P	(21) IEC 320 C13 (3) IEC 320 C19	Yes
AP9510L620	L6-20P	(1) NEMA L6-20R	Yes
SU045X163	L6-20P	(1) NEMA L6-30R	No

## PDU Orderable Part List

Various circuit breakers and power cables offered by Schneider Electric are compatible with 60 kW InfraStruxure PDUs.

### Circuit Breakers

Commercial reference	Description
PD1P20ABBSD	single-pole, 20-amp breaker
PD1P50ABBSD	single-pole, 50-amp breaker
PD2P20ABBSD	two-pole, 20-amp breaker
PD2P30ABBSD	two-pole, 30-amp breaker
PD3P20ABBSD	three-pole, 20-amp breaker
PD3P80ABBSD	three-pole, 80-amp breaker

### 20 A 3-Wire Power Cables

Commercial reference	Description
PDW5L21-20R	5-foot power cable
PDW7L21-20R	7-foot power cable
PDW9L21-20R	9-foot power cable
PDW11L21-20R	11-foot power cable
PDW13L21-20R	13-foot power cable
PDW15L21-20R	15-foot power cable
PDW17L21-20R	17-foot power cable
PDW19L21-20R	19-foot power cable
PDW21L21-20R	21-foot power cable
PDW23L21-20R	23-foot power cable
PDW25L21-20R	25-foot power cable
PDW27L21-20R	27-foot power cable
PDW29L21-20R	29-foot power cable
PDW31L21-20R	31-foot power cable
PDW33L21-20R	33-foot power cable
PDW35L21-20R	35-foot power cable
PDW37L21-20R	37-foot power cable
PDW39L21-20R	39-foot power cable
PDW41L21-20R	41-foot power cable
PDW43L21-20R	43-foot power cable
PDW45L21-20R	45-foot power cable
PDW47L21-20R	47-foot power cable
PDW49L21-20R	49-foot power cable
PDW51L21-20R	51-foot power cable
PDW53L21-20R	53-foot power cable
PDW55L21-20R	55-foot power cable
PDW57L21-20R	57-foot power cable
PDW59L21-20R	59-foot power cable



**20 A 3-Wire Power Cables (Continued)**

Commercial reference	Description
PDW61L21-20R	61-foot power cable
PDW63L21-20R	63-foot power cable

**30 A 3-Wire Power Cables**

Commercial reference	Description
PDW7L6-30C	7-foot power cable
PDW9L6-30C	9-foot power cable
PDW11L6-30C	11-foot power cable
PDW13L6-30C	13-foot power cable
PDW15L6-30C	15-foot power cable
PDW17L6-30C	17-foot power cable
PDW19L6-30C	19-foot power cable
PDW21L6-30C	21-foot power cable
PDW23L6-30C	23-foot power cable
PDW25L6-30C	25-foot power cable
PDW27L6-30C	27-foot power cable
PDW29L6-30C	29-foot power cable
PDW31L6-30C	31-foot power cable
PDW33L6-30C	33-foot power cable
PDW35L6-30C	35-foot power cable
PDW37L6-30C	37-foot power cable
PDW39L6-30C	39-foot power cable
PDW41L6-30C	41-foot power cable
PDW43L6-30C	43-foot power cable
PDW45L6-30C	45-foot power cable
PDW47L6-30C	47-foot power cable
PDW49L6-30C	49-foot power cable
PDW51L6-30C	51-foot power cable
PDW53L6-30C	53-foot power cable
PDW55L6-30C	55-foot power cable
PDW57L6-30C	57-foot power cable
PDW59L6-30C	59-foot power cable
PDW61L6-30C	61-foot power cable

# Maintenance

## DANGER

### HAZARD OF ELECTRIC SHOCK, EXPLOSION, OR ARC FLASH

- Electrical equipment must be installed, operated, serviced, and maintained only by qualified personnel.
- Turn off all power supplying the equipment and perform appropriate Lockout/Tagout procedure before servicing the equipment.
- The PDU must be installed in accordance with the National Electrical Code or the Canadian Electrical Code and all applicable local codes.
- Wear appropriate personal protection equipment (PPE) when performing maintenance on this PDU.

**Failure to follow these instructions will result in death or serious injury.**

## Download Firmware Updates

From the main menu, select **Config > Firmware Updates** to download updated firmware to the InfraStruxure PDU.

## Reset to Factory Defaults

From the main menu, select **Config > Factory Defaults** to reset all InfraStruxure PDU settings to their factory default values.

## View the Manufacturer Data

From the main menu, select **Config > Manufacturer Data** to display a scrollable list containing information about the InfraStruxure PDU. This information is useful when requesting service or product updates. The following information is displayed:

- **Manufacturer Name**
- **Date of Manufacture**
- **Date of Calibration**
- **Hardware Revision**
- **Firmware Revision** (for PDU monitoring and metering)
- **Serial Number**
- **Model Number**

## Upgrade the PDU Monitor Firmware

You can download available PDU monitor processor upgrades through the PDU display interface. The most obvious indication that a firmware upgrade is necessary occurs when the Network Management Card and the monitor processor stop communicating. This lack of communication causes the PDU's data to no longer be accessible through the display interface and a **SysData Mismatch** alarm to occur. When this alarm occurs, perform the following steps to upgrade the PDU monitor processor firmware:

1. Upgrade the PDU Network Management Card. For instructions on how to upgrade the PDU's Network Management Card, refer to the 40 and 60 kW InfraStruxure Power Distribution Unit User Manual on [www.apc.com](http://www.apc.com).
2. At the PDU display interface, select Config, and then Firmware Updates. You will receive the following screen:

```
Upgrade from X.XX  
To X.XX  
Preass a key.
```

Press any key to download the upgrade.

**NOTE:** If you do not receive the **SysData Mismatch** alarm, but want to check for available firmware upgrades, you can do so by performing step 2 in the procedure above.

## Recover From a Lost Network Management Interface Password

1. Select a serial port at the local computer, and disable any service that uses that port.
2. Connect the serial cable (Schneider Electric part number 940-0103) to the selected port on the computer and to the console port on the PDU monitoring unit.
3. Run a terminal program (such as HyperTerminal®) on your computer and configure the selected port as follows:
  - 9600 bps
  - 8 data bits
  - no parity
  - 1 stop bit
  - no flow control
4. Press ENTER, repeatedly if necessary, to display the **User Name** prompt. If you are unable to display the **User Name** prompt, verify the following:
  - The serial port is not in use by another application.
  - The terminal settings are correct as specified in step 3.
  - The correct cable is being used as specified in step 2.
5. Press the reset button once. (Sometimes aligning a paper clip or similar to the pinhole reset button can be difficult. It is recommended to hold the paper clip or similar device towards the top of the reset button hole and press gently until the alignment is made). Wait 5-7 seconds (the status LED will be off while you wait). After 5-7 seconds, the status LED will flash rapidly while alternating between orange and green. Immediately press the reset button a second time while the status LED is flashing. This will cause the status LED to turn off and will temporarily reset both the user name and password to **apc**.
6. Press ENTER (repeatedly, if necessary) to redisplay the **User Name** prompt, then use the temporary user name and password **apc**. (If you take longer than 30 seconds to log on after the **User Name** prompt is redisplayed, you must repeat step 5 and log on again.)
7. Change the user name and password settings.
  - a. **For v5.X.X firmware only:** At the command line interface, use the following commands to change the user name and password settings, both of which are now temporarily **apc**:

```
user -an yourAdministratorName
user -ap yourAdministratorPassword
```

For example, to change the Administrator user name to Admin, type:

```
user -an Admin
```
  - b. **For v6.X.X firmware only:** At the command line interface, use the following commands to change the password setting for the Super User account, for which the user name is always **apc**, and the password is now temporarily **apc**:

```
user -n apc -pw yourNewSuperUserPassword
```

For example, to change the Super User's password to p@ssword, type:

```
user -n apc -pw p@ssword
```

The Super User account can be disabled for security reasons. In addition to possibly needing to reset its password, you may need to re-enable the account if no other administrative access is available or known. To do that, type:

```
user -n apc -e enable
```

The Super User can also reset the password for any account. For example, to change the password for user upsadmin to p@ssword, type:

```
user -n upsadmin -pw p@ssword
```

8. To log off, type quit exit or bye, and then press ENTER. Reconnect any serial cable you may have disconnected, and restart any service you may have disabled.

## Add a Breaker to the PDU

1. Snap and bolt the new circuit breaker into a position on the panel.

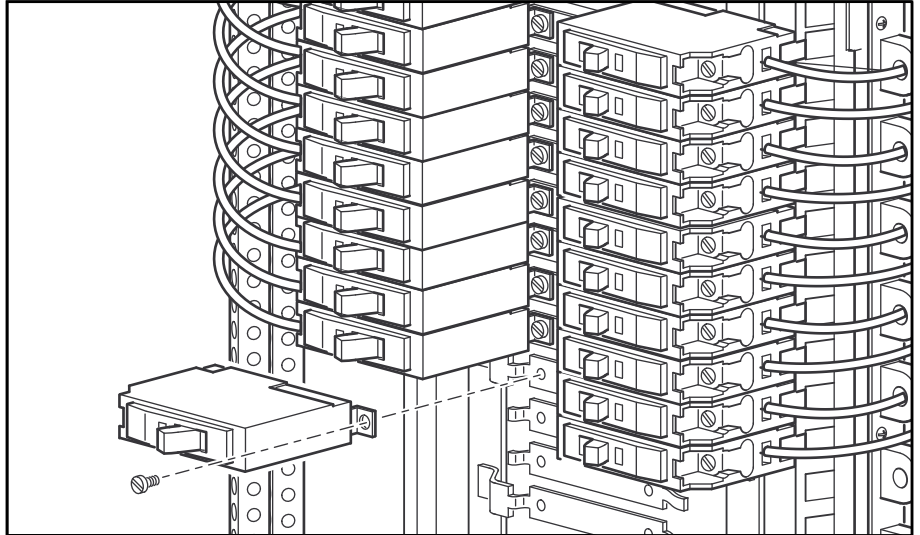

2. Remove the corresponding plastic blanking plate on the front panel of the PDU.

## Add a Power Cable to the PDU

**NOTE:** If you must install a 20 A or 30 A power cable in a knockout designed for a 50 A power cable, you must use reducing washers (included) to adjust the size of the hole.

**NOTE:** If you are adding a power cable that will attach to a circuit breaker on the bottom circuit breaker panel, use a non-conductive fish tape to feed the power cable down the rectangular wireway (chute) in the center of the PDU. This will allow you to easily access the bottom circuit breaker panel.

1. Install a strain-relief connector in any available knockout on the roof of the PDU.
2. Slide enough of the power cable through the strain-relief connector to reach the new circuit breaker.
3. Tighten the strain-relief connector.
4. At the front of the PDU, connect the power cord's individual wires:
  - a. If you have branch current monitoring installed, route the phase conductor through a current sensor. If it is a three-phase cable, route the L1, L2, and L3 wires through a current sensor.
  - b. Connect the L1, L2, and L3 wires to the circuit breaker(s). The illustration below shows single-pole breakers; however, you can also connect three-pole breakers.
  - c. Connect the neutral wire to the closest open termination point on the neutral bar (N).
  - d. Connect the ground wire to the closest open termination point on the ground bar (G).

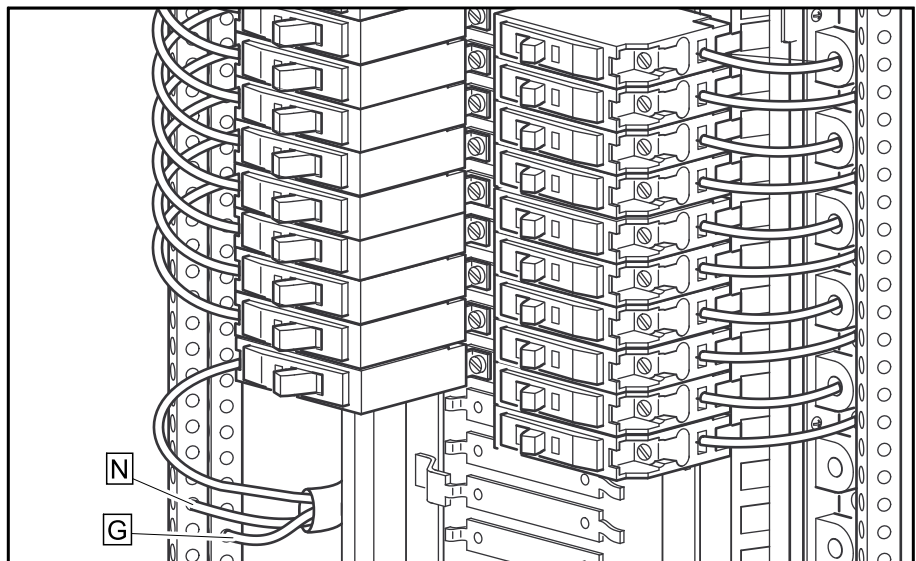

**NOTE:** You can configure your PDU through InfraStruxure Designer Build-Out Tool to use three, 20-A single-pole breakers to feed multi-circuit power cables supplying power to L-N loads. However, one 3-pole, 20 A breaker must be used with any power cable and Rack PDU the feeds L-L loads (NEC, NFPA 70).

## Test the EPO Switch

Schneider Electric offers an optional InfraStruxure Emergency Power Off (EPO) System (EPW9). Contact your Schneider Electric sales representative, or visit [www.apc.com](http://www.apc.com) for more information.

After a certified electrician has connected an EPO switch to the PDU monitoring unit by way of the user connection plate, you can test the switch to make sure it is wired and working properly. See detailed descriptions of the PDU monitoring unit in the Overview section of this manual.

- Place the arm/test rocker switch in the TEST position. The EPO state LEDs will be dark and the PDU display interface will show the following alarm (in addition to any other active alarms):

```
Active Alarm xxofxx
EPO Ready To Test
```

- Engage the EPO switch. (If your switch is momentary, engage it with one person watching the EPO state LEDs, and another at the EPO switch.)
- Observe the EPO LEDs. If the switch is wired and working properly, when the switch is engaged, both of the EPO state LEDs are red.

**NOTE:** Be sure that the EPO TRIPPED LED is not illuminated prior to placing the EPO arm/test rocker switch back to the ARMED position.

- If the test was successful, place the arm/test rocker switch back to the ARMED position. The PDU display interface will clear the EPO test mode alarm. If the test was not successful, see the troubleshooting chart. If the test was not successful, see the troubleshooting chart:

Event	Corrective action
Neither state LED was red when the EPO switch was engaged.	Check the wiring to your EPO switch. Check to make sure the EPO DIP switch configuration is correct for your switch (NO or NC).
Only one of the state LEDs was red when the EPO switch was engaged.	Check to make sure the EPO DIP switch configuration is correct for your switch (NO or NC) and test again. If the switch is configured correctly and both LEDs are not red after retesting, contact Schneider Electric.

- Repeat this test for each EPO switch installed.
- Ensure that the arm/test rocker switch is in the ARMED position on the monitoring unit upon completion of testing.

### ⚡ ⚠ DANGER

**HAZARD OF ELECTRIC SHOCK, EXPLOSION, OR ARC FLASH**

Hazardous voltage from the branch circuit must be isolated from the 24VAC, 24VDC, and contact closure. If you do not use a CL2 cable, route the EPO wiring in conduit that does not contain any branch circuit wiring.

**Failure to follow these instructions will result in death or serious injury.**

24VAC and 24VDC are considered Class 2 circuits as defined in Article 725 of the National Electrical Code (NFPA 70) and Section 16 of the Canadian Electrical Code (C22.1). A Class 2 circuit is a source having limited voltage and energy capacity as follows:

- If an Inherently Limited Power Source, voltage and energy are limited to less than 30VAC, less than 30VDC, and 8A.
- If not an Inherently Limited Power Source, voltage and energy are limited to less than 30VAC, less than 60VDC, 250VA, and the current is limited to 1000/V<sub>max</sub>. The fuse is limited to 5A if less than 20VAC or 20VDC, or 100/V<sub>maximum</sub> if less than 30VAC or 60VDC.

If you choose to use a 24VAC, 24VDC, or contact closure connection to the EPO, use one of the following UL-listed wire types:

- CL2 Class 2 cable for general purpose use.
- CL2P Plenum cable for use in ducts, plenums, and other space used for environmental air.
- CL2R Riser cable for use in a vertical run shaft from floor to floor.
- CL2X Limited Use cable for use in dwellings and for use in a raceway.
- For installation in Canada, the cable should be CSA Certified, type ELC (extra-low-voltage control cable).



## Connect Contacts/Relays to the PDU Monitoring Unit

### ⚠️ DANGER

#### HAZARD OF ELECTRIC SHOCK, EXPLOSION, OR ARC FLASH

Ensure that wires are properly retained and away from high voltage lines and breakers.

**Failure to follow these instructions will result in death or serious injury.**

Make contact closure connections (NO or NC) at the user connection plate to monitor dry contacts. You can make eight connections – four input contacts and four output relays.

1. Make connections from inside the PDU cabinet, and route wires through the knockout provided on the user connection plate. For easier access, you can also remove the user connection plate and make the connections: Loosen the two captive screws and lift up the user connection plate. Make sure that you do not disconnect any existing connections.

#### View of PDU Roof

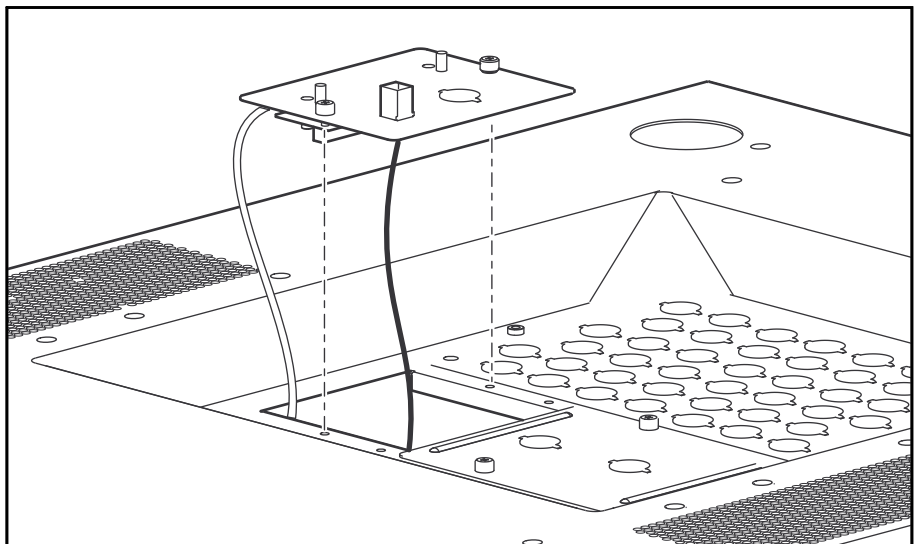

2. Choose one or more input contact/output relay numbers on the User/EPO contacts port on the user connection plate to which you will connect the input contacts/output relays. The user connection plate connects to the PDU monitoring unit.
3. From the PDU display, select **Contacts > Contacts Inputs > Contact In** or **Contacts > Relay Outputs > Relay Out** and press the Enter key to select the number of the input contacts/output relays you are connecting. The continue arrow ↓ will appear next to the input contact/output relay number.

```

Contact In:01of04
Name:UserContact1
Normal:Open
Status:Closed
  
```

4. Use the arrow keys to select the appropriate input contact/output relay number and press the Enter key.
5. Use the down arrow key to enter a unique **Name** for the input contact/output relay and to configure the **Normal** state of the input contact/output relay (Open or Closed). The default **Normal** state is Open. Press the Enter key to select the item to configure.

**NOTE:** You will be prompted for your password to configure these items.

6. Connect input contact/output relay wires (300 V-rated cabling required) to the User Contacts terminal block on the user connection plate. You will need a 2.5 mm standard screwdriver.
7. Run the wires from the user connection plate to your input contact/output relay location.

# Troubleshooting

## Status and Alarm Messages

This table lists all alarms that can be generated by the InfraStruXure PDU, as displayed by the **All Possible Alarms** option, with numeric variables between the < > characters. Logged alarms will display specific numbers instead.

Display Message	Description
Input V <Ln-N> = <Value> Voltage Under Limit	Input voltage of the phase indicated has dropped below the configured lower limit.
Input V <Ln-N> = <Value> Voltage Over Limit	Input voltage of the phase indicated exceeded the configured upper limit.
Output V <Ln-N> = <Value> Voltage Under Limit	Phase-to-neutral output voltage for phase dropped below the configured limit.
Output V <Ln-N> = <Value> Voltage Over Limit	Phase-to-neutral output voltage for phase exceeded the configured limit.
Output I L<n> = <Value> Current Over Limit	Current of output phase exceeded the configured limit.
Output I L<n> = <Value> Current Under Limit	Current of output phase dropped below the configured limit.
Output Neut = <Value> Current Over Limit	Current on the neutral wire for the output phases exceeded the configured limit.
Output FDev = <Value> Freq Out of Range	Frequency of the output current is above or below the range that is configured as acceptable.
Input Transformer Temperature	The temperature of the PDU transformer exceeded the normal limit.
Main Breaker Open Alarm Active	The Main Input switch is Off.
<User Contact Name> Alarm Active	A user-configured contact connected to the PDU monitoring unit is reporting an alarm condition.
No UPS Input Breaker Q1 Open	The Q1 circuit breaker is open, and the PDU is not receiving power from the UPS.
Branch Ckt Pos: <nn> Current Over Limit	Current on one of the poles of branch circuit breaker exceeded the configured limit.
Branch Ckt Pos: <nn> Current Under Limit	Current on one of the poles of branch circuit breaker dropped below the configured limit.

Schneider Electric  
35 rue Joseph Monier  
92500 Rueil Malmaison  
France

+ 33 (0) 1 41 29 70 00



\* 9 9 0 - 9 1 0 3 4 A \*

As standards, specifications, and design change from time to time,  
please ask for confirmation of the information given in this publication.

© 2017 – 2019 Schneider Electric. All rights reserved.

990-91034A