

Eaton SB21318KFB

Catalog Number: SB21318KFB

Eaton B-Line series runway shelf bracket, Steel, Flat black powder coat, 18" runway width, Triangular runway wall support kit

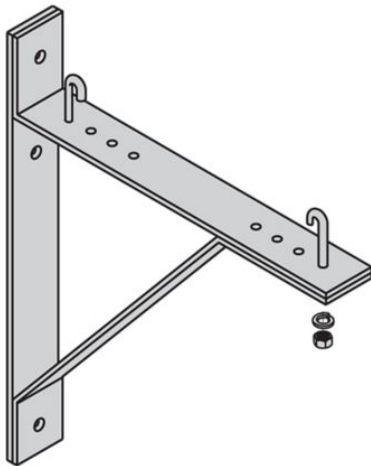

General specifications

Product Name	Catalog Number
Eaton B-Line series runway shelf bracket	SB21318KFB
UPC	Product Length/Depth
799038218111	19.88 in
Product Height	Product Width
19.13 in	1.75 in
Product Weight	Certifications
8.8 lb	Not Applicable

Product specifications

Model

Triangular runway wall support kit

Material

Steel

Finish

Flat black powder coat

Resources

Catalogs

[Cable runway and accessories section of datacomm catalog](#)

Specifications and datasheets

[Eaton Specification Sheet - SB21318KFB](#)



Eaton Corporation plc
Eaton House
30 Pembroke Road
Dublin 4, Ireland
Eaton.com
© 2023 Eaton. All Rights Reserved.

Eaton is a registered trademark.

All other trademarks are property of their respective owners.



[Eaton.com/socialmedia](https://www.eaton.com/socialmedia)