

Auxiliary Supports & Accessories

Wall Bracket

- Use to attach auxiliary structure to wall
- Material: 2" (51mm) x 2" (51mm) ASTM A1011 CS steel
- Finish ____: Flat black powder coat (FB)
Telco gray powder coat (TG)
Yellow zinc (YZ)
Other finishes are available upon request

Part Number	'A'		'B'		Weight	
	in.	(mm)	in.	(mm)	Lbs.	(kg)
SB211A__	6"	(152)	4"	(101)	1.9	(0.86)
SB211B__	6"	(152)	4"	(101)	1.9	(0.86)

Specify part number and finish when ordering.

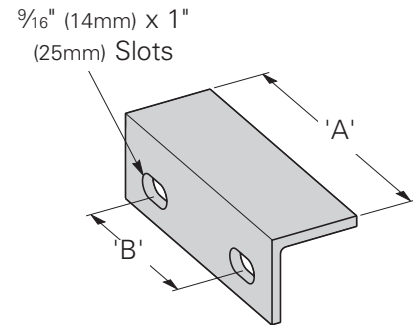

SB211A

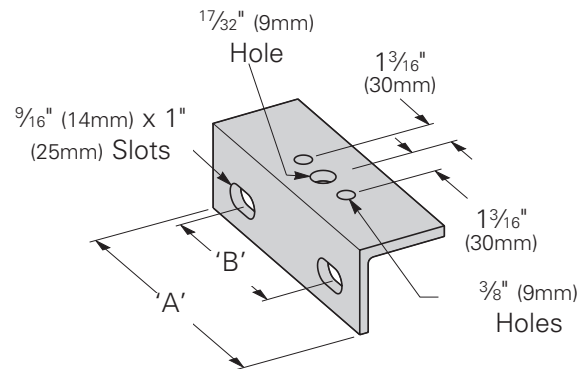

SB211B

End Cap

- Use as safety and protective coverings for cable runway stringers, support channel, tubes and bars
- Meets U.L. 94-V-O Flame Resistance requirement
- Sold in quantity of 10 pieces
- Material: Black Neoprene Rubber

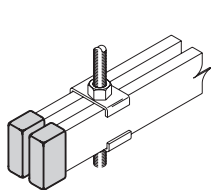

SB21

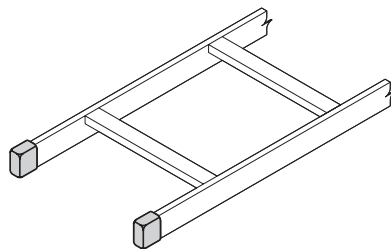

SB21B

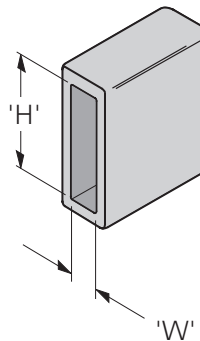

SB-21A

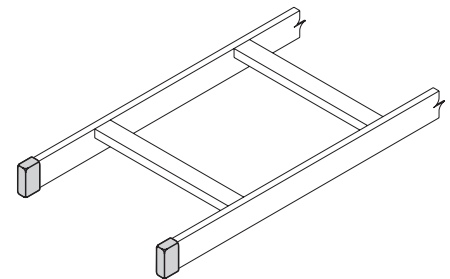

Part Number	Support Size 'H' x 'W'		Primary Usage	Weight	
	in.	(mm)		Lbs.	(kg)
SB21	2" x 9/16"	(51) x (14)	SB20 or SB22 Support	0.80	(0.36)
SB21A	2" x 3/8"	(51) x (9)	SB16 Runway	0.40	(0.18)
SB21B	1 1/2" x 3/8"	(38) x (9)	SB15, SB17 or SB18 Runway	0.30	(0.13)