

CAMPVC24 Camera Video, Data and Power Surge Protector

06/04/12

PRODUCT SPECIFICATION

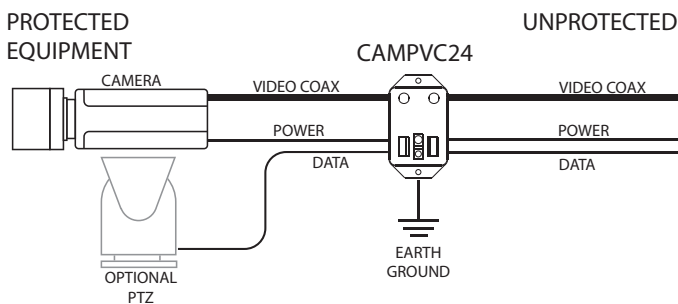
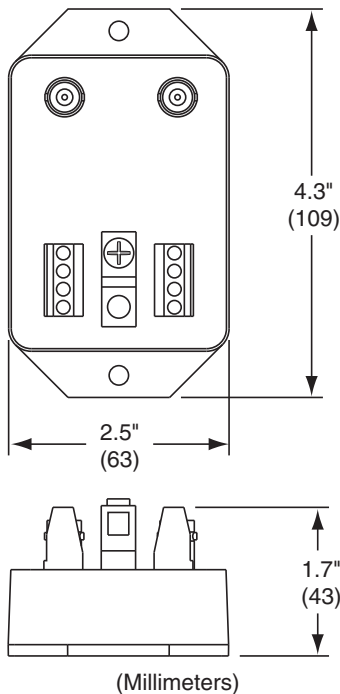

Description

The **CAMPVC24** is a single channel, multi-function surge protector for in-line coaxial video, twisted pair data and the 12 or 24 volt camera supply. The CAMPVC24 provides multi-stage surge protection to a single camera system and P/T/Z unit for each of these functions. The unit can be used at the camera or head-end. The CAMPVC24 is ideally suited for outdoor cameras, where extreme protection on all signal connections is required. The unit has BNC connectors at the input and output for connection to the coax and screw terminals at the inputs and outputs for connection to the data and power. The CAMPVC24 provides a heavy, single point ground connection and is easily installed in minutes.

Features

- Unique multi-stage design
- Insertion loss <0.2 dB
- Transient protection to
 - IEC61000-4-4 (EFT) 40A (5/50ns)
 - IEC61000-4-5 (Lightning) 24A (8/20µs)
- 2.8V clamping voltage
- Multi-function—protects video, data & camera power inputs
- Heavy single point ground
- Easy to install
- Lifetime warranty

Specifications

Size	1.7" H x 4.3" W x 2.5" D
Connection Method	Video—Female BNC connectors Power—Screw terminals Control—Screw terminals
Clamping Voltage	Video—2.8V Power—33Vrms Control—4.7V
Transient protection	IEC61000-4-4 (EFT) 40A (5/50ns) IEC61000-4-5 (Lightning) 24A (8/20µs)
Video Insertion Loss	<0.2dB
Impedance	50 or 75 Ohms
Temperature	-20°C to +65°C
Frequency	DC to 10 MHz
Shipping Weight	1 lb



NITEK®

USA

5410 Newport Drive, # 24
Rolling Meadows, IL 60008
Phone: (847) 259-8900
Fax: (847) 259-1300
E-mail: info@nitek.net
WWW.NITEK.NET

EUROPE

De Schans 19-21 2a
8231 KA Lelystad
Tel: +31(0)320-230005
Fax: +31(0)320-282186
E-mail: info@nitek.nl
WWW.NITEK.NL