

56-Electric Latch Retraction Exit Devices

With Optional 53-Latchbolt; 55-Request to Exit; & TL-[SARGuide] Connection

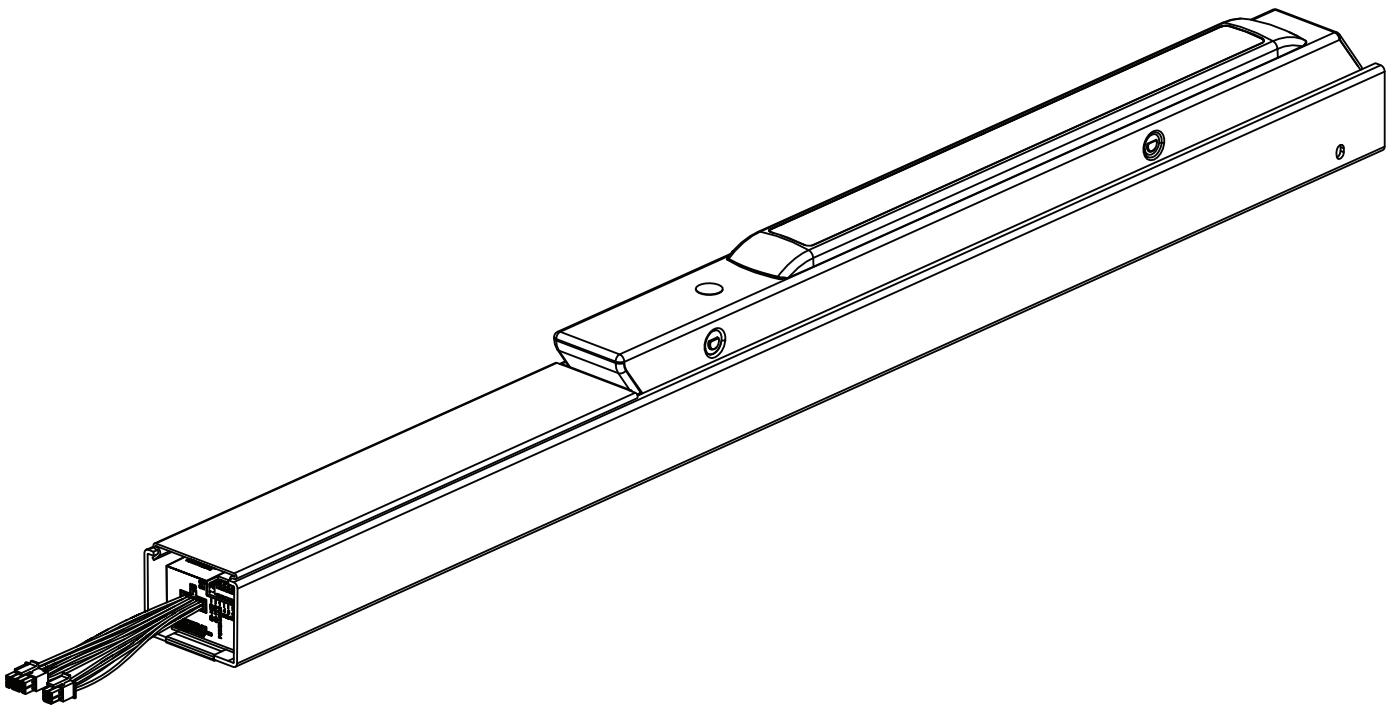

WARNING

This product can expose you to lead which is known to the state of California to cause cancer and birth defects or other reproductive harm. For more information go to www.P65warnings.ca.gov.

1-800-727-5477 • www.sargentlock.com

Copyright © 2017, 2021 SARGENT Manufacturing Company. All rights reserved. Reproduction in whole or in part without the express written permission of SARGENT Manufacturing Company is prohibited.

A7925F 7/21

Experience a safer
and more open world

56-Electric Latch Retraction Exit Devices

SARGENT[®]

ASSA ABLOY

with optional connections

Installation Manual

TOC	Table of Contents	
1	Overview	4
a	Description	4
b	Functions	4
c	Installation Notes	4
d	Hinge Requirements	5
e	Wire Gauge Chart	5
f	Wire Locations and Positions	6
g	DIP (Dual Inline Package) Switch Settings	6
h	ElectroLynx Wiring System	7
2	Power Mode Wiring	8
a	Installation Instructions	8
b	56- Input Requirements	9
c	ElectroLynx Opening Installation	10
d	Non-ElectroLynx Opening Installation	10
e	Typical Wiring	11
f	Configuration Instructions DIP Switch Settings (53-)	11
g	LED Signaling Chart	12
h	Power Mode Troubleshooting	12

56-Electric Latch Retraction Exit Devices

SARGENT[®]

ASSA ABLOY

with optional connections

Installation Manual

TOC	Table of Contents	
3	Timer Mode	14
a	Installation Instructions	14
b	56- Input Requirements	14
c	ElectroLynx Opening Installation.....	15
d	Non-ElectroLynx Opening Installation	16
e	Typical Wiring	17
f	Timer Mode Adjustment (Onboard Timer).....	17
g	Configurations Instructions DIP Switch Settings.....	18
h	LED Signaling Chart.....	18
i	Timer Mode Troubleshooting.....	19

56-Electric Latch Retraction Exit Devices

SARGENT

ASSA ABLOY

with optional connections

Installation Manual

1

Overview

a

Description

The Sargent 56- prefix ELR works with 80 Series exit devices to provide remote-controlled latch retraction. It is compatible with the following prefixes:

- 53 - Latchbolt Monitor Switch: The latch monitor provides tamper resistant latch monitoring. The monitor switch is activated when there is physical movement of the latch.
- 55 - Signal Switch (Request to Exit): This signal switch monitors the touch bar position. Touch bar monitoring can be used to detect egress, sound an alarm, send a signal to a remote location, or de-energize an electromagnetic lock.
- TL- (SARGuide): Illuminated touchpad for 80 Series exit devices.

Note: The 56- is also compatible with 16-, HK-, and 12- mechanical configurations.

b

Functions

The 56- ELR can be configured to work in either of two mode:

- Power Mode - (See Section 2): The device is not energized when locked. When electrified, the push rail and latch(es) will retract and remain in the retracted position until power is removed. Power is typically applied through a relay triggered by an access control device.
- Timer Mode - (See Section 3): The device is always energized and retraction is triggered by a momentary or maintain switch. In **TIMER MODE**:
 - When the timer circuit is closed using a **momentary** switch, the device retracts, remains retracted for a set duration, and releases. The duration of the retraction is set through an onboard timer setting.
 - When the timer circuit is closed using a **maintain** switch, the device retracts. The device releases when the contact is opened.



Caution: Disconnect all input power before servicing. Installer must be a trained and experienced service person. Wiring must comply with applicable local electrical codes, ordinances and regulations. Cylinder (16-) or “hex-key” (HK-) mechanical dogging cannot be used on fire rated doors.

c

Installation Notes

- The 56- ELR rail works only with Sargent 80 Series exit devices.
- Always perform mechanical installation using the appropriate installation instructions, prior to electrical wiring.
- If used in conjunction with M56 or R56 kits, follow instructions A7926 prior to using these instructions.
- Earth Ground: Required for electrostatic discharge (ESD) protection, unless already grounded through the metal door and frame.

56-Electric Latch Retraction Exit Devices

SARGENT

ASSA ABLOY

with optional connections

Installation Manual

1

Overview, continued

d

Hinge Requirements

Application	Without Timer		With Timer	
	Wires	Recommended Hinge	Wires	Recommended Hinge
56-	3 wires	QC8	5 wires	QC12
53- 56-	5 wires	QC8	7 wires	QC12
55- 56-	6 wires	QC8	8 wires	QC12
53- 55- 56-	8 wires	QC8	10 wires	QC12
TL-56-	5 wires	QC12	7 wires	QC12
TL-53- 56-	7 wires	QC12	9 wires	QC12
TL-55- 56-	8 wires	QC12	10 wires	QC12
TL-53- 55- 56-	10 wires	QC12	12 wires	QC12

e

Wire Gauge Chart

Total One-Way Length of Wire Run (ft)	Load Current @ 24VDC							
	1/4A	1/2A	3/4A	*1A	1-1/4A	1-1/2A	2A	3A
100	24	20	18	18	16	16	14	12
150	22	18	16	16	14	14	12	10
200	20	18	16	14	14	12	12	10
250	18	16	14	14	12	12	12	10
300	18	16	14	12	12	12	10	—
400	18	14	12	12	10	10	—	—
500	16	14	12	10	10	—	—	—
750	14	12	10	10	—	—	—	—
1,000	14	10	10	—	—	—	—	—
1,500	12	10	—	—	—	—	—	—

Note: When calculating voltage drop, use 1A as the recommended current draw for the 56- ELR.

56-Electric Latch Retraction Exit Devices

SARGENT

ASSA ABLOY

with optional connections

Installation Manual

1

Overview, continued

f

Wire Locations and Positions

The 56- ELR Electric Latch Retraction devices are supplied with one 4-pin and one 8-pin Molex® connector. Molex connectors allow simple installation using the ASSA ABLOY ElectroLynx® system.

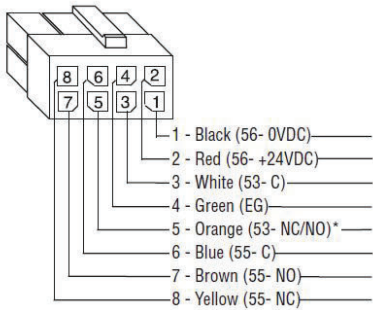

*NO/NC (Normally Open/Normally Closed) is selectable on controller (refer to 53- DIP switch instructions section III, part 5). Factory preset is NO.

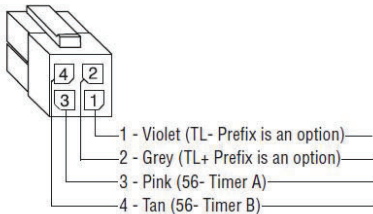
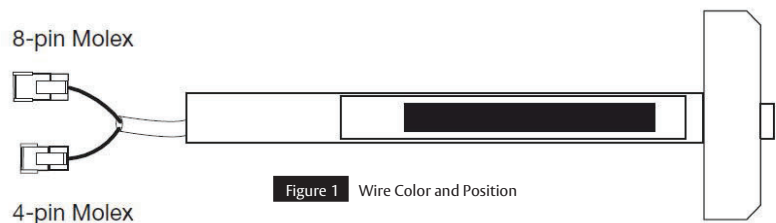

g

DIP (Dual Inline Package) Switch Settings

DIP Switch assignments are as follows, starting from left:

1. Closed (Switch set to **ON**) when selecting 53- **NC (Normally Closed)** contact.
2. Closed (Switch set to **ON**) when selecting 53- **NO (Normally Open)** contact.

Note: Only 1 or 2 should be closed at one time, not both.

3. Closed when bypassing external trigger, i. e., **Power Mode**.
- 4, 5, 6. Select software options, allows up to 8 **Time/Delay** settings (refer to **TIMER MODE**, Section 3-F).

Default Setting:

53- **NO (Normally Open)** and **POWER MODE** set to **ON**.

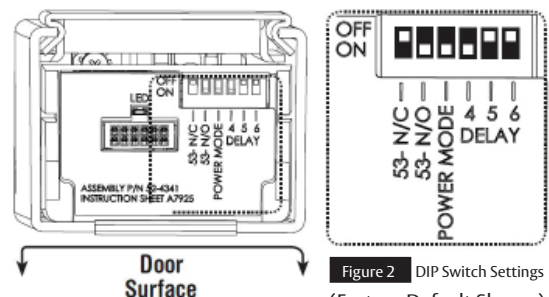

56-Electric Latch Retraction Exit Devices

with optional connections

Installation Manual

1

Overview, continued

h

ElectroLynx Wiring System

Important: ElectroLynx connectors plug and lock together in only one way. DO NOT force connectors together.

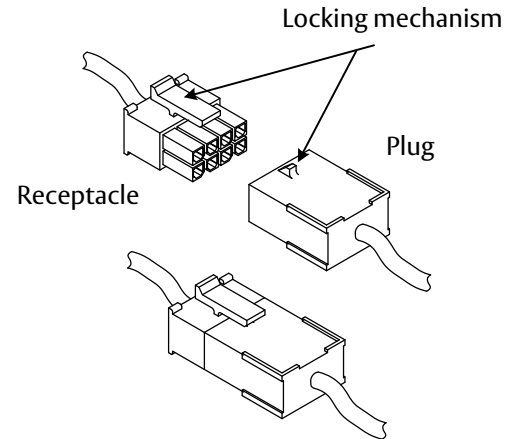

Figure 3 ElectroLynx Connections

Typical ElectroLynx Wiring Harness Connections

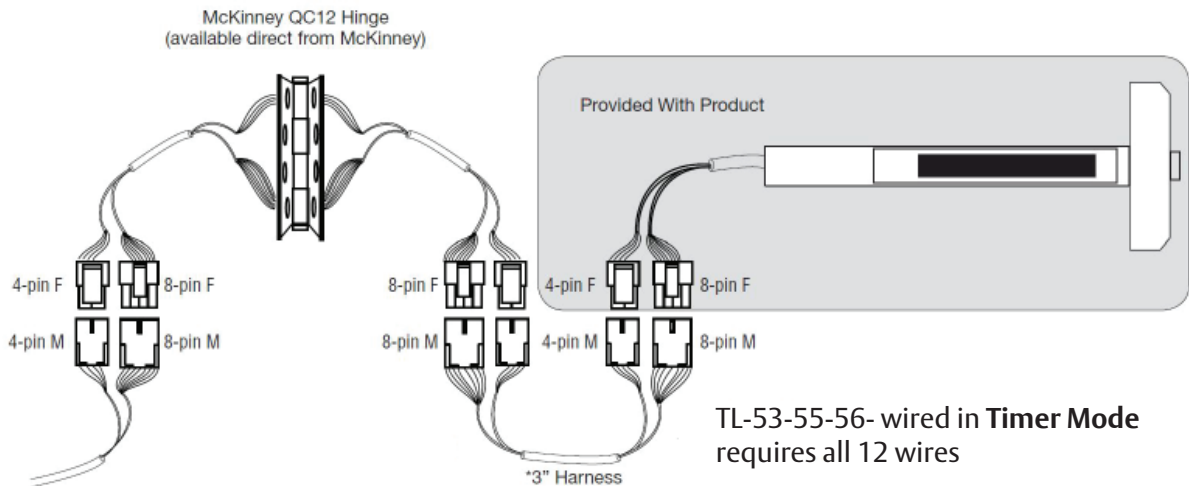

Figure 4 Typical ElectroLynx Connections

Note: The three inch connector is not included with the product, door, or hinge, and must be ordered separately. (Part number available in **Power Mode** Wiring section)

56-Electric Latch Retraction Exit Devices

SARGENT

ASSA ABLOY

with optional connections

Installation Manual

2

Power Mode Wiring

In this configuration, the device is not energized when locked. When energized with a 24 volt input, the push rail and latch(es) will retract and remain in the retracted position until power is removed. Power is typically applied through a relay triggered by an access control device. For installations using the onboard timer circuit, refer to Section 2: **Timer Mode**.

a

Installation Instructions

How it works: Rail retracts when power is applied and releases when power is removed.

1. Mount 80- Series exit device using mechanical installation instruction sheet(s) provided.

Note: Ensure proper mechanical function before attempting electrical retraction:

- Verify the push rail can be fully depressed and the latch is fully retracted.
- On vertical rod exit devices, verify the latchbolts do not enter hold-back-position until the push rail is fully depressed.
- Adjust device mechanically, as required, before applying power.

2. Connect the ElectroLynx harness in the door (Figure 7 ElectroLynx **Power Mode** Wiring):

- a. Plug the 8-pin ElectroLynx connector from the rail into the 3" ElectroLynx harness or splice into non-ElectroLynx harness (Figure 9 Non-ElectroLynx **Power Mode** Wiring).

- b. Feed the 3" harness through the 1" hole in the door and secure the rail to the door using the mounting bracket and two supplied screws (Figure 6 **Power Mode** Installation Diagram).

Note: Do not install the end cap until electrical operation is verified in order to confirm LED signalling. Do not discard the end cap and hardware.

3. Ensure DIP switch (position 3) enables **Power Mode** (Figure 5).
4. Connect the ElectroLynx harness to the hinge and secure the electric hinge to door.

Notes: Make sure no wires are pinched or damaged in the process. Refer to detailed wiring instructions under **Power Mode** wiring.

5. Apply 24V according to 56- input requirements (See next page):
Confirm that the LED is blinking, that the system fully unlocks, and that all bolts clear the strikes. Troubleshoot the device if issues are observed using the steps outlined at the end of the **Power Mode** section.
6. Store excess wiring under end cap and assemble with provided screws. Avoid pinching wires.

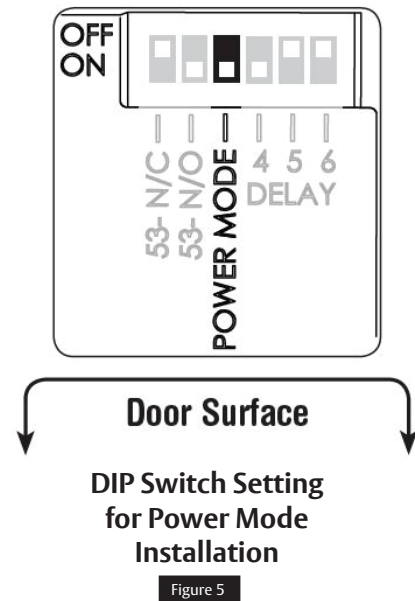

56-Electric Latch Retraction Exit Devices

SARGENT

ASSA ABLOY

with optional connections

Installation Manual

2

Power Mode Wiring, continued

a

Installation Instructions, continued

Figure 6 Power Mode Installation

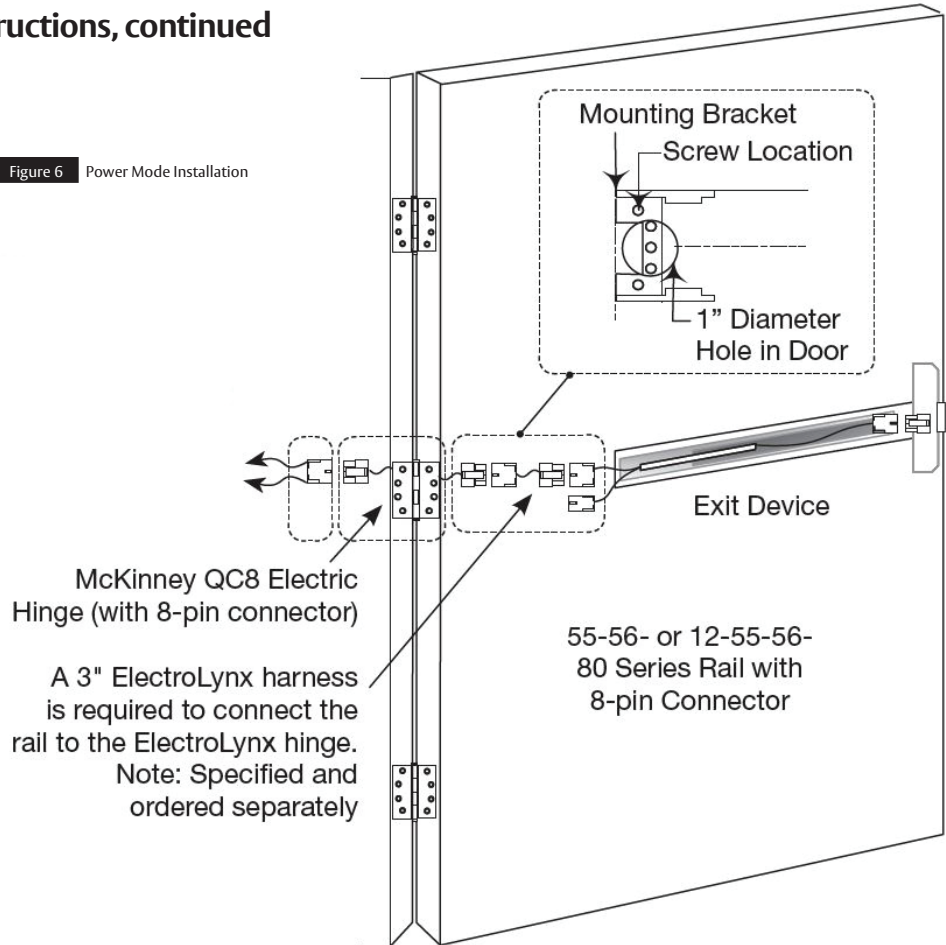

b

56- Input Requirements

Voltage: 24VDC

- Filtered and regulated power supply
- Motor operating current: 600mA
- Motor hold current: 250mA

	55- REX	53- LATCH BOLT
Contact Rating (Resistive)	300mA @ 30VDC	2A @ 30VDC
Contact Resistance	150m Ω	30m Ω

Note: Earth Ground is required for Electrostatic Discharge (ESD) protection unless the metal door and frame are already earth grounded; otherwise, earth ground wiring is required at pin 4 (Figure 7 ElectroLynx Power Mode Wiring).

56-Electric Latch Retraction Exit Devices

SARGENT

ASSA ABLOY

with optional connections

Installation Manual

2

Power Mode Wiring

c

ElectroLynx Opening Installation

This is the simplest installation method, requiring the installer to plug the ElectroLynx connectors from the exit device to the harness to the hinge and then to the pigtail, which is connected to the access control system.

- 56- exit device
- 3” ElectroLynx connector harness (not supplied with 56- device)
- McKinney QC ElectroLynx hinge (type of hinge depends on the application)
- ElectroLynx door

NO/NC (Normally Open/Normally Closed) is selectable on controller (refer to 53-DIP Switch Instructions in Section III). Factory preset is NO.

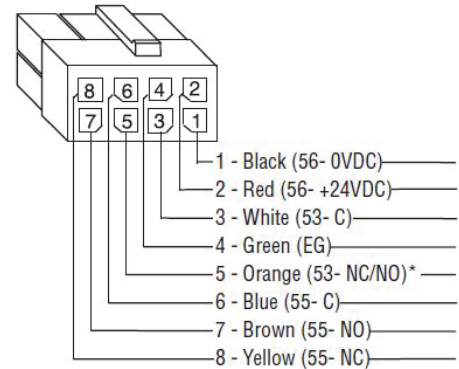

3” ElectroLynx Harness with 8-pin Connector (purchased separately)

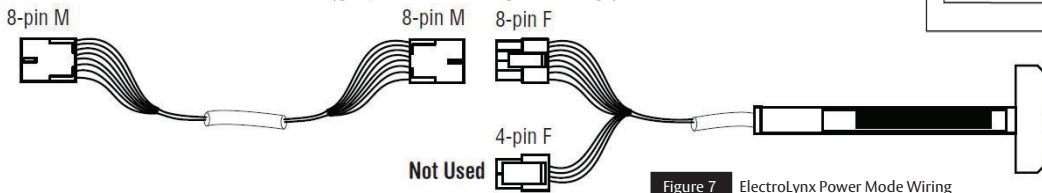

Figure 7 ElectroLynx Power Mode Wiring

d

ElectroLynx Opening Installation

Standard door with standard electric hinge: Molex connectors with flying leads can be purchased separately.

	MOLEX BOTH ENDS	MOLEX TO PINS
3 INCH	QC-C003	QC-C003P
6 INCH	QC-C006	QC-C006P
12 INCH	QC-C012	QC-C012P

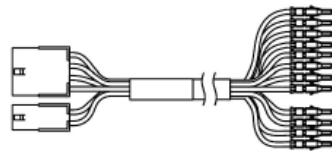

Molex with 12-pin Connector Pinned

Figure 8

To identify part numbers and order harness(es), visit the McKinney website, www.mckinneyhinge.com, and search the catalog for ElectroLynx.

If Molex pinned connectors are not available, remove the ElectroLynx connector from the 56- Exit Device and wire nut the 56- wires to the wires from the electric hinge (color coordinating wire colors is recommended).

Non-ElectroLynx Power Mode Wiring 56- Wires with ElectroLynx Connector Removed

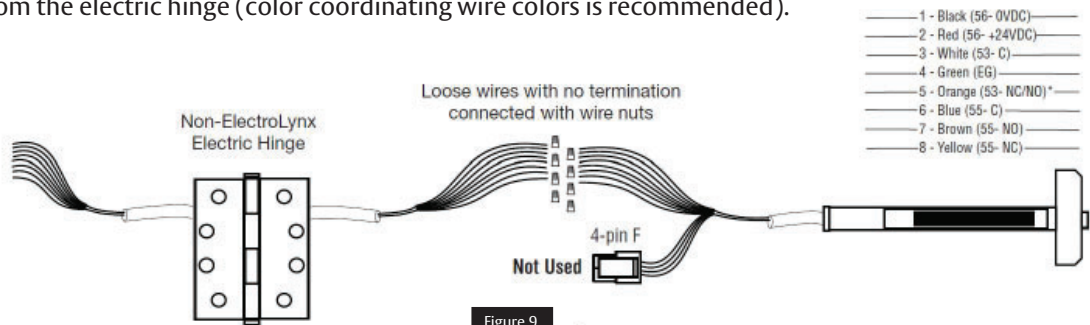

Figure 9

56-Electric Latch Retraction Exit Devices

SARGENT

ASSA ABLOY

with optional connections

Installation Manual

2

Power Mode Wiring, continued

e

Typical Wiring

For use when wiring in **Power Mode**.

- Onboard timer will not function in POWER MODE. Add external time delay if necessary.
- The switch is wired between the power supply and the load. Do not cycle the power supply.

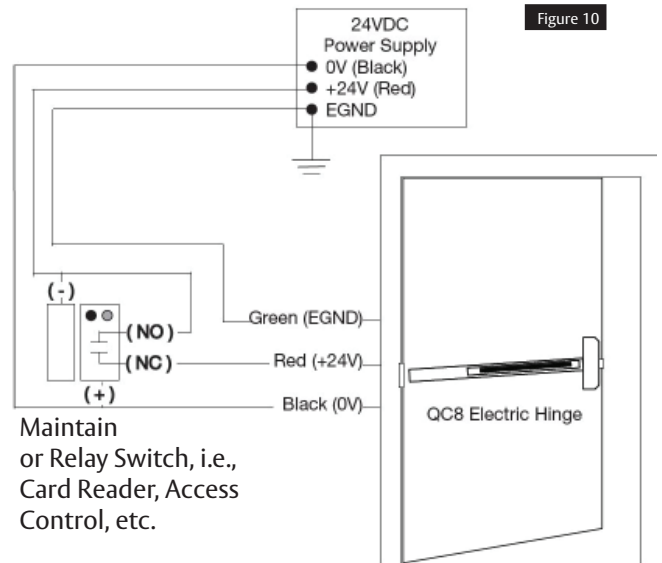

56- 80 Series Exit Device Typical **Power Mode** Wiring

f

Configuration Instructions DIP Switch Settings (53-)

For 56- applications using the optional 53- latchbolt monitor switch (53-56-), pin 5 of the 8-pin ElectroLynx connector will be either a NO contact or NC contact depending on the position of the DIP switches on the motor controller faceplate.

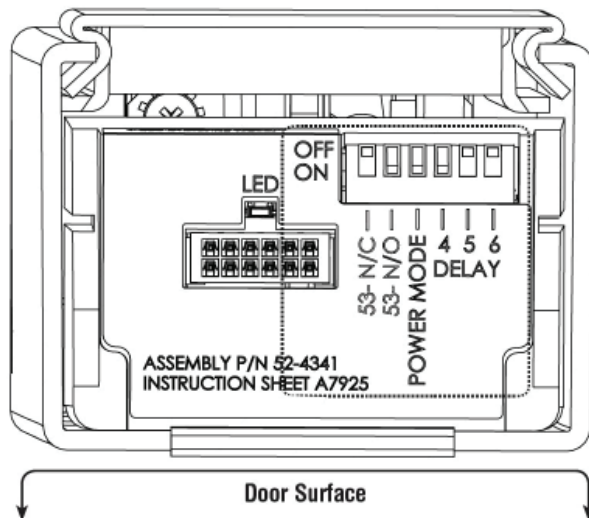
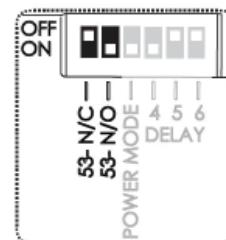
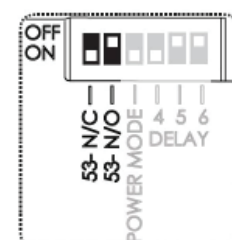

Figure 11



DIP Switch Setting for 53- Latch Bolt Monitoring
 NO (Default) Shown

Figure 12



NC Alternative DIP Switch Setting

56-Electric Latch Retraction Exit Devices

SARGENT

ASSA ABLOY

with optional connections

Installation Manual

2

Power Mode Wiring, continued

g

LED Signalling Chart

SIGNAL	CAUSE	TROUBLESHOOTING
Dark / Unlit	Controller microprocessor is not active	Confirm connections and incoming power
Steady Flashing	Normal operation	Check that POWER MODE switch is set
Solid Light	Input voltage is dropping out of operating range	Check wire run and power supply output
2 Flashes Followed by Pause	Retractor sensor problem	Call 800-810-WIRE for assistance

h

Troubleshooting

Prior to electrical troubleshooting, confirm that the mechanical system properly functions; i.e., that the push bar fully retracts all latches and the door opens freely. Refer to applicable Sargent 80 Series Exit Device product instruction sheet to correct mechanical installation issues.

Important: ALWAYS disconnect power before making any mechanical adjustments to the system.

The push rail does not move when 24V input is applied:

- Check inputs to confirm proper voltage and wiring orientation (Fig. 5 ElectroLynx **Power Mode** Installation).
- Remove end cap from rail and confirm that LED is blinking steadily when power is applied. If not, refer to LED signaling.

Note: When configured in **Power Mode**, power is released to lock the device (LED will not blink when power is released).

- Confirm DIP switch position 3 is set to ON.

The push rail does not fully retract or push rail retracts completely and holds but does not open door:

- Verify mechanical installation and correct as necessary:
 - Is excessive force required to depress the push bar?
 - Are latches fully clearing the strikes when mechanically cycled?

The push rail retracts and unlocks electrically but does not relock:

- Physically disconnect power from rail and confirm that input is off.
- Check for mechanical interference (e.g., warped door, lack of shims, misalignment of rail, etc.).
- Was a motor kit (M56) installed? Verify the rail assembly.

Rail behaves abnormally (multiple cycles, clicking, delayed retraction, etc.):

- Remove end cap from rail and confirm that LED is blinking steadily when power is applied. If not, refer to LED signaling.

Note: When configured in **Power Mode**, power is released to lock the device (LED will not blink when power is released).

56-Electric Latch Retraction Exit Devices

SARGENT[®]

ASSA ABLOY

with optional connections

Installation Manual

2

Power Mode Wiring, continued

h

Troubleshooting, continued

For applications using automatic operator(s): Door(s) fail to unlock before doors begin to open:

- Adjust timing of operator to allow 750ms for the rail to fully retract.

53- switch wiring: The design requires normally open functionality and the circuit is normally closed (or vice versa):

- There is only a two-wire input for the 53- circuit. Normally open or normally closed configuration is set by toggling the DIP switches on the controller bracket to the required position (refer to chart in section 2-d).

For additional installation assistance, please contact 1-800-810-WIRE (9473). When calling, please provide the following information to improve our service (provide what you can):

- Your name and contact number.
- Sargent 80 Series Exit Device product type (e.g. 55- 56- 8810).
- Location and identification of the affected opening (e.g., site, building, and door number).
- Sargent order number (located on product box), if available.
- Power supply manufacturer and rated output (i.e., voltage and current).
- Method of operation (e.g., **Power Mode**).
- The number of devices connected to the power supply.
- Symptoms of problem (i.e., observed behavior).

56-Electric Latch Retraction Exit Devices

SARGENT

ASSA ABLOY

with optional connections

Installation Manual

3

Timer Mode

In this configuration, the device is always energized with a 24 volt input, and a timer circuit is opened or closed to control rail retraction. A momentary or maintain switch is typically used to perform this operation. For installations where the power input is cycled to retract the device, refer to Section 2: Power Mode

a Installation Instructions

How it works: Rail retracts when timer input circuit is closed.

1. Mount 80- Series exit device using mechanical installation instruction sheet(s) provided.

Note: Ensure proper mechanical function before attempting electrical retraction:

- Verify the push rail can be fully depressed and the latch is fully retracted.
- On vertical rod exit devices, verify that the latchbolts do not enter hold-back position until the push rail is fully depressed.
- Adjust device mechanically, as required, before applying power.

2. Ensure DIP Switch switch (position 3) disables **Power Mode** (Figure 15). Set to OFF to disable.

3. Connect the ElectroLynx harness in the door (Figure 16 ElectroLynx **Timer Mode** Installation):
 - Plug the 8-pin and 4-pin ElectroLynx connectors from the rail into the 3" ElectroLynx harness or splice into a non-ElectroLynx harness (Figure 16 **Timer Mode** Installation).
 - Feed the 3" harness through the 1" hole in the door and secure the rail to the door using the mounting bracket and two supplied screws (Figure 16 **Timer Mode** Installation).

Note: Do not install the end cap until electrical operation is verified in order to confirm LED signaling. Do not discard the end cap and hardware.

b 56- Input Requirements

Voltage: 24VDC

- Filtered and regulated power supply
- Motor operating current: 600mA
- Motor hold current: 250mA

	55- REX	53- LATCH BOLT
Contact Rating (Resistive)	300mA @ 30VDC	2A @ 30VDC
Contact Resistance	150m Ω	30m Ω

Note: Earth Ground is required for Electrostatic Discharge (ESD) protection unless the metal door and frame are already earth grounded; otherwise, earth ground wiring is required at pin 4 (Figure 17 ElectroLynx **Timer Mode** Wiring).

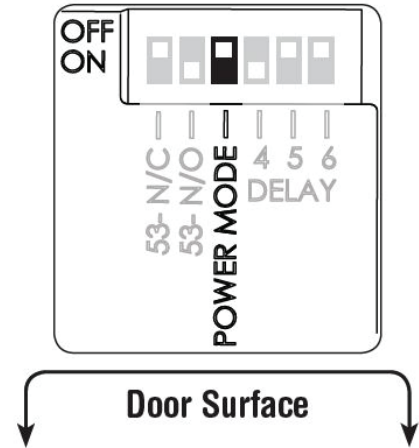

DIP Switch Setting for Timer Mode Installation

Figure 13

56-Electric Latch Retraction Exit Devices

SARGENT

ASSA ABLOY

with optional connections

Installation Manual

3

Timer Mode, continued

- Connect the ElectroLynx harness to the hinge:
 - Plug the door harness’s 8 pin and 4-pin connectors into the hinge’s ElectroLynx connector.
 - Secure the electric hinge to the door.

Note: Make sure no wires are pinched or damaged in the process. Refer to detailed wiring instructions under **Timer Mode** wiring.

- Apply 24V according to 56- input requirements:

Confirm that the LED is blinking and close the timer input circuit to retract the device. When the system retracts electrically, confirm that it fully unlocks and that all bolts clear the strikes. Troubleshoot the device if issues are observed using the steps outlined at the end of the **Timer Mode** section.

- Store excess wiring under end cap and assemble with provided screws. Avoid pinching wires.

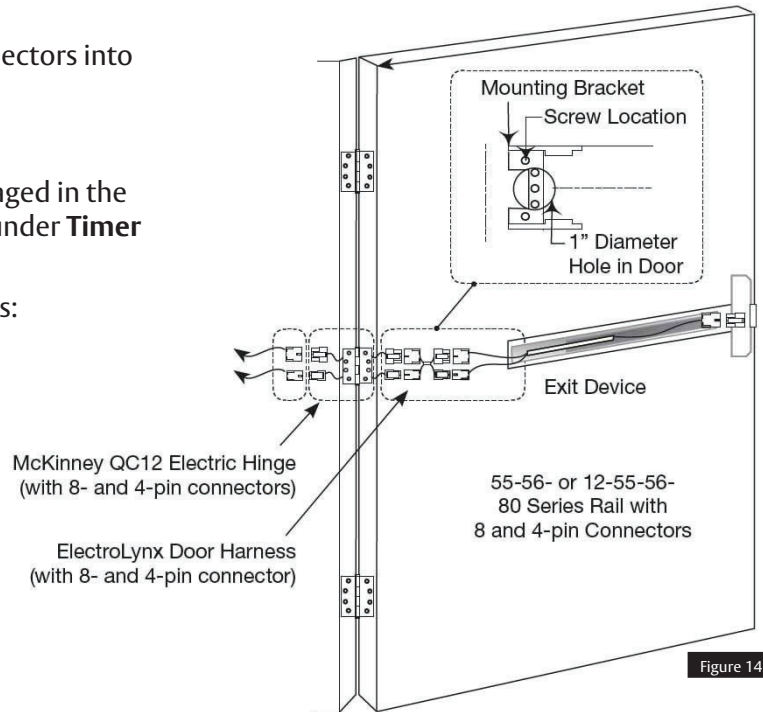

Figure 14

c ElectroLynx Opening Installation

This is the simplest installation method, requiring the installer to plug the ElectroLynx connectors from the exit device to the harness to the hinge and then to the pigtail, which is connected to the access control system.

Requirements

- 56- exit device
- 3” ElectroLynx connector harness (not supplied with 56- device)
- McKinney QC ElectroLynx hinge (type of hinge depends on the application)
- ElectroLynx door

3” ElectroLynx harness with 8-and 4-pin connectors (purchased separately)

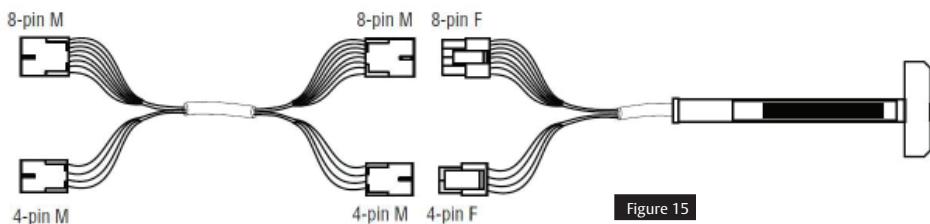
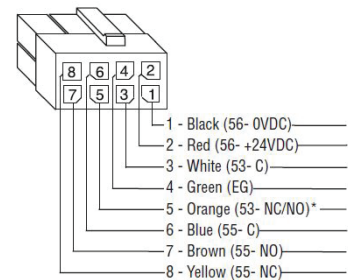
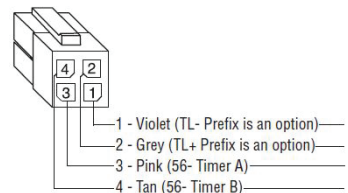

Figure 15



*NO/NC (Normally Open/Normally Closed) is selectable on controller (refer to 53- DIP switch instructions in this section, number 5). Factory preset is NO.



56-Electric Latch Retraction Exit Devices

SARGENT

ASSA ABLOY

with optional connections

Installation Manual

3

Timer Mode, continued

d

Non-ElectroLynx Opening Installation

Standard door with standard electric hinge: Remove the ElectroLynx connector from the 56- Exit Device and wire nut the 56- wires to the wires from the electric hinge (color coordinating wire colors is recommended).

	MOLEX BOTH ENDS	MOLEX TO PIN OUT
3 INCH	QC-C003	QC-C003P
6 INCH	QC-C006	QC-C006P
12 INCH	QC-C012	QC-C012P

To identify part numbers and order harness(es), visit the McKinney website, www.mckinneyhinge.com, and search the catalog for ElectroLynx.

- 1 - Black (56- 0VDC) —
- 2 - Red (56- +24VDC) —
- 3 - White (53- C) —
- 4 - Green (EG) —
- 5 - Orange (53- NC/NO)* —
- 6 - Blue (55- C) —
- 7 - Brown (55- NO) —
- 8 - Yellow (55- NC) —

*NO/NC (Normally Open/Normally Closed) is selectable on controller (refer to 53- DIP switch instructions in this section (III), part 5). Factory preset is NO.

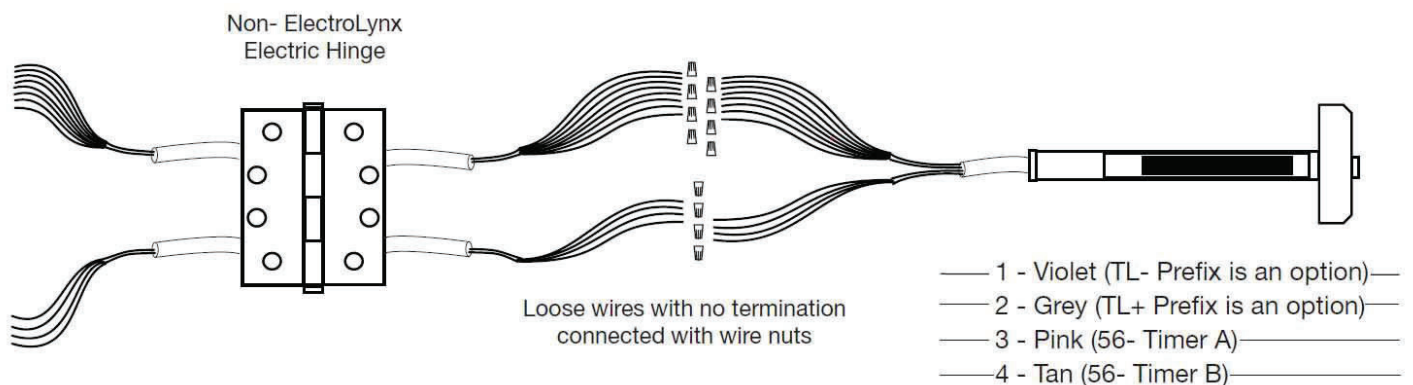

Figure 16

Non-ElectroLynx **Timer Mode** Connection 56- Wires with ElectroLynx Connector Removed

56-Electric Latch Retraction Exit Devices

SARGENT

ASSA ABLOY

with optional connections

Installation Manual

3

Timer Mode, continued

e

Typical Wiring

For use when wiring in **Timer Mode** (using the onboard timer). If more than 20 seconds timed delay is necessary, an external timer delay relay is required (not provided).

Note: 24V supply is constant in **Timer Mode**. Refer to settings in Section 3-G Configuration Instructions DIP Switch Settings (for 53- and timer duration).

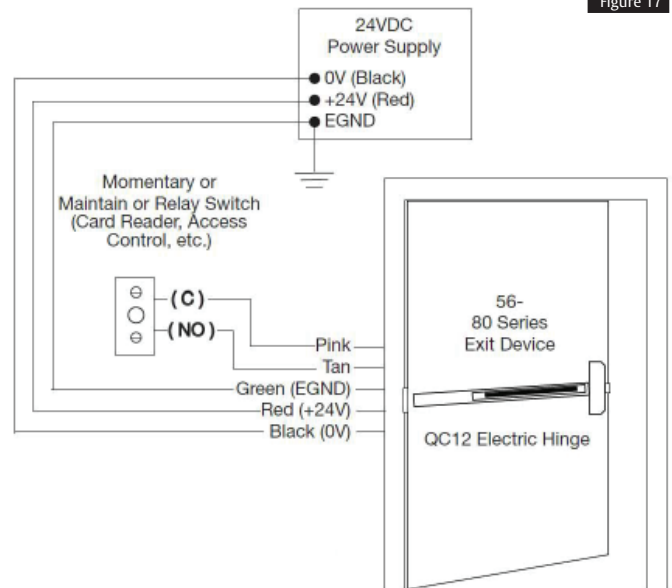

f

Timer Mode Adjustment (Onboard Timer)

How it works: The 24 volt input is always energized and the system retracts when the timer input circuit is closed.

- When the timer circuit is closed utilizing a momentary switch, the device retracts, remains retracted for a set duration, and releases. The duration of the retraction is set using an onboard timer setting (0 - 20 second timer adjustment).
- The countdown begins when the rail is first retracted.
- When the timer circuit is closed using a maintain switch, the device retracts.
- The device releases when the circuit is re-opened.

Notes:

- 24V supply is constant in **Timer Mode**. The duration of retraction is determined by whichever is longer: the maintain switch closure or the onboard timer delay.
- If more than 20 seconds delay is necessary (exceeding the maximum setting), an external timer delay relay is required (not provided).
- Refer to settings in Section 3-g (Fig. 18-20) for DIP Switch timer delay settings.

56-Electric Latch Retraction Exit Devices

SARGENT

ASSA ABLOY

with optional connections

Installation Manual

3

Timer Mode, continued

g

Configuration Instructions DIP Switch Settings (for 53- and timer duration)

For 56- applications using the optional 53- latchbolt monitor switch (53-56-), pin 5 of the 8-pin ElectroLynx connector will be either an NO contact or NC contact depending on the position of the DIP switches on the motor controller faceplate.

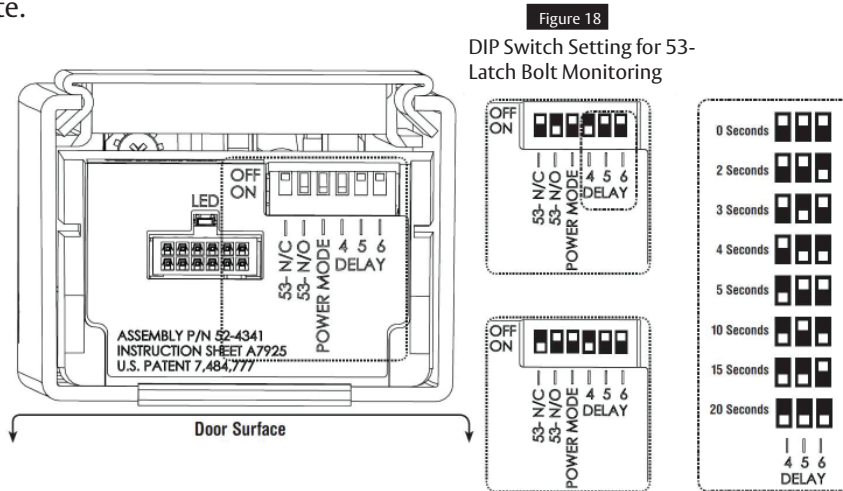

Figure 18

DIP Switch Setting for 53-Latch Bolt Monitoring

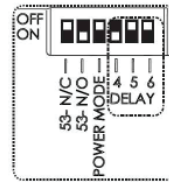

Figure 19

Alternate DIP Switch Setting (53- NC)

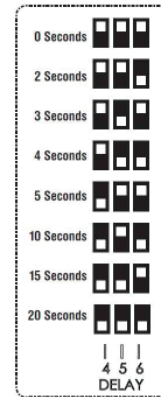

Figure 20

Timer Delay Settings (Default = 5 Seconds)

h

LED Signaling Chart

SIGNAL	CAUSE	TROUBLESHOOTING
Dark / Unlit	Controller microprocessor is not active	Confirm connections and incoming power
Steady Flashing	Normal operation	Cycle device by closing the timer circuit
Solid Light	Input voltage is dropping out of operating range	Check wire run and power supply output
2 Flashes Followed by Pause	Sensor or motor issue	Call 800-810-WIRE for assistance

i

Timer Mode Troubleshooting

Prior to electrical troubleshooting, confirm that the mechanical system properly functions; i.e., that the push bar fully retracts all latches and the door opens freely. Refer to applicable Sargent 80 Series Exit Device product instruction sheet to correct mechanical installation issues.

Important: ALWAYS disconnect power before making any mechanical adjustments to the system.

The push rail does not move when 24V input is applied:

- Check inputs to confirm proper voltage and wiring orientation. When configured for **Timer Mode**, 24V must be applied and the timer circuit must be closed to cycle the device
- Remove end cap from rail and confirm that LED is blinking steadily when power is applied. If not, refer to LED signaling.

56-Electric Latch Retraction Exit Devices

SARGENT[®]

ASSA ABLOY

with optional connections

Installation Manual

3

Timer Mode, continued

i

Timer Mode Troubleshooting

The onboard timer duration adjustment is not working:

- Remove power when making adjustments to timer delay settings (DIP Switches).
- When a momentary signal is applied to the timer circuit, the circuit must be reopened for the timer to function.

The push rail does not fully retract or push rail retracts completely and holds but does not open door:

- Verify mechanical installation and correct as necessary:
 - Is excessive force required to depress the push bar?
 - Are latches fully clearing the strikes when mechanically cycled?

The push rail retracts and unlocks electrically but does not relock:

- Confirm that the **Timer Mode** contact is opened (the rail will remain depressed until the contact is opened and the delay has expired).
- Physically disconnect power from rail (while electrically retracted) to verify if the issue is mechanical.
- Check for mechanical interference (e.g., warped door, lack of shims, misalignment of rail, etc.).
- Was a motor kit (M56) installed? Verify the rail assembly.

Rail behaves abnormally (multiple cycles, clicking, delayed retraction, etc.):

- If a momentary contact is applied to the timer circuit, adjust the onboard timer to a longer duration.
- Remove end cap from rail and confirm that LED is blinking steadily when power is applied. If not, refer to LED signaling.

For applications using automatic operator(s): Door(s) fail to unlock before doors begin to open:

- Adjust timing of operator to allow 750ms for the rail to fully retract.
- If a momentary contact is applied to the timer circuit, adjust the onboard timer to a longer duration to prevent the device from locking prior to operator actuation.

53- switch wiring: The design requires normally open functionality and the circuit is normally closed (or vice versa):

- There is only a two-wire input for the 53- circuit. Normally open or normally closed configuration is set by toggling the DIP switches on the controller bracket to the required position (refer to section 3-g).

For additional installation assistance, please contact 1-800-810-WIRE (9473). When calling, please provide the following information to improve our service (provide what you can):

- Your name and contact number.
- Sargent 80 Series Exit Device product type (e.g. 55- 56- 8810).
- Location and identification of the affected opening (e.g., site, building, and door number).
- Sargent order number (located on product box), if available.
- Power supply manufacturer and rated output (i.e., voltage and current).
- Method of operation (e.g., **Timer Mode**).
- The number of devices connected to the power supply.
- Symptoms of problem (i.e., observed behavior).

The ASSA ABLOY Group is the global leader in access solutions. Every day we help people feel safe, secure and experience a more open world.

SARGENT[®]
ASSA ABLOY

SARGENT Manufacturing Company
100 Sargent Drive
New Haven, CT 06511 USA
800-727-5477
www.sargentlock.com

1-800-727-5477 • www.sargentlock.com

Copyright © 2017, 2021 SARGENT Manufacturing Company. All rights reserved. Reproduction in whole or in part without the express written permission of SARGENT Manufacturing Company is prohibited.

A7925F 7/21

Experience a safer
and more open world