

# AL1024NKA8 Series

Dual Output Access Power Controllers

## Models Include:

Ordering Number:

### **AL1024NKA8**

8 Fused Outputs Kit

Fully assembled kit includes:

- BC400 Enclosure
- AL1024ULXB2 - Power Supply/Charger
- ACMS8 - Dual Input/Output Fused Access Power Controller
- VR6 - Voltage Regulator

Ordering Number:

### **AL1024NKA8D**

8 PTC Outputs Kit

Fully assembled kit includes:

- BC400 Enclosure
- AL1024ULXB2 - Power Supply/Charger
- ACMS8CB - Dual Input/Output PTC Access Power Controller
- VR6 - Voltage Regulator

## Installation Guide

All components of these kits are UL Listed sub-assemblies



Rev. AL1024NKA8-113021

**More than just power.™**

Installing Company: \_\_\_\_\_ Service Rep. Name: \_\_\_\_\_

Address: \_\_\_\_\_ Phone #: \_\_\_\_\_

## Overview:

Altronix AL1024NKA8 and AL1024NKA8D distribute and switch power to access control systems and accessories. They convert a 115VAC 60Hz input into eight (8) independently controlled 12VDC or 24VDC protected outputs. Access Power Controller's dual input design allows power to be steered from two (2) factory installed independent low voltage 12 or 24VDC Altronix power supplies to eight (8) independently controlled fuse (AL1024NKA8) or PTC (AL1024NKA8D) protected outputs. Power outputs can be converted to dry form "C" contacts. Outputs are activated by an open collector sink, normally open (NO), normally closed (NC) dry trigger input, or wet output from an Access Control System, Card Reader, Keypad, Push Button, PIR, etc. AL1024NKA8(D) will route power to a variety of access control hardware devices including Mag Locks, Electric Strikes, Magnetic Door Holders, etc. Outputs will operate in both Fail-Safe and/or Fail-Secure modes. The FACP Interface enables Emergency Egress, Alarm Monitoring, or may be used to trigger other auxiliary devices. The fire alarm disconnect feature is individually selectable for any or all of the eight (8) outputs. The spade connectors allow you to daisy chain power to multiple ACMS8(CB) modules. This feature allows you to distribute the power over more outputs for larger systems.

## Agency Listings:

### AL1024ULX:

#### UL Listings for US Installations:

UL 294 - UL Listed for Access Control System Units.

UL 1481 - UL Listed for Power Supplies for Fire Protective Signaling Systems.

#### UL Listings for Canadian Installations:

CSA C22.2 No.205-M1983 - Signal Equipment

### ACMS8, ACMS8CB and VR6:

#### UL Listings for US Installations:

UL 294 7th Edition: Access Control System Units.

#### UL Listings for Canadian Installations:

ULC-S319: Electronic Access Control Systems.

## Stand-by Specifications (total current shown):

Output	15 min. of Stand-by and 5 min. of Alarm	4 hr. of Stand-by and 5 min. of Alarm	24 hr. of Stand-by and 5 min. of Alarm	60 hr. of Stand-by and 5 min. of Alarm
24VDC/12AH Battery	Stand-By = 8A Alarm = 10A	Stand-By = 1.5A Alarm = 10A	Stand-By = 200mA Alarm = 10A	Stand-By = 100mA Alarm = 10A
Output	15 min. of Stand-by and 5 min. of Alarm	4 hr. of Stand-by and 5 min. of Alarm	24 hr. of Stand-by and 15 min. of Alarm	60 hr. of Stand-by and 15 min. of Alarm
24VDC/65AH Battery	—	Stand-By = 8.0A Alarm = 10A	Stand-By = 1.5A Alarm = 10A	Stand-By = 500mA Alarm = 10A

For Access Control applications, battery capacity for 10A supply current - 1 hr. for 24VDC/12AH battery, 6.5 hrs. for 24VDC/65AH battery.

See battery size calculation worksheet for other batteries (*Page 6*).

## Specifications:

### Inputs:

#### AL1024ULXB2:

- 115VAC, 60Hz, 4.2A.

#### ACMS8/ACMS8CB:

- Eight (8) trigger inputs:
  - a) Normally open (NO) inputs (dry contacts).
  - b) Normally closed (NC) inputs (dry contacts).
  - c) Open collector sink inputs.
  - d) Wet Input (5VDC - 24VDC) with 10K resistor
  - e) Any combination of the above.

### Outputs:

#### Power:

- 12VDC or 5VDC up to 6A, 24VDC up to 10A (240W total power).
- Overvoltage protection.

#### ACMS8:

- Fuse protected outputs rated @ 2.5A per output, non power-limited. Total output 6A max. Do not exceed the individual power supply ratings.

#### ACMS8CB:

- PTC protected outputs rated @ 2A per output, Class 2 power-limited. Total output 6A max. Do not exceed the individual power supply ratings.
- Eight (8) selectable independently controlled outputs or eight (8) independently controlled Form "C" relay outputs (see below for ratings):
  - a) Fail-Safe and/or Fail-Secure power outputs.
  - b) Form "C" relays rated @ 2.5A, 12, 24VDC, 0.6 Power Factor (ACMS8 only).
  - c) Auxiliary power outputs (unswitched).
  - d) Any combination of the above.
- Individual outputs may be set to OFF position for servicing (output jumper set to middle position). Does not apply to Dry Contact applications.
- Any of the eight (8) fuse/PTC protected power outputs are selectable to follow power Input 1 or Input 2. Output voltage of each output is the same as the input voltage of the input selected.
- Surge suppression.

### Fuse/PTC Ratings:

#### AL1024ULXB2:

- Input fuse is rated 5A/250V.
- Battery fuse rated 15A/32V.

#### ACMS8:

- Main input fuse is rated 15A/32V.
- Output fuses are rated 3A/32V.

#### ACMS8CB:

- Main input PTC is rated 9A.
- Output PTCs are rated 2A.

### Battery Backup:

- Built-in charger for sealed lead acid or gel type batteries.
- Automatic switch over to stand-by battery when AC fails.
- Maximum charge current 3.6A.
- Zero voltage drop when switched over to battery backup.

### Supervision:

- AC fail supervision (form "C" contacts).
- Low battery supervision (form "C" contacts).
- Battery presence supervision (form "C" contacts).

### Fire Alarm Disconnect:

- Fire Alarm disconnect (latching or non-latching) is individually selectable for any or all of the eight (8) outputs.

Fire Alarm disconnect input options:

- a) Normally open [NO] or normally closed [NC] dry contact input. Polarity reversal input from FACP signaling circuit.
- FACP input WET is rated 5-30VDC 7mA.
  - FACP input EOL requires 10K end of line resistor.
  - FACP output relay [NC]:  
Either Dry 1A/28VDC, 0.6 Power Factor or 10K resistance with [EOL JMP] intact.

### Visual Indicators:

#### AL1024ULXB2:

- **Green AC LED:** Indicates 115VAC present.
- **Red DC LED:** Indicates DC output.

#### ACMS8(CB):

- **Red LEDs:** Indicate outputs are triggered.
- **Blue LED:** Indicates FACP disconnect is triggered.
- **Individual Voltage LEDs:** Indicate 12VDC (Green) or 24VDC (Red).

### Environmental:

- Operating temperature: 0°C to 49°C ambient.
- Humidity: 20 to 85%, non-condensing.

### Enclosure Dimensions (approximate H x W x D):

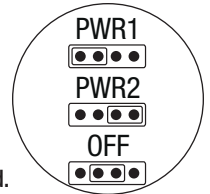
15.5" x 12" x 4.5"  
(393.7mm x 304.8mm x 114.3mm).

## Installation Instructions:

Wiring methods shall be in accordance with the National Electrical Code/NFPA 70/NFPA 72/ANSI, the Canadian Electrical Code and with all local codes and authorities having jurisdiction. Product is intended for indoor use only.

1. Mount unit in desired location. Mark and predrill holes in the wall to line up with the top two keyholes in the enclosure. Install two upper fasteners and screws in the wall with the screw heads protruding. Place the enclosure's upper keyholes over the two upper screws, level and secure. Mark the position of the lower two holes. Remove the enclosure. Drill the lower holes and install the two fasteners. Place the enclosure's upper keyholes over the two upper screws. Install the two lower screws and make sure to tighten all screws (*Enclosure Dimensions, pg. 12*). Secure enclosure to earth ground.
2. Ensure all output jumpers [PWR1] - [PWR8] are placed in the OFF (center) position (*Fig. 1, pg. 3*).

Fig. 1



3. Connect unswitched AC power (115VAC 60Hz) to terminals marked [L, N] (*Fig. 4a, pg. 5*). Green "AC" LED on power supply board will turn on. This light can be seen through the LED lens on the door of the enclosure. Use 14 AWG or larger for all power connections. Secure green wire lead to earth ground.

### Keep power-limited wiring separate from non power-limited wiring

(115VAC 60Hz Input, Battery Wires). Minimum 0.25" spacing must be provided.

**CAUTION: Do not touch exposed metal parts. Shut branch circuit power before installing or servicing equipment. There are no user serviceable parts inside.**

Refer installation and servicing to qualified service personnel.

4. Set each output [OUT1] - [OUT8] to route power from Input 1 or 2 (*Fig. 1, pg. 3*).  
**Note:** Measure output voltage before connecting devices. This helps avoiding potential damage.
5. Turn power off before connecting devices.

6. Output options: AL1024NKA8(D) will provide up to eight (8) switched power outputs or eight (8) dry form "C" outputs, or any combination of both switched power and form "C" outputs, plus eight (8) unswitched auxiliary power outputs.

### Switched Power outputs:

Connect the negative (-) input of the device being powered to the terminal marked [COM].

- For Fail-Safe operation connect the positive (+) input of the device being powered to the terminal marked [NC].
- For Fail-Secure operation connect the positive (+) input of the device being powered to the terminal marked [NO].

### Form "C" outputs:

When form "C" outputs are desired, the corresponding jumper (1-8) must be placed in the OFF position (*Fig. 7, pg. 9*). Alternatively, the corresponding output fuse (1-8) can be removed (AL1024NKA8 only). Connect negative (-) of the power supply directly to the locking device.

Connect the positive (+) of the power supply to the terminal marked [C].

- For Fail-Safe operation connect the positive (+) of the device being powered to the terminal marked [NC].
- For Fail-Secure operation connect the positive (+) of the device being powered to the terminal marked [NO].

Dry contacts rated @ 2.5A, 28VDC.

### Auxiliary Power outputs (unswitched):

Connect positive (+) input of the device being powered to the terminal marked [C] and the negative (-) of the device being powered to the terminal marked [COM]. Output can be used to provide power for card readers, keypads etc.

7. Turn main power on after all devices are connected.
8. **Input Trigger options:**

**Note:** If Fire Alarm disconnect is not used, connect a 10K ohm resistor to terminals marked [GND and EOL], plus connect a jumper to terminals marked [GND, RST].

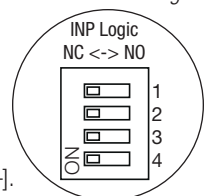
### Normally Open (NO) Input:

Slide input control logic DIP switch into the OFF position for [Switch 1-8] (*Fig. 2, on right*). Connect your wires to terminals marked [+ INP1 -] to [+ INP8 -].

### Normally Closed (NC) Input:

Slide input control logic DIP switch into the ON position for [Switch 1-8] (*Fig. 2, on right*). Connect your wires to terminals marked [+ INP1 -] to [+ INP8 -].

Fig. 2



### Open Collector Sink Input:

Connect the open collector sink input to the terminal marked [+ INP1 -] to [+ INP8 -].

### Wet (Voltage) Input Configuration:

Carefully observing polarity, connect the voltage input trigger wires and the supplied 10K resistor to terminals marked [+ INP1 -] to [+ INP8 -].

If applying voltage to trigger input - set the corresponding INP Logic switch to the "OFF" position

If removing voltage to trigger input - set the corresponding INP Logic switch to the "ON" position.

### 9. Fire Alarm Interface options:

A normally closed [NC], normally open [NO] input or polarity reversal input from FACP signaling circuit will trigger selected outputs. To enable FACP Disconnect for an output turn the corresponding DIP switch [SW1-SW8] ON.

To disable FACP disconnect for an output turn the corresponding DIP switch [SW1-SW8] OFF. Switch is located directly to the left of the Fire Alarm Interface Terminals.

#### Normally Open Input:

Wire your FACP relay and 10K resistor in parallel on terminals marked [GND] and [EOL].

#### Normally Closed Input:

Wire your FACP relay and 10K resistor in series on terminals marked [GND] and [EOL].

#### FACP Signaling Circuit Input Trigger:

Connect the positive (+) and negative (-) from the FACP signaling circuit output to the terminals marked [+ FACP -]. Connect the FACP EOL to the terminals marked [+ RET -] (polarity is referenced in an alarm condition).

**Non-Latching Fire Alarm Disconnect:** Connect a jumper to the terminals marked [GND, RST].

**Latching Fire Alarm Disconnect:** Connect a NO normally open reset switch to terminals marked [GND, RST].

### 10. FACP Dry NC output:

Connect desired device to be triggered by the unit's dry contact output to the terminals marked [NC] and [C]. When [EOL JUMP] is kept intact, the output is of 0 Ohm resistance in a normal condition.

When [EOL JUMP] is clipped, a 10k resistance will be passed to next device when in a normal condition.

### 11. Stand-by Battery Connections (Fig. 6, pg. 8):

For U.S. Access Control applications batteries are optional. Batteries are required for Canadian installations (ULC-S319). When batteries are not used, a loss of AC will result in the loss of output voltage.

When the use of stand-by batteries is desired, they must be lead acid or gel type.

Connect battery to terminals marked [- BAT +] (Fig. 4g, pg. 6). Use two (2) 12VDC batteries connected in series for 24VDC operation (battery leads included). Use batteries - Casil CL1270 (12V/7AH), CL12120 (12V/12AH), CL12400 (12V/40AH), CL12650 (12V/65AH) batteries or UL recognized BAZR2 and BAZR8 batteries of an appropriate rating.

### 12. Battery and AC Supervision outputs (Fig. 4, pg. 8):

Connect appropriate signaling notification devices to the terminals marked [AC FAIL & BAT FAIL] (Fig. 4b, pg. 5) supervisory relay outputs.

Use 22 AWG to 18 AWG for AC Fail & Low/No Battery reporting.

### 13. To delay reporting for up to 6 hrs., cut "AC Delay" jumper and reset power to unit (Fig. 4f, pg. 6).

### 14. Fire Alarm Disconnect (Fig. 4c, pg. 6):

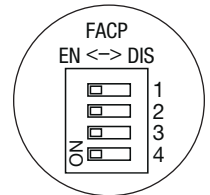
To enable Fire Alarm Disconnect set DIP switch [Shutdown] to ON position.

To disable Fire Alarm Disconnect set DIP switch [Shutdown] to OFF position.

### 15. Installation of tamper switch:

Mount UL Listed tamper switch (Altronix model TS112 or equivalent) at the top of the enclosure. Slide the tamper switch bracket onto the edge of the enclosure approximately 2" from the right side (Fig. 6a, pg. 8). Connect tamper switch wiring to the Access Control Panel input or the appropriate UL Listed reporting device. To activate alarm signal open the door of the enclosure.

Fig. 3



## Wiring:

Use 18 AWG or larger for all low voltage power connections.

**Note:** Take care to keep power-limited circuits separate from non power-limited wiring (115VAC, Battery).

## Maintenance:

Unit should be tested at least once a year for the proper operation as follows:

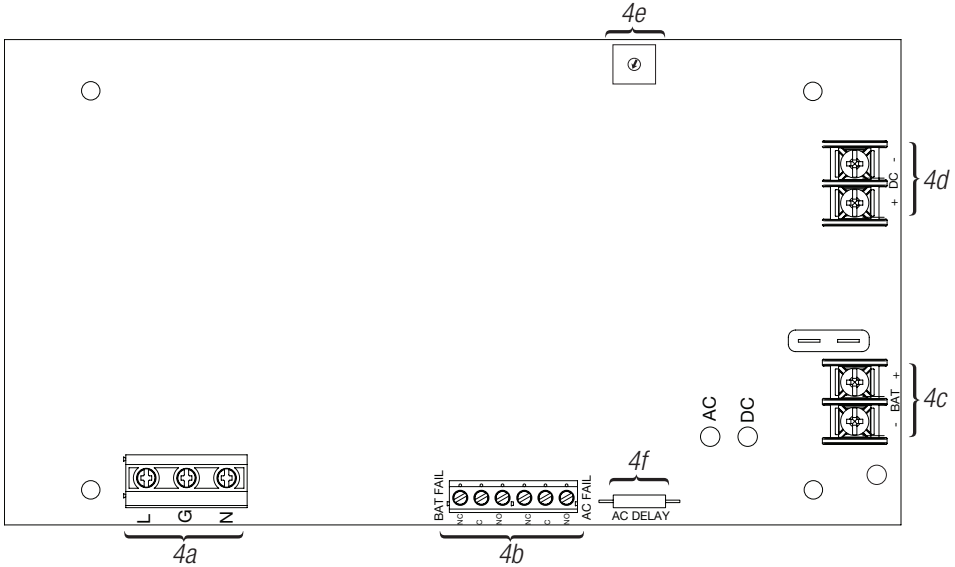
**Output Voltage Test:** Under normal load conditions the DC output voltage should be checked for proper voltage level.

**Battery Test:** Under normal load conditions check that the battery is fully charged, check specified voltage both at the battery terminal and at the board terminals marked [- BAT +] to ensure that there is no break in the battery connection wires.

**Note:** Maximum charging current under discharges is 3.6A.

**Note:** Expected battery life is 5 years; however, it is recommended changing batteries in 4 years or less if needed.

Fig. 4 - AL1024ULXB2 Board Configuration



## Battery Size Calculation Worksheet:

A. AL1024NKA8(D) internal current consumption	(stand-by)	_____	0.05 A
B. Load current consumption	(stand-by)	_____	A
C. Stand-by time required (hours)		_____	H
D. Battery capacity required for stand-by	$(A+B)*C$	_____	AH
E. AL1024NKA8(D) internal power consumption	(Alarm)	_____	0.05 A
F. Load current consumption	(Alarm)	_____	A
G. Alarm duration (Hours; 15 Min. = 0.25 Hour)	(Alarm)	_____	H
H. Battery capacity required for Alarm	$(E+F)*G$	_____	AH
I. Total calculated battery capacity	D+H	_____	AH
J. Battery capacity required	$I*1.8$ (safety factor)	_____	AH

**Note:** AL1024NKA8(D) power supply is designed to work with batteries up to 65AH.

Please note: line [J] must not exceeds 36AH.

You have to reduce either stand-by current consumption or stand-by time in order to comply with requirement.

To determine actual battery size please round line [J] to the nearest larger standard battery size (e.g. 3.5 AH = 4.0 AH).

## LED Diagnostics:

### AL1024ULXB2 - Power Supply Board

Red (DC)	Green (AC)	Power Supply Status
ON	ON	Normal operating condition.
ON	OFF	Loss of AC. Stand-by battery is supplying power.
OFF	ON	No DC output.
OFF	OFF	Loss of AC. Discharged or no stand-by battery. No DC output.

### ACMS8 and ACMS8CB Access Power Controller

LED	ON	OFF
LED 1 - LED 8 (Red)	Output relay(s) de-energized.	Output relay(s) energized.
FACP	FACP input triggered (alarm condition).	FACP normal (non-alarm condition).
Green Output 1-8	12VDC	–
Red Output 1-8	24VDC	–

## Terminal Identification:

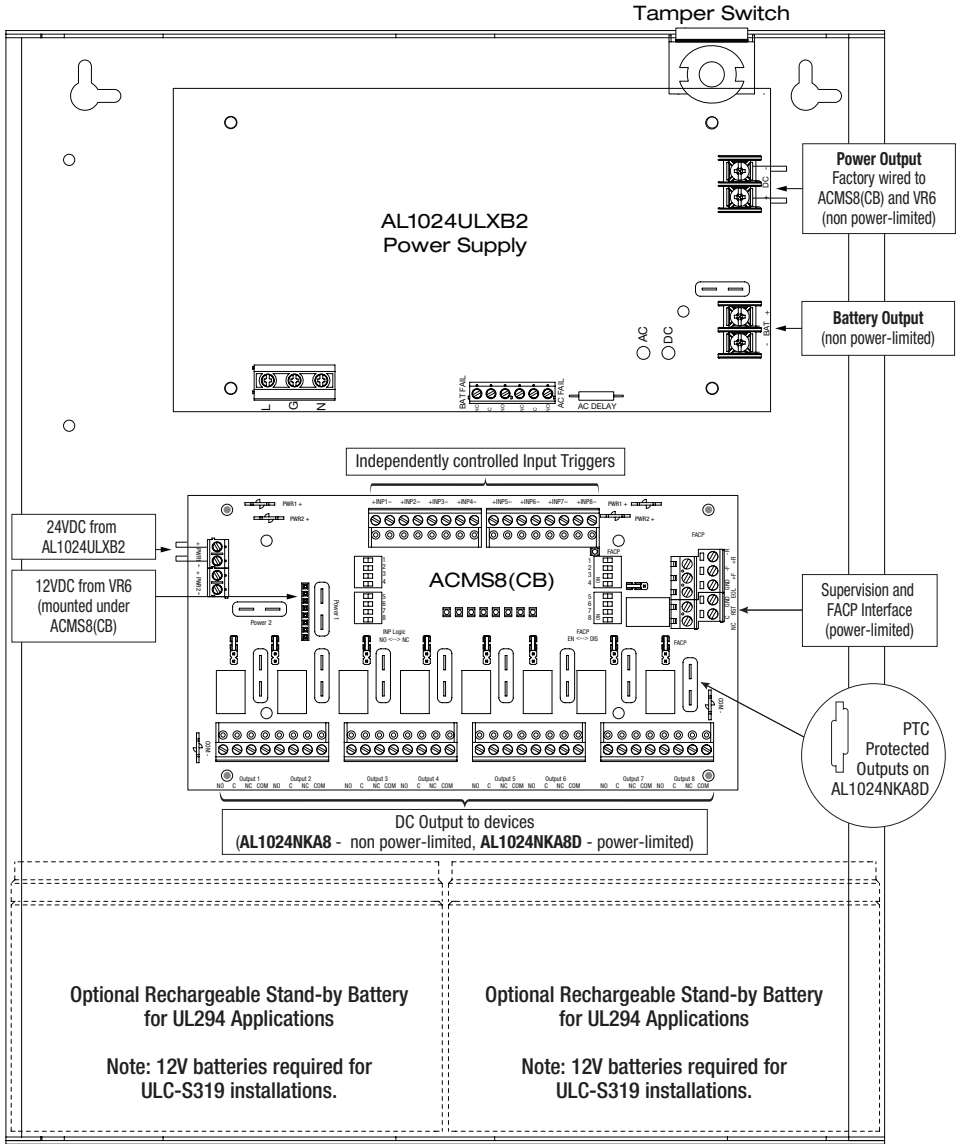
### AL1024ULXB2 - Power Supply Board

Terminal Legend	Function/Description
L, N	Connect 115VAC to these terminals: L to hot, N to neutral ( <i>Fig. 4a, pg. 6</i> ).
+ DC –	Factory connected to ACMS8(CB) ( <i>Fig. 4d, pg. 6</i> ).
AC Fail NC, C, NO	Used to notify loss of AC power, e.g. connect to audible device or alarm panel. Relay normally energized when AC power is present. Contact rating 1A @ 28VDC. AC or brownout fail is reported within 1 minute of event. To delay reporting for up to 6 hrs., cut “AC Delay” jumper and reset power to unit ( <i>Fig. 4f, pg. 6</i> ).
Bat Fail NC, C, NO	Used to indicate low battery condition, e.g. connect to alarm panel. Relay normally energized when DC power is present. Contact rating 1A @ 28VDC. A removed battery is reported within 1 minute. Battery reconnection is reported within 1 minute. Low battery threshold: approximately 21VDC ( <i>Fig. 4b, pg. 6</i> ).
– BAT +	Stand-by battery connections. Maximum charge current 3.6A ( <i>Fig. 4c, pg. 6</i> ).

### ACMS8 and ACMS8CB Access Power Controller

Terminal Legend	Function/Description
+ PWR1 –	Factory connected to AL1024ULXB2. Do not use these terminals.
+ PWR2 –	Factory connected to VR6 voltage regulator. Do not use these terminals.
+ INP1 – through + INP8 –	Eight (8) independently controlled Normally Open (NO), Normally Closed (NC), Open Collector Sink or Wet Input Triggers.
C, NC	FACP Dry NC output rated 1A/28VDC @ 0.6 Power Factor. Class 2 power-limited. With EOL JMP intact, will provide 10k resistance in a normal state.
GND, RST	FACP interface latching or non-latching. NO dry input. Class 2 power-limited. To be shorted for non-latching FACP interface or Latch FACP reset.
GND, EOL	EOL Supervised FACP Input terminals for polarity reversal FACP function. Class 2 power-limited.
– F, + F, – R, + R	FACP Signaling Circuit Input and Return terminals. Class 2 power-limited.
Output 1 through Output 8 NO, C, NC, COM	Eight (8) selectable independently controlled outputs [Fail-Safe (NC) or Fail-Secure (NO)] and eight (8) independently controlled Form “C” Relay outputs.

Fig. 6 - AL1024NKA8(D)



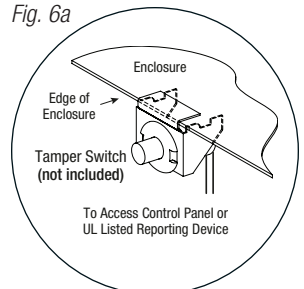
**CAUTION:** Use two (2) 12VDC stand-by batteries.

Keep power-limited wiring separate from non power-limited.  
Use minimum 0.25" spacing.

12AH Rechargeable batteries are the largest batteries that can fit in this enclosure.

A UL listed external battery enclosure must be used if using 40AH or 65AH batteries.

Fig. 6a







## Hook-Up Diagrams:

Fig. 8 - Daisy-chaining one or more ACMS8(CB) units.

EOL Jumper [EOL JMP] should be installed in the EOL position. **Non-Latching.**

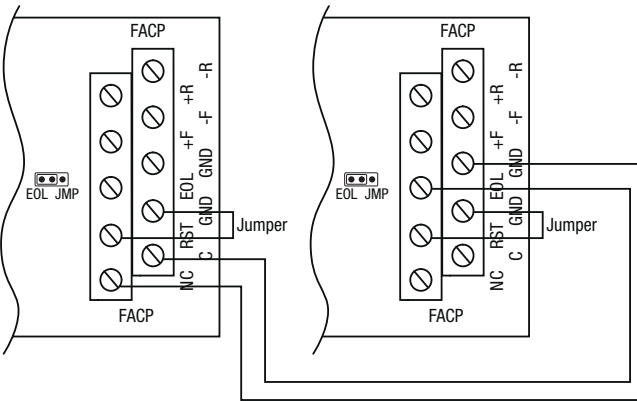


Fig. 9 - Daisy-chaining one or more ACMS8(CB) units.

EOL Jumper [EOL JMP] should be installed in the EOL position. **Latching Single Reset.**

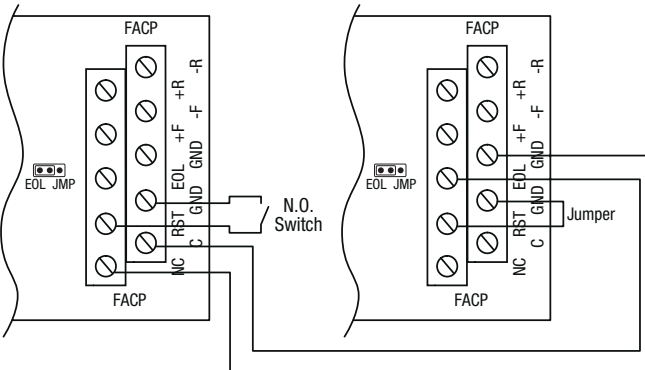
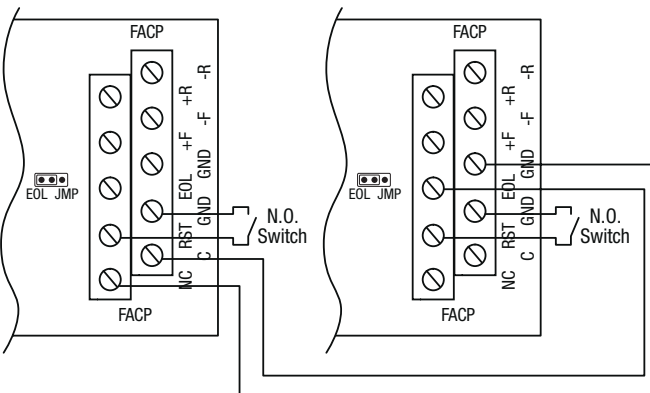


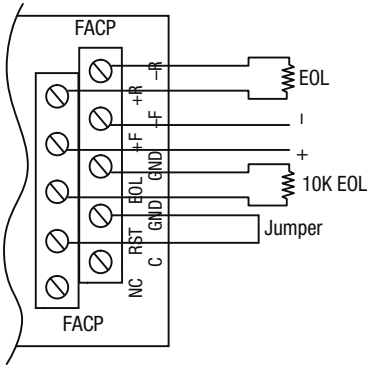
Fig. 10 - Daisy chaining one or more ACMS8(CB) units.

EOL Jumper [EOL JMP] should be installed in the EOL position. **Latching Individual Reset.**

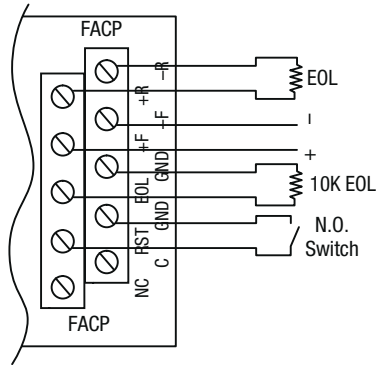


## Hook-Up Diagrams:

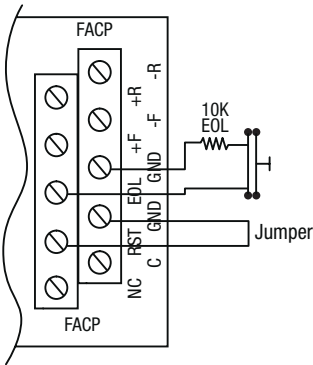
*Fig. 11 -* Polarity reversal input from FACP signaling circuit output (polarity is referenced in alarm condition).  
**Non-Latching.**



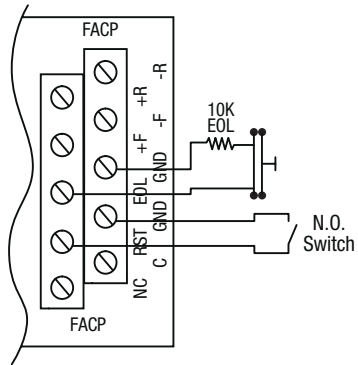
*Fig. 12 -* Polarity reversal input from FACP signaling circuit output (polarity is referenced in alarm condition).  
**Latching.**



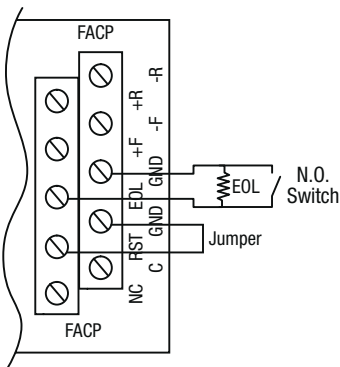
*Fig. 13 -* Normally Closed trigger input  
**(Non-Latching).**



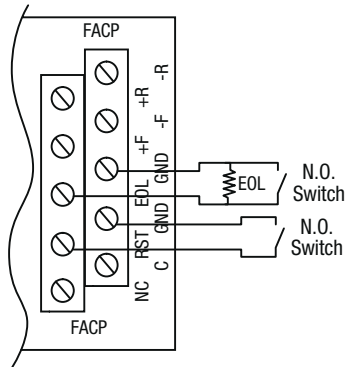
*Fig. 14 -* Normally Closed trigger input  
**(Latching).**



*Fig. 15 -* Normally Open trigger input  
**(Non-Latching).**

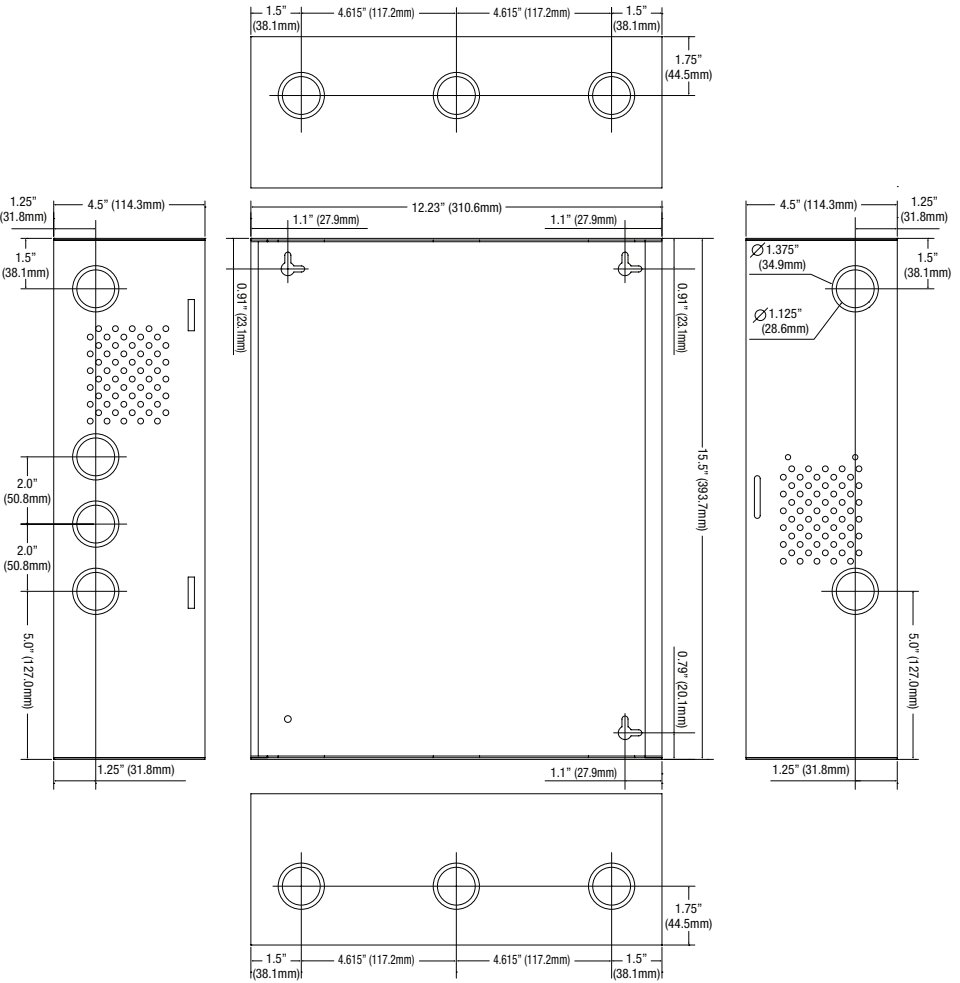


*Fig. 16 -* Normally Open trigger input  
**(Latching).**



# Enclosure Dimensions (BC400):

15.5" x 12" x 4.5" (393.7mm x 304.8mm x 114.3mm)



Altronix is not responsible for any typographical errors.

140 58th Street, Brooklyn, New York 11220 USA | phone: 718-567-8181 | fax: 718-567-9056  
 website: [www.altronix.com](http://www.altronix.com) | e-mail: [info@altronix.com](mailto:info@altronix.com) | Lifetime Warranty  
 IIAL1024NKA8(D) L01V



MEMBER