

4

3

2

1

REVISIONS				
ZONE	REV.	DESCRIPTION	DATE	APPROVED
	A	CMRM-01.2	26-APR-19	

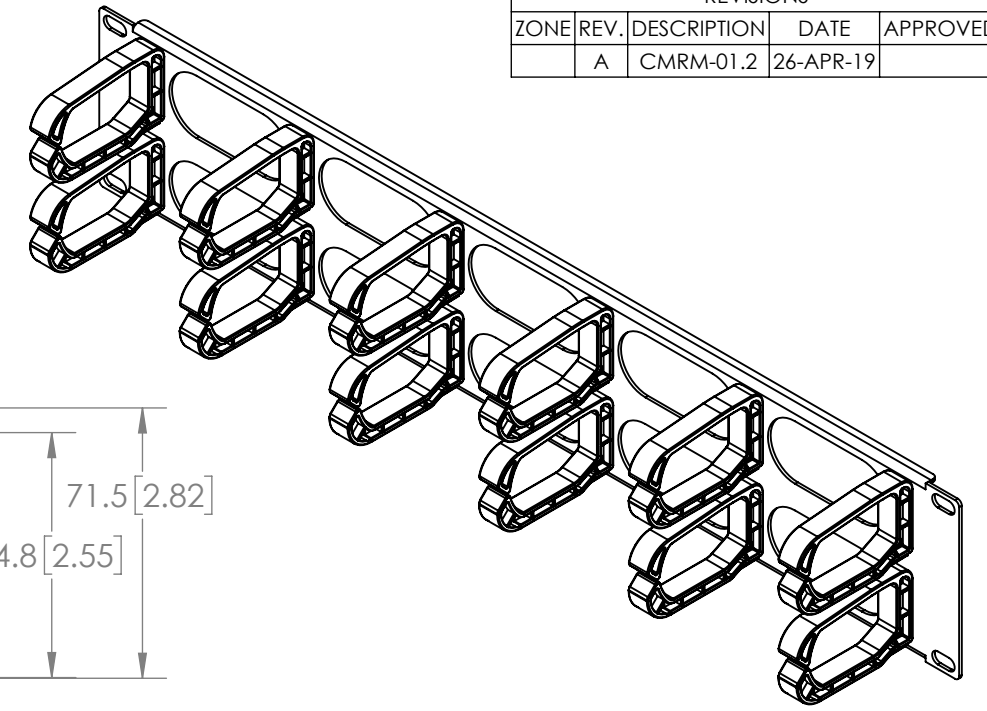

B

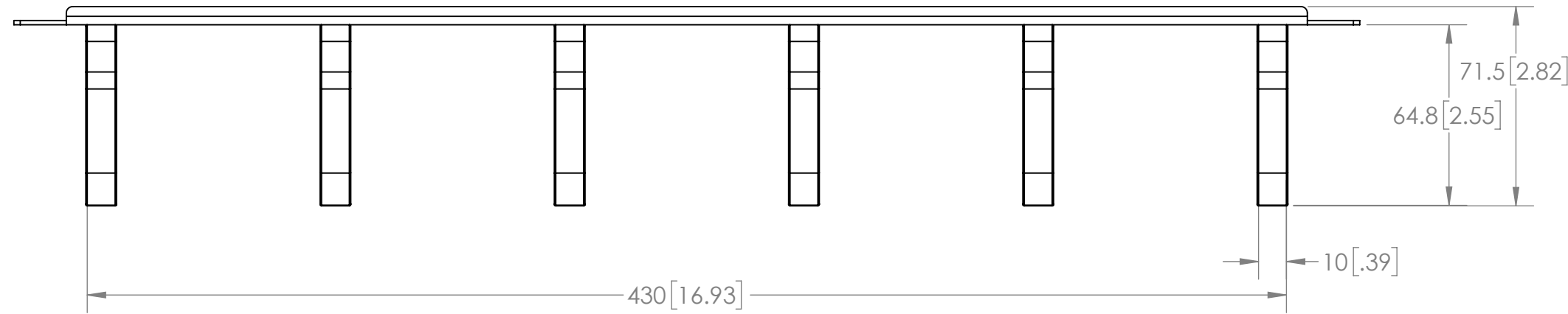

B

A

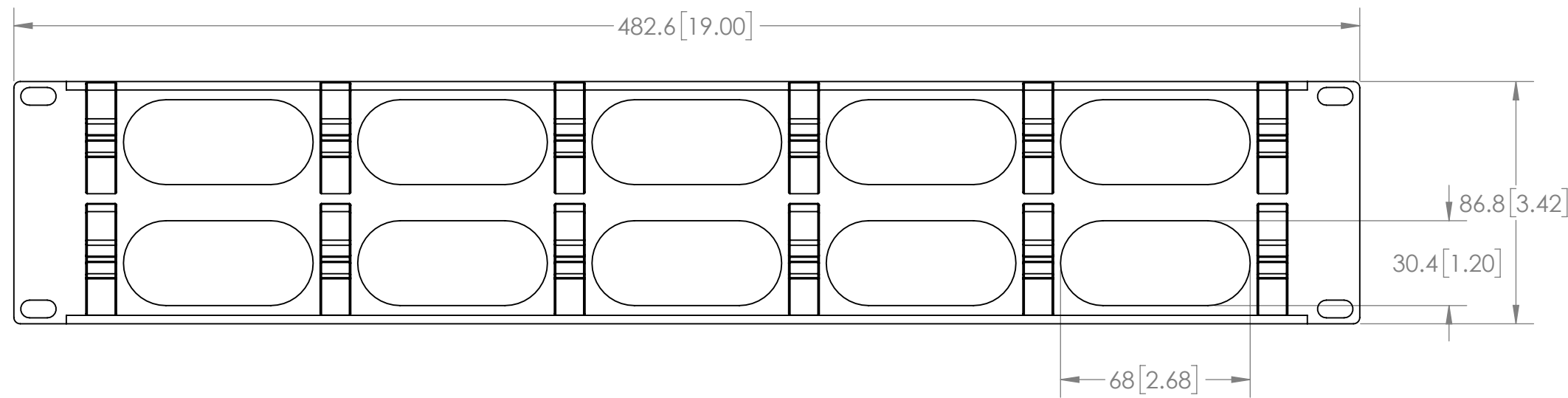

A

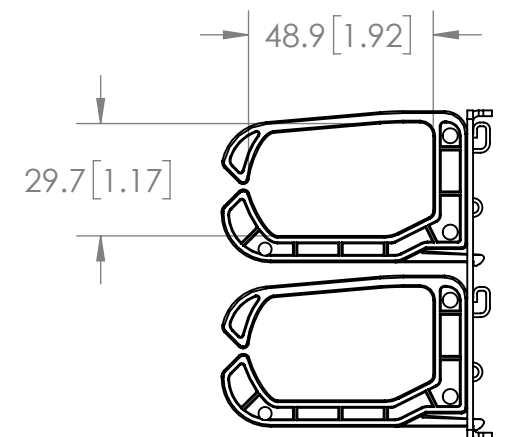

- NOTES:
- MATERIAL: 1.5-MM GALVANNEALED CARBON STEEL A653 OR EQUIVALENT
  - FINISH: BLACK POWDER COATING

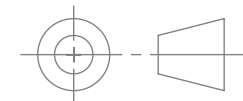

**PROPRIETARY AND CONFIDENTIAL**  
 THE INFORMATION CONTAINED IN THIS DRAWING IS THE SOLE PROPERTY OF SIGNAMAX, INC. ANY REPRODUCTION IN PART OR AS A WHOLE WITHOUT THE WRITTEN PERMISSION OF SIGNAMAX, INC. IS PROHIBITED.

UNLESS OTHERWISE SPECIFIED:		NAME	DATE	999 N.W. 159TH DRIVE, MIAMI, FL 33169, U.S.A.
DIMENSIONS ARE IN MM[IN]		DRAWN		
TOLERANCES:		CHECKED		TITLE CMRM-01.2 CBL MGT/RACK-MOUNT V.01/2 RMU
FRACTIONAL ±		ENG APPR.		
ANGULAR: MACH ± BEND ±		MFG APPR.		SIZE DWG. NO. B SPCS-PD.CMRM-01.2 A-AUG-18
TWO PLACE DECIMAL ±		Q.A.		
THREE PLACE DECIMAL ±		COMMENTS:	SEE NOTES	SCALE: 1:2 SHEET 1 OF 1
INTERPRET GEOMETRIC TOLERANCING PER:				
MATERIAL: SEE NOTES				
FINISH: SEE NOTES				
DO NOT SCALE DRAWING				

4

3

2

1