

Access & Power Integration

Altronix/Mercury Wired Kits

Models Include:

16 Door Kits with Fused Outputs:

T3M77XK1

Accommodates one (1) Intelligent Dual Reader Controller and seven (7) Dual Reader Interface Modules.

T3M77XK2

Accommodates one (1) Intelligent Dual Reader Controller and seven (7) Dual Reader Interface Modules.

T3M77XK3

Accommodates up to eight (8) Dual Reader Interface Modules.

Each fully assembled kit includes:

- Trove3 enclosure with TM3 Altronix/Mercury/LeneIS2 backplane
- Two (2) eFlow104NB - Power Supply/Chargers
- Two (2) ACMS8 - Dual Input/Output Fuse Protected Access Power Controllers
- Two (2) VR6 - Voltage Regulators
- Two (2) PDS8 - Dual Input/Output Fuse Protected Power Distribution Modules
- One (1) Rocker Switch Bracket with Two (2) Rocker Switches (Not evaluated by UL)
- Wire harnesses and finger duct

16 Door Kits with PTC Outputs:

T3M77XK1D

Accommodates one (1) Intelligent Dual Reader Controller and seven (7) Dual Reader Interface Modules.

T3M77XK2D

Accommodates one (1) Intelligent Dual Reader Controller and seven (7) Dual Reader Interface Modules.

T3M77XK3D

Accommodates up to eight (8) Dual Reader Interface Modules.

Each fully assembled kit includes:

- Trove3 enclosure with TM3 Altronix/Mercury/LeneIS2 backplane
- Two (2) eFlow104NB - Power Supply/Chargers
- Two (2) ACMS8CB - Dual Input/Output PTC Protected Access Power Controllers
- Two (2) VR6 - Voltage Regulators
- Two (2) PDS8CB - Dual Input/Output PTC Protected Power Distribution Modules
- One (1) Rocker Switch Bracket with Two (2) Rocker Switches (Not evaluated by UL)
- Wire harnesses and finger duct

All components of this Trove kit are UL Listed sub-assemblies.

Please refer to the included corresponding Sub-Assembly Installation Guides for further information.

Installation Guide



More than just power.TM

All registered trademarks are property of their respective owners.

Rev. T3M77XK012121

Installing Company: _____ Service Rep. Name: _____

Address: _____ Phone #: _____

Overview:

Altronix Trove Plus kits are pre-wired, pre-assembled and consist of Trove3M3 enclosure/backplane with factory installed Altronix power supply/charger(s) and sub-assemblies, wire harnesses and finger duct.

Configuration Chart:

Altronix Model Number	120VAC 60Hz Input Current (A)	Power Supply Board Input Fuse Rating	Power Supply Board Battery Fuse Rating	Nominal DC Output Voltage				Maximum Supply Current for Main and Aux. Outputs on Power Supply board and ACMS8(CB) Access Power Controller's outputs	Fail-Safe/Fail-Secure or Dry Form "C" Outputs	Current Per ACMS8 and PDS8(CB) Output (A)	ACMS8(CB) Board Input Fuse (PTC) Rating	ACMS8(CB) Board Output Fuse (PTC) Rating	PDS8(CB) Board Input Fuse (PTC) Rating	PDS8(CB) Board Output Fuse (PTC) Rating
				Power Supply 1		Power Supply 2								
				[DC]	[Aux]	[DC]	[Aux]							
T3M77XK1	9	6.3A/250V	15A/32V	Output Range (VDC)	Output Range (VDC)	Output Range (VDC)	Output Range (VDC)	24VDC @ 9.4A	16	2.5	15A/32V	3A/32V	10A/32V	3A/32V
T3M77XK2				20.17-26.4	20.28-26.4	20.17-26.4	20.28-26.4							
T3M77XK3														
T3M77XK1D														
T3M77XK2D														
T3M77XK3D														

Hardware and Accessories:

- Two (2) tamper switches (Altronix Model TS112 or equivalent).
- Cam lock.
- Battery leads.

Mechanical:

- 16 Gauge enclosure with ample knockouts for convenient access.
- Enclosure Dimensions (H x W x D): 36.12" x 30.125" x 7.06" (917.5mm x 768.1mm x 179.3mm).

Installation Instructions:

Wiring methods shall be in accordance with the National Electrical Code/NFPA 70/ANSI, and with all local codes and authorities having jurisdiction. Product is intended for indoor use only.

1. Remove backplane from enclosure. Do not discard hardware.
2. Mark and predrill holes in the wall to line up with the top three keyholes in the enclosure. Install three upper fasteners and screws in the wall with the screw heads protruding. Place the enclosure's upper keyholes over the three upper screws, level and secure. Mark the position of the lower three holes. Remove the enclosure. Drill the lower holes and install the three fasteners. Place the enclosure's upper keyholes over the three upper screws. Install the three lower screws and make sure to tighten all screws.
3. Mount included UL Listed tamper switches (Altronix Model TS112 or equivalent) in desired location, opposite hinge. Slide the tamper switch bracket onto the edge of the enclosure approximately 2" from the right side (*Fig. 1, pg. 2*). Connect tamper switch wiring to the Access Control Panel input or the appropriate UL Listed reporting device. To activate alarm signal open the door of the enclosure.
4. Mount Mercury boards to backplane, refer to *pg. 3, 4*.
5. Refer to the *eFlow Power Supply/Charger Installation Guide* for eFlow104NB and corresponding *Sub-Assembly Installation Guides* for PDS8(CB) and ACMS8(CB) for further installation instructions.
6. Position Lenel/Mercury access controller module over corresponding spacers and depress onto snap on spacers (*Fig. 2-4, pg. 3-5*).
7. Mount backplane to enclosure with hardware.

Fig. 1

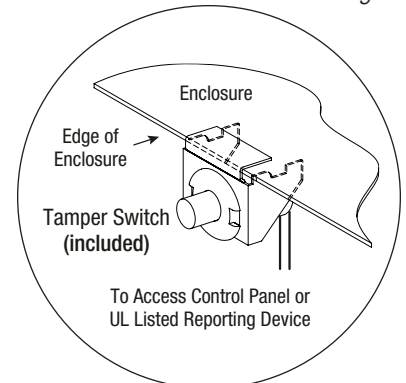

T3M77XK1 (T3M77XK1D) Configuration:

1. Position access controller module over corresponding spacers and depress onto snap on spacers (Fig. 2, pg. 3).
2. Mount backplane to enclosure with hardware.

Access Controller Position Chart for the Following Models:

LenelS2 / Mercury Access Controller LNL-2220 / LP1502 LNL-1320 / MR52	Pem Mounting (A) (B) (C) (D) (E) (F) (G) (H)
--	---

Fig. 2

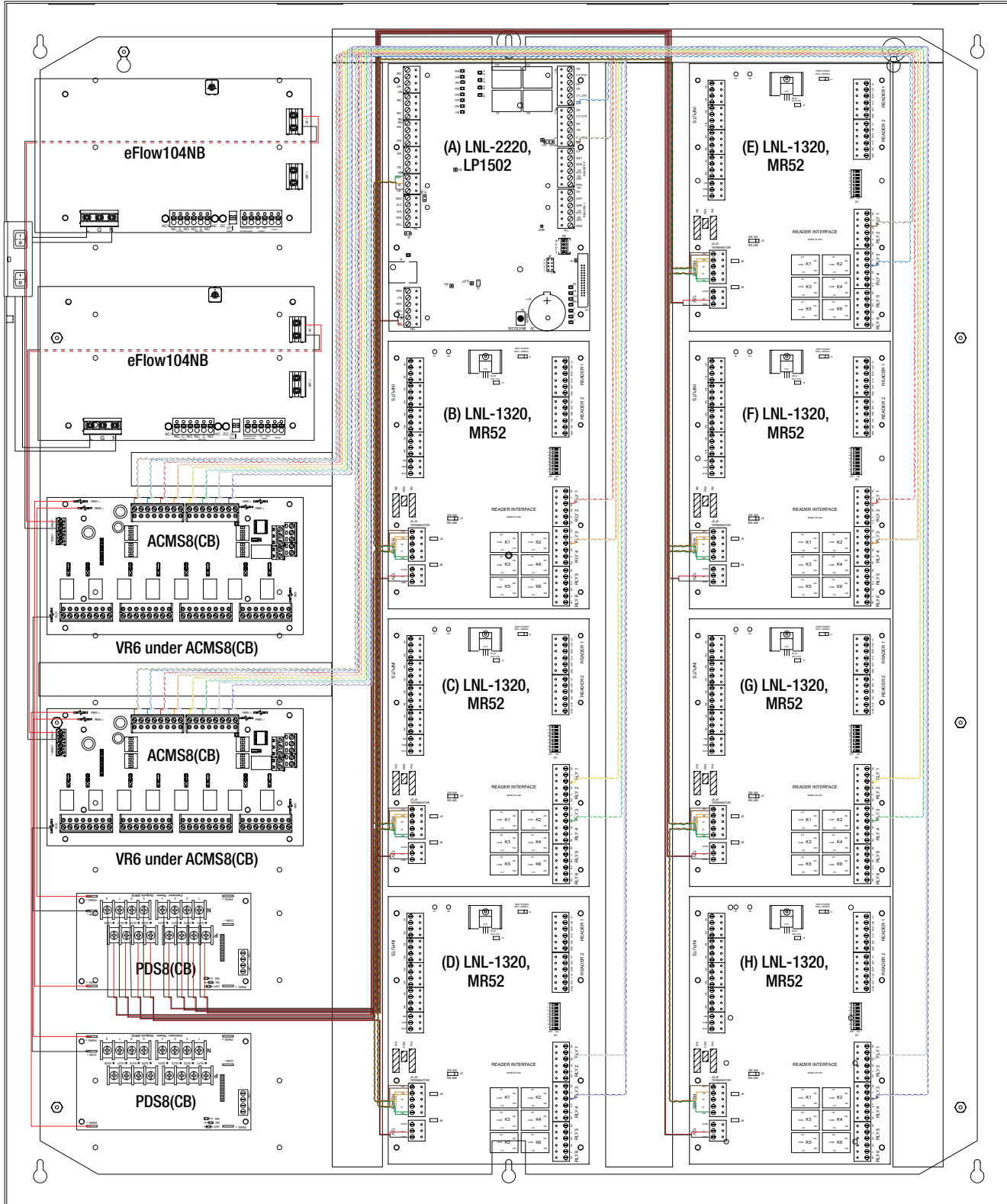

T3M77XK2 (T3M77XK2D) Configuration:

1. Position access controller module over corresponding spacers and depress onto snap on spacers (Fig. 3, pg. 4).
2. Mount backplane to enclosure with hardware.

Access Controller Position Chart for the Following Models:

LenelS2 / Mercury Access Controller LNL-3300 / LP2500 LNL-1320 / MR52	Pem Mounting (A) (B) (C) (D) (E) (F) (G) (H)
--	---

Fig. 3

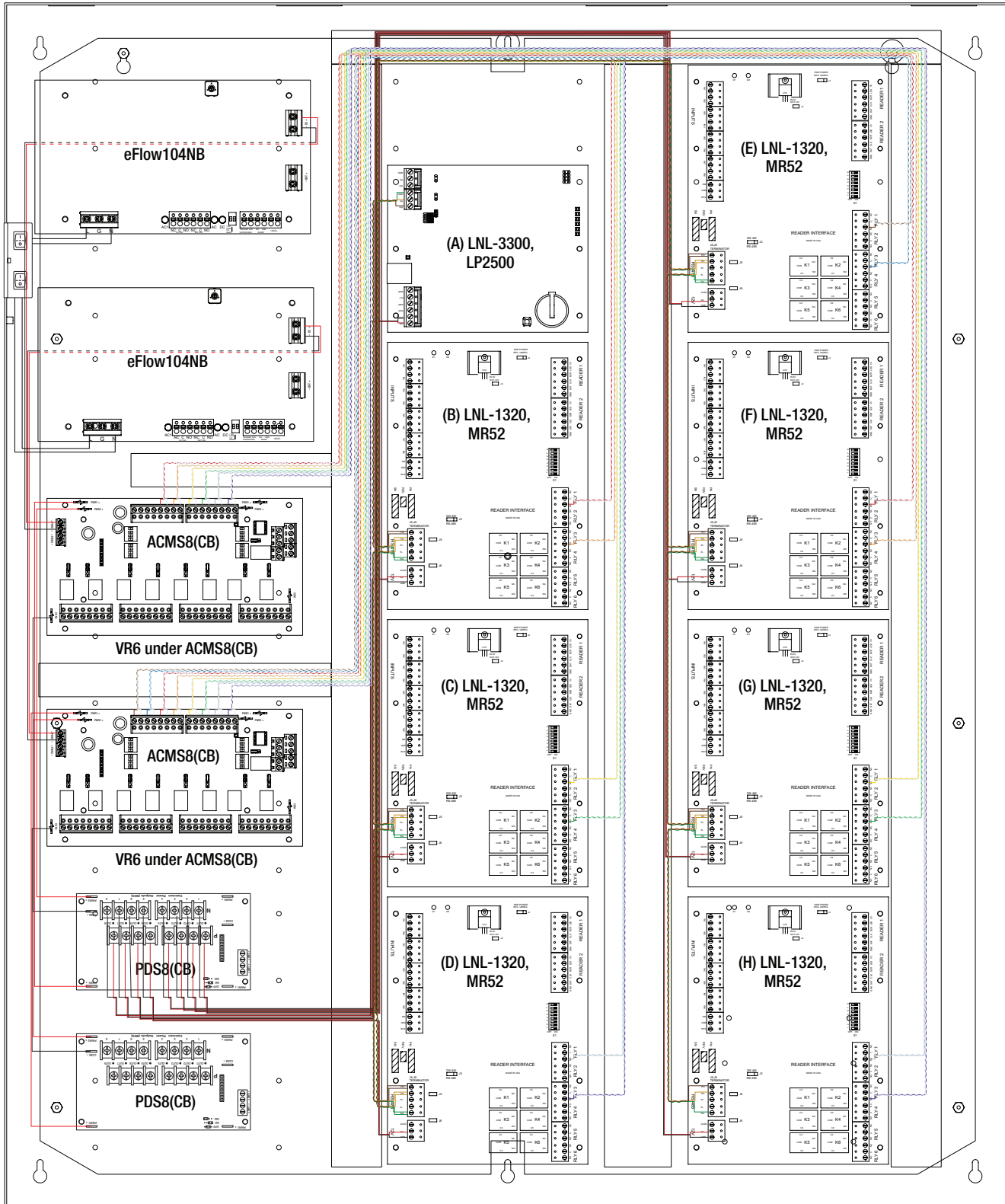

T3M77XK3 (T3M77XK3D) Configuration:

1. Position access controller module over corresponding spacers and depress onto snap on spacers (Fig. 4, pg. 5).
2. Mount backplane to enclosure with hardware.

Access Controller Position Chart for the Following Models:

LenelS2 / Mercury Access Controller LNL-1320 / MR52	Pem Mounting (A) (B) (C) (D) (E) (F) (G)
---	--

Fig. 4

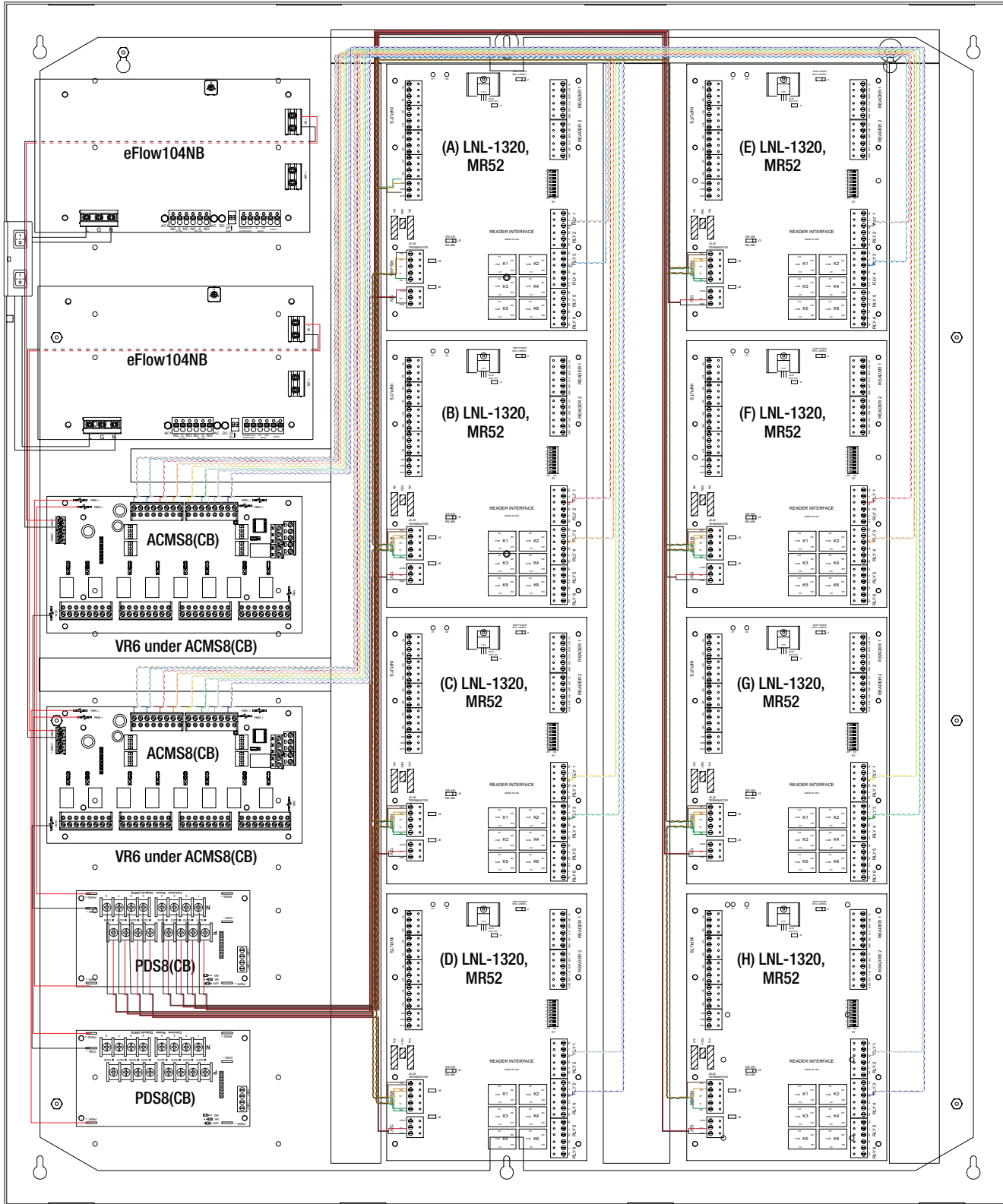



eFlow Power Supply/Chargers can be Controlled and Monitored while Reporting Power/Diagnostics from Anywhere over the Network...

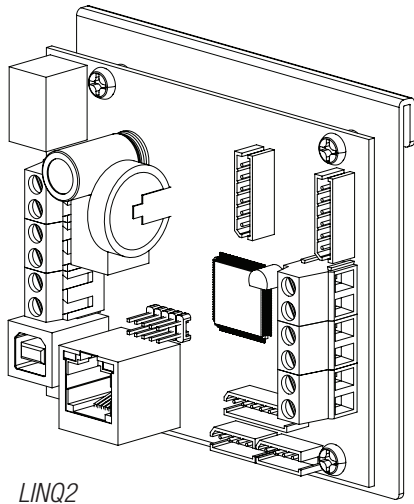

LINQ2

LINQ™

LINQ2 - Network Communication Module

LINQ2 provides remote IP access to real-time data from eFlow power supply/chargers to help keep systems up and running at optimal levels. It facilitates fast and easy installation and set-up, minimizes system downtime, and eliminates unnecessary service calls, which helps reduce Total Cost of Ownership (TCO) - as well as creating a new source of Recurring Monthly Revenue (RMR).

Features:

- UL Listed in the U.S. and Canada.
- Local or remote control of up to (2) two Altronix eFlow power output(s) via LAN and/or WAN.
- Monitor real time diagnostics: DC output voltage, output current, AC & battery status/service, input trigger state change, output state change and unit temperature.
- Access control and user management: Restrict read/write, Restrict users to specific resources
- Two (2) integral network controlled Form "C" Relays.
- Three (3) programmable input triggers: Control relays and power supplies via external hardware sources.
- Email and Windows Dashboard notifications
- Event log tracks history.
- Secure Socket Layer (SSL).
- Programmable via USB or web browser - includes operating software and 6 ft. USB cable.

LINQ2 Mounts Inside any Trove Enclosure

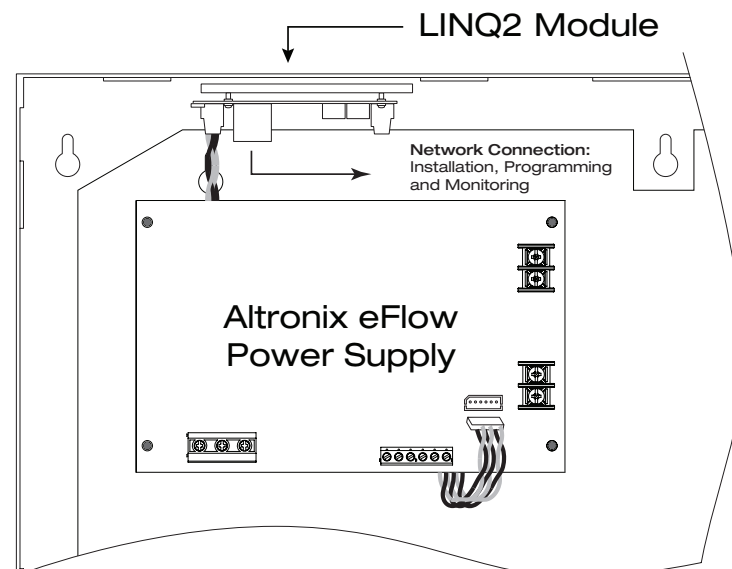

TM3 Dimensions

34" x 28" x 0.3125" (863.6mm x 711.2mm x 7.9mm)

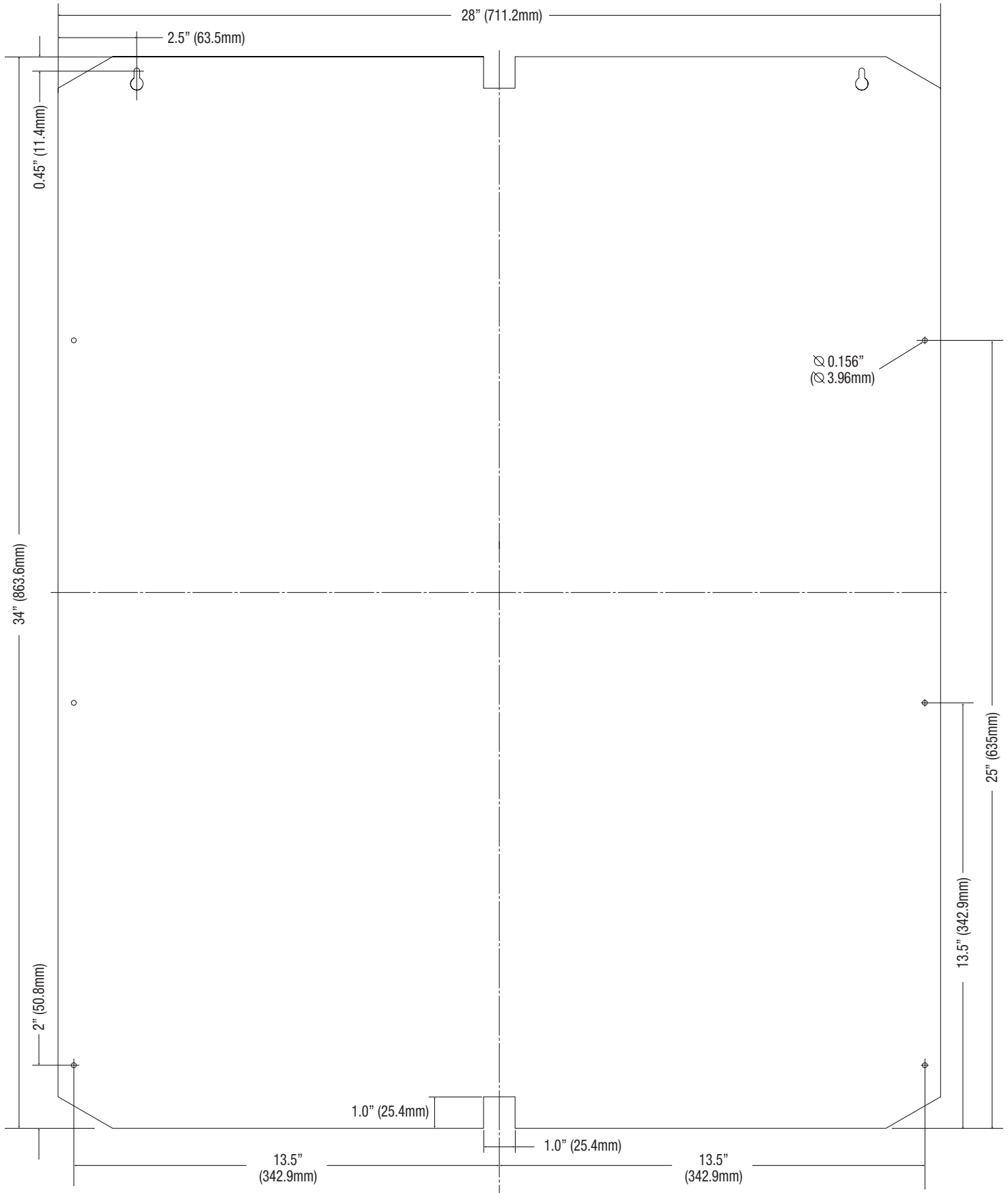

Trove3 Enclosure Dimensions (H x W x D approximate):

36.12" x 30.125" x 7.06" (917.5mm x 768.1mm x 179.3mm)

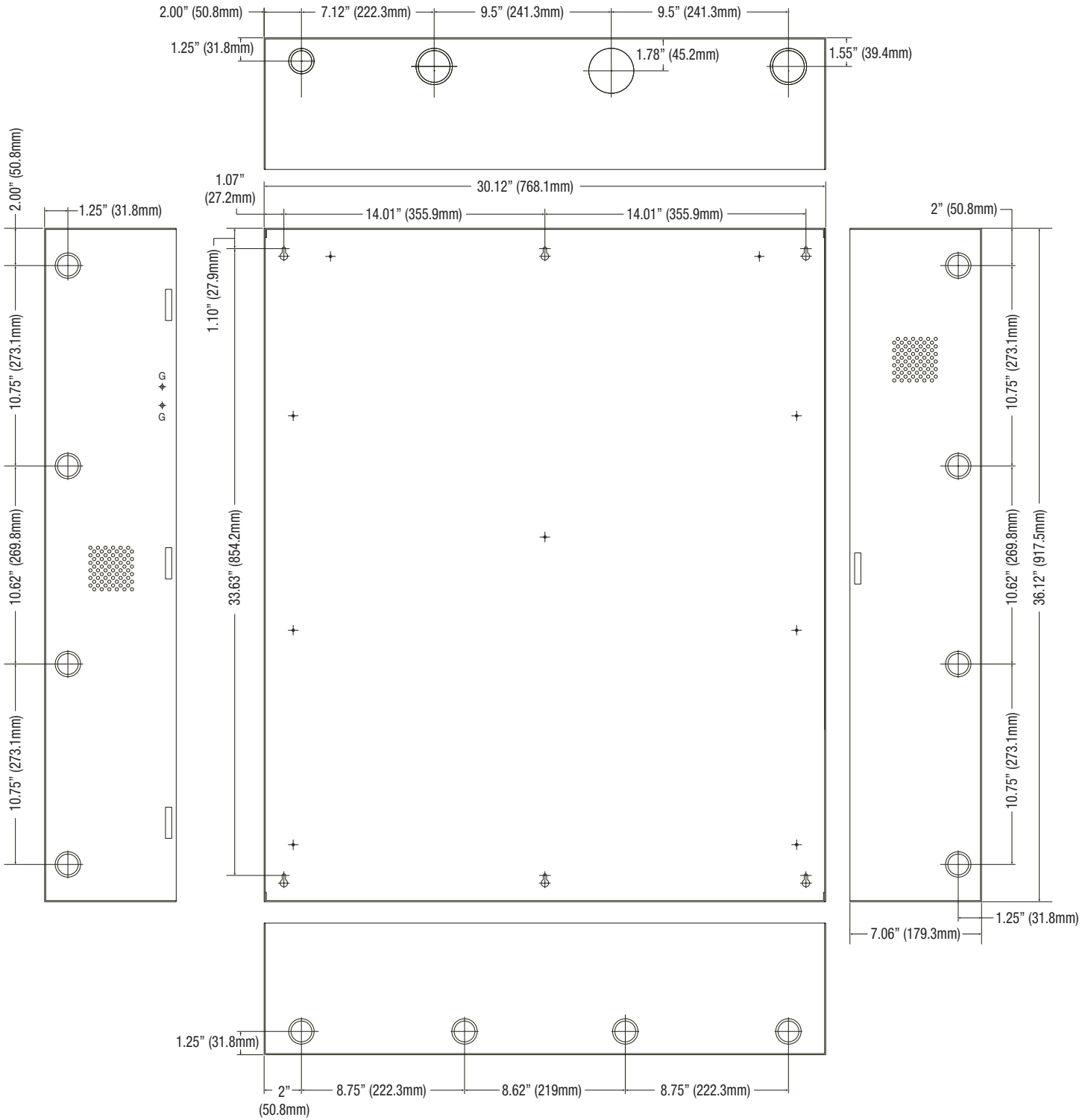

Altronix is not responsible for any typographical errors.

140 58th Street, Brooklyn, New York 11220 USA | phone: 718-567-8181 | fax: 718-567-9056
 web site: www.altronix.com | e-mail: info@altronix.com | Lifetime Warranty
 IIT3M77XK Kit Series

JO4U

