

Bill of Material					
ITEM	PART NUMBER	QTY	DESCRIPTION	FILE NAME	REVISION
1	-	1	19" EIA SLIDING SHELF, 26" DEEP WELDMENT	I0008 11.iam	1
2	31241650	2	SLIDE, 16", 17 1/2" TRAVEL, BAYONET ATTACHMENT, DISCONNECT	3124 1650.iam	-
3	7206FRSLADX104	2	MOUNTING CHANNEL - 19" & 23" EIA SLIDING SHELF, 26" DEEP	I0008 09.iam	4
4	-	4	#8-32 x 1/4" L PAN HEAD PHIL TYPE 23 SCREW, ZINC PLATED	SCR832X250BLK.ipt	-
5	7206FRSLADX102	4	MOUNTING TAB FOR FRSLAD SHELVES	I0004 61.ipt	5
6	SCR1032X1/2BLK	4	#10-32 x 1/2" L PAN HEAD PHIL TYPE 23, BLACK	SCR1032X500BLK.ipt	-

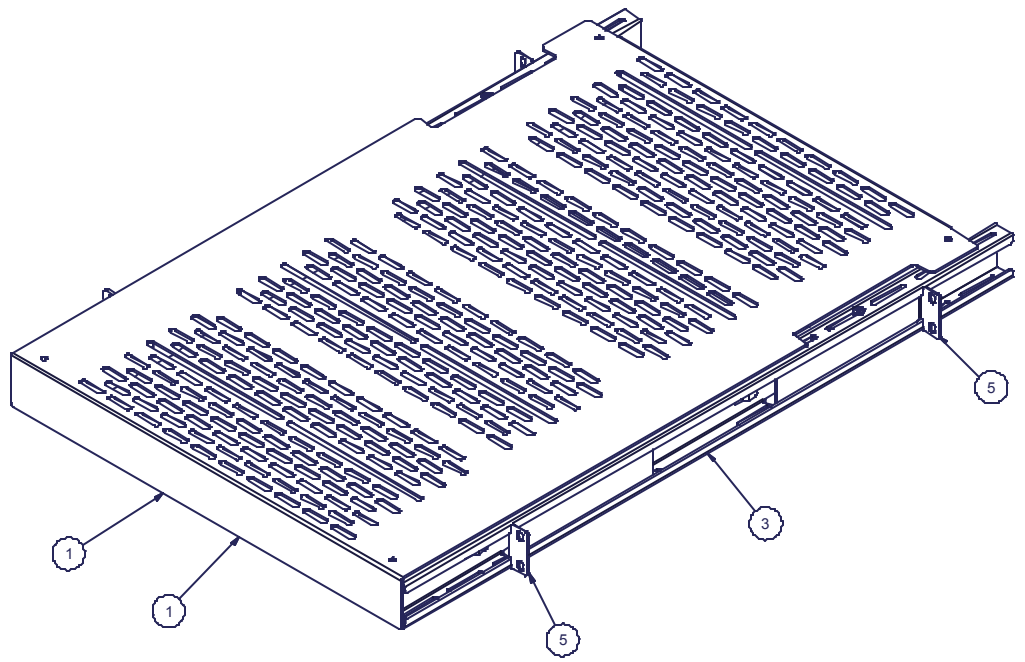
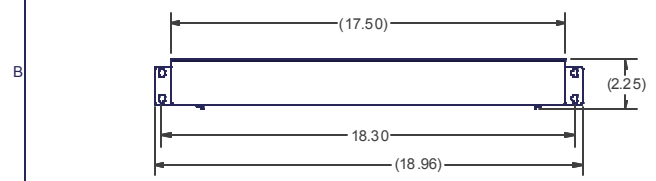
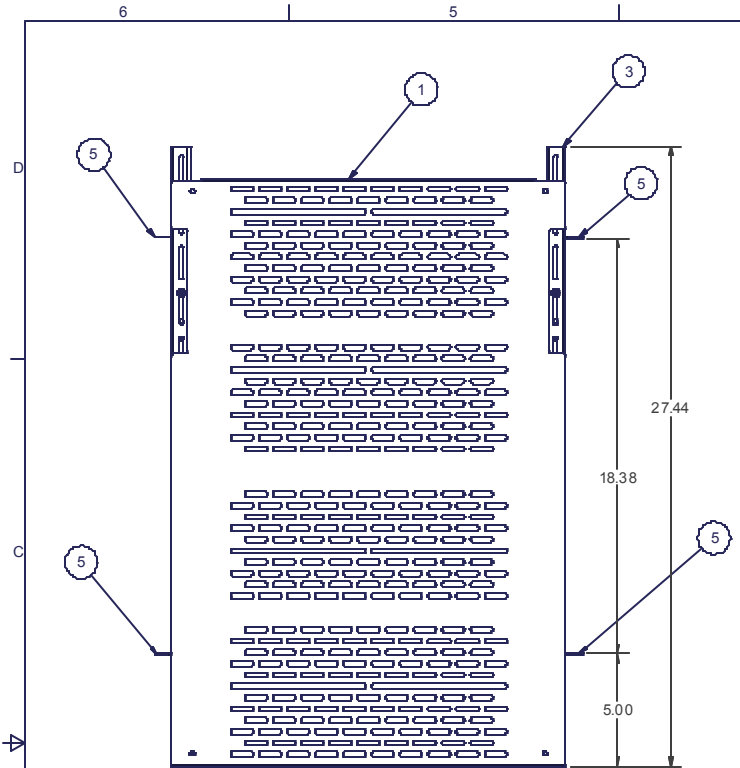

SHELF SPECIFICATIONS:
 - 19" EIA RACK MOUNTING
 - MAX TAB PLACEMENT: 32 1/8"
 - WEIGHT CAPACITY: 110#
 - SLIDE TRAVEL: 17 1/2"

INTERPRET DRAWING PER ASME Y14.5M-1994
 DIMENSIONAL LIMITS APPLY
 AFTER APPLICATION OF FINISH
 DRAWING NOT TO SCALE
 TOLERANCE UNLESS OTHERWISE NOTED:
 ANGULAR +/- .1
 .XXXX +/- .010
 .XXX +/- .015
 .XX +/- .030
 X FOR REF. ONLY
 UNLESS OTHERWISE SPECIFIED
 ALL DIMENSIONS ARE IN INCHES

NOTICE:
 Use of this document is subject to a confidentiality and nondisclosure agreement with Great Lakes Case & Cabinet Co., Inc. (GLCC) and may not be reproduced, disclosed or utilized in whole or in part without prior written authorization from GLCC.

PART NUMBER:
7206FRSLADHD
 QTY PER UNIT: 1
 MATERIAL TYPE: N/A
 MATERIAL GAUGE: #16GA
 FINISH: N/A
 DRAWS: WSS 9/19/02
 CHECKED: -

TITLE: SHELF, SLIDING ADJUSTABLE, 19" EIA, 26" DEEP
 GREAT LAKES CASE & CABINET CO., INC.
 P.O. BOX 551 EDINBORO, PA 16412
 PHONE (814) 734-7303 FAX (814) 734-3907
 E-MAIL glcc@greatcabinets.com
 DWG NO: 1000807
 REV: 5
 SHEET 1 OF 2

ASSEMBLY NOTES:

- 1) DISCONNECT THE INNER AND OUTER MEMBER OF ITEM #2 (SLIDE).
- 2) ATTACH THE INNER AND OUTER MEMBERS OF ITEM #2 (SLIDE) AS SHOWN (TYPICAL BOTH SIDES OF SHELF).
- 3) SLIDE ITEM #5 (MOUNTING TAB) INTO ITEM #3 (CHANNEL) ORIENT AS SHOWN. SECURE EACH WITH TWO ITEM #4 SCREWS.

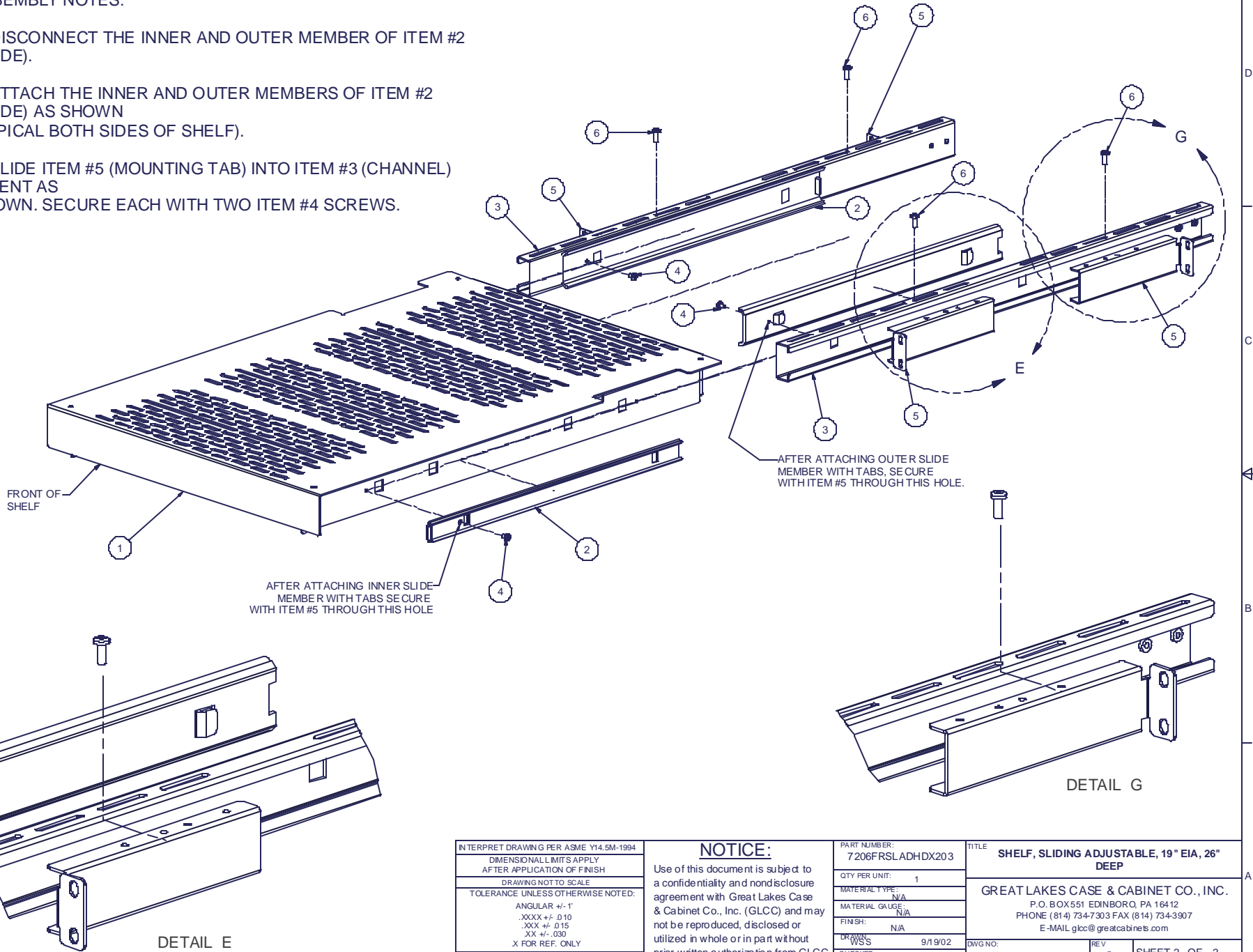

INTERPRET DRAWING PER ASME Y14.5M-1994 DIMENSIONAL LIMITS APPLY AFTER APPLICATION OF FINISH DRAWING NOT TO SCALE TOLERANCE UNLESS OTHERWISE NOTED: ANGULAR $\pm .1^\circ$.XXXX $\pm .010$.XXX $\pm .015$.XX $\pm .030$ X FOR REF. ONLY
UNLESS OTHERWISE SPECIFIED ALL DIMENSIONS ARE IN INCHES

NOTICE:
 Use of this document is subject to a confidentiality and nondisclosure agreement with Great Lakes Case & Cabinet Co., Inc. (GLCC) and may not be reproduced, disclosed or utilized in whole or in part without prior written authorization from GLCC.

PART NUMBER:	7206FRSLADHDX203
QTY PER UNIT:	1
MATERIAL TYPE:	N/A
MATERIAL GAUGE:	N/A
FINISH:	N/A
DATE:	9/19/02
CHECKED:	-

TITLE	SHELF, SLIDING ADJUSTABLE, 19" EIA, 26" DEEP		
	GREAT LAKES CASE & CABINET CO., INC. P.O. BOX 551 EDINBORO, PA 16412 PHONE (814) 734-7303 FAX (814) 734-3907 E-MAIL glcc@greatcabinets.com		
DWG NO:	1000807	REV	5
			SHEET 2 OF 2