

Single-Pole and 3-Way with 3-Way Switch Application Wide-View Motion Activated Light Control



Cat. Nos. DOS05, DVS05 - INDOOR USE ONLY

Ratings: 120VAC, 60Hz, 600 W Incandescent/Halogen, 5 A Resistive, 300 W LED and CFL, 400 VA ELV/MLV, 1/4 HP Motor

WARNINGS

- **TO AVOID FIRE, SHOCK OR DEATH: TURN OFF POWER AT CIRCUIT BREAKER OR FUSE AND TEST THAT THE POWER IS OFF BEFORE WIRING!**
- **TO AVOID PERSONAL INJURY OR PROPERTY DAMAGE, DO NOT** install to control a receptacle, or a load in excess of the specified rating.
- To be installed and/or used in accordance with electrical codes and regulations.
- If you are not sure about any part of these instructions, consult an electrician.

CAUTIONS

- To avoid damage to the product, **DO NOT** use disinfecting products, including foggers, sprays or other types of atomized cleaning agents.
- **DO NOT** spray liquid onto the product.
- To clean, use a damp cloth with mild soap.
- No user-serviceable components. **DO NOT** attempt to service or repair.
- Use this device **WITH COPPER OR COPPER-CLAD WIRE ONLY**.

PK-A3346-10-00-2B AR1323

INSTALLATION INSTRUCTIONS

ENGLISH

Features

- Cat. Nos. DOS05 and DVS05 have a sensing angle of 180° and a sensing area of coverage of 30 ft. x 30 ft. See coverage diagram for details.
- Adjustable ambient light (DOS05 only), time delay, and area of coverage controls. See adjustment setting section for details.
- Indicator lights alert the user to the device's status.
- Adjustable time delay setting for 1, 5, 10 and 20 minutes plus a test mode with 5 seconds on. A Temporary Bypass mode that disables the Auto-on feature is available only for DOS05.
- Color change kits are available in white, light almond, ivory, black, brown, and gray.

NOTE: Also available for single-pole only (cat. nos. DOS02/DVS02) and multi-way or multi-sensor (cat. nos. DOS15/DVS15)

Mounting Location

- The device responds to temperature changes and care should be taken when mounting the device.
- **DO NOT** mount directly above a heat source, in a location where hot or cold drafts will blow directly on the sensor, or where unintended motion (e.g., hallway traffic) will be within sensor's field-of-view.

You Will Need:

- Slotted/Phillips screwdriver
- Electrical tape
- Cutters
- Pliers

Installation

WARNING: TO AVOID FIRE, SHOCK OR DEATH, turn OFF power at circuit breaker or fuse and test that the power is OFF before wiring.

1. Identify your wires (most common):

NOTE: Neutral wire (if present), or a Ground wire is required for operation. If the wiring in the wallbox does not resemble this configuration, consult an electrician.

Single-Pole

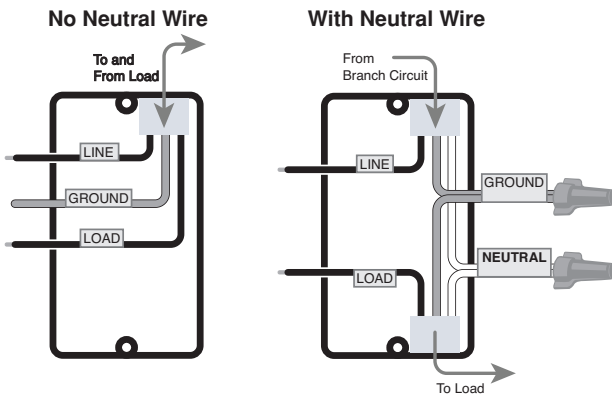

3-Way (Neutral NOT Present)

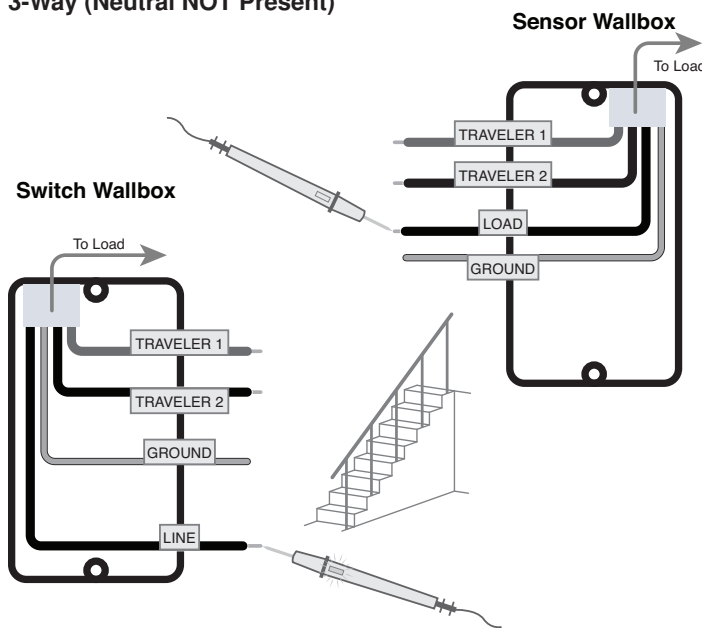

OR

3-Way (Neutral Present)

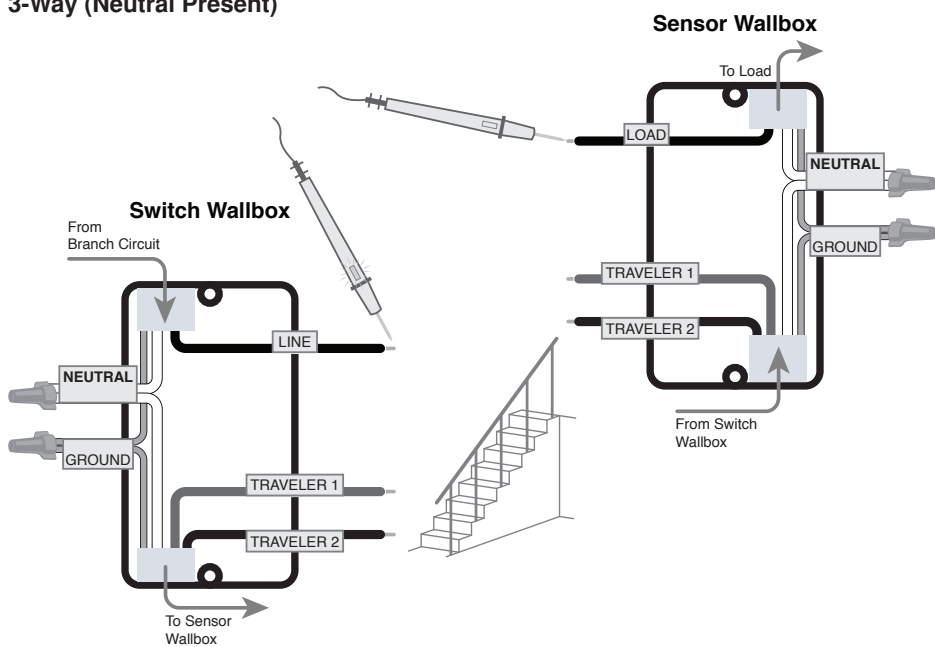

NOTE: Sensor must be installed in the location where the load wire is.

2a. Wire (when Neutral is NOT present).

Working on one connection at a time, connect wires as shown.

NOTE: This device is designed so the line and load wires can be wired interchangeably.

Single-Pole

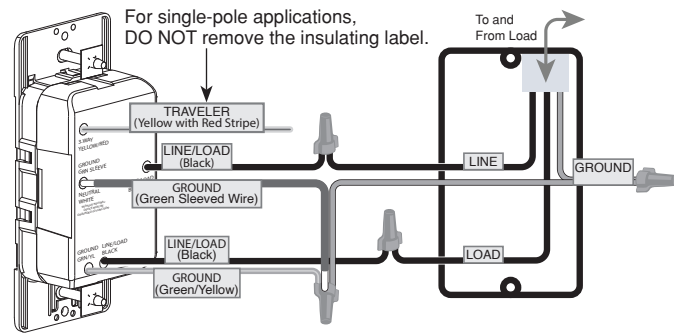

3-Way

NOTE: To control the load from the 3-way switch, toggle once to turn the load ON and twice to turn the load OFF.

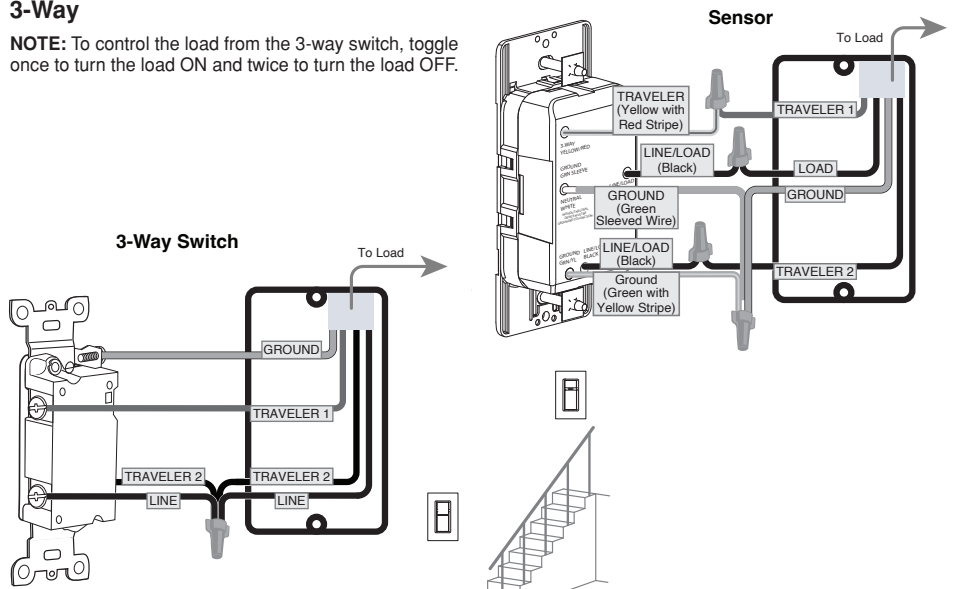

2b. Wire (when Neutral is present).

Remove the GREEN sleeve from the white wire. Working on one connection at a time, connect wires as shown.

NOTE: This device is designed so the line and load wires can be wired interchangeably.

Single-Pole

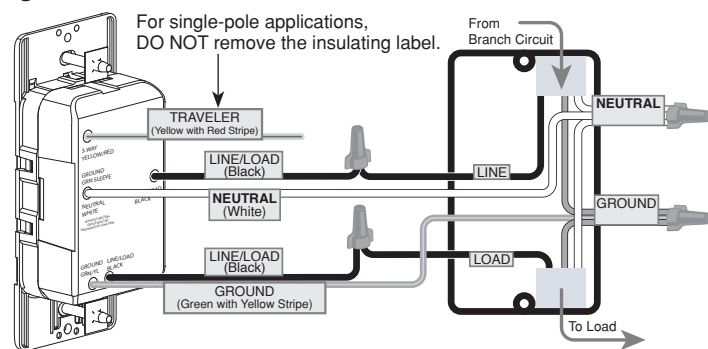

3-Way

NOTE: To control the load from the 3-way switch, toggle once to turn the load ON and twice to turn the load OFF.

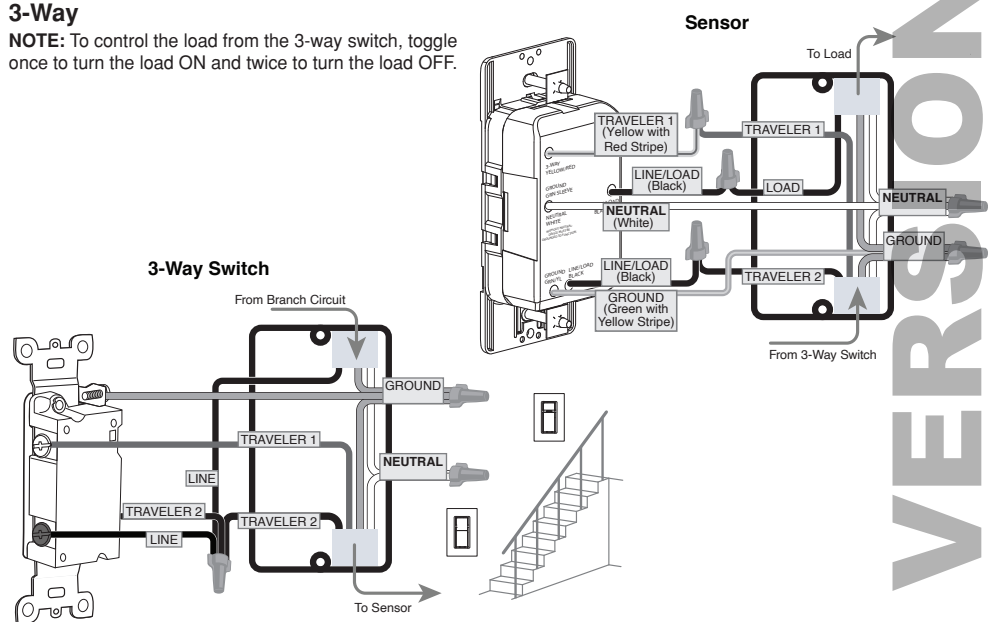

3. Test and mount.

- Restore power. Wait 10-20 seconds for sensor to power up.
- DOS05: lights automatically turn ON with first motion seen after warm up period, or when the button is pushed.
- DVS05: Lights will turn ON when button is pressed.
- **NOTE:** If lights do not turn ON, refer to the "What to do if..." section.
- **Turn OFF power at circuit breaker before completing the installation.**
- Gently push wires into wallbox. Screw light control to box.
- Install wallplate.
- Restore power.

WEB VERSION

Operation

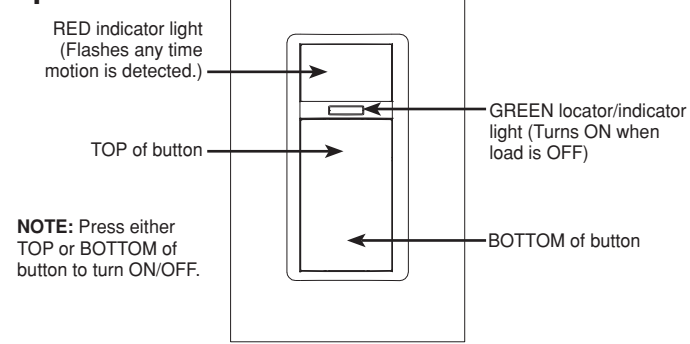

Programming

The table below describes each setting and each option within that setting. When in the Program mode, the sensor's LEDs blink a red or green light sequence to verify the settings you selected. For example, if you select the Light Timer setting, the Red LED blinks two times. If you want to set the light timer to 5 minutes, the Green LED blinks two times.

Setting Types and Options (defaults are in bold)			
Option Number	Setting 1 TIMER (Duration of time for which load is ON since last detected motion.)	Setting 2 SENSITIVITY (Sensitivity to motion – adjusting the major and minor detection range.)	Setting 3 DOS05 only - AMBIENT LIGHT (If the room is brighter than the setting selected, the load will not turn ON.)
Option 1 (1 blink)	1 minute	Low (50% Range)	Low Light level
Option 2 (2 blinks)	5 minutes	Medium	Medium Light level
Option 3 (3 blinks)	10 minutes	High	High/Brightest light level
Option 4 (4 blinks)	20 minutes	All settings to default	Disabled – Turns ON for all light levels

NOTE: Temporary Disable (DOS05 Occupancy Sensor only).

1. Enter Programming Mode. Make sure the load is ON.

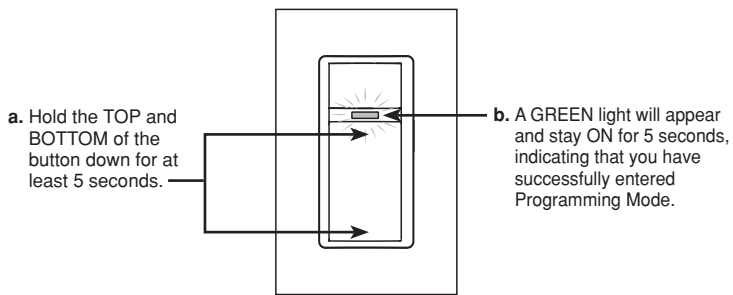

2. Select each setting you want to change, one at a time, to program the option desired (see table above).

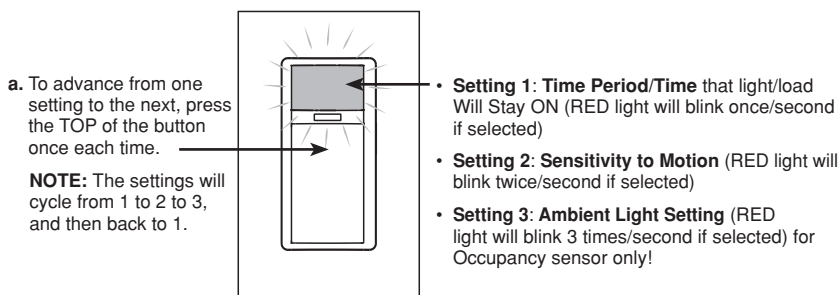

NOTE: Once you enter Programming Mode, multiple settings can be changed before saving and exiting.

3. Change the option within each setting (see the table above for the options). **NOTE:** The default option for each setting is listed in the table in bold.

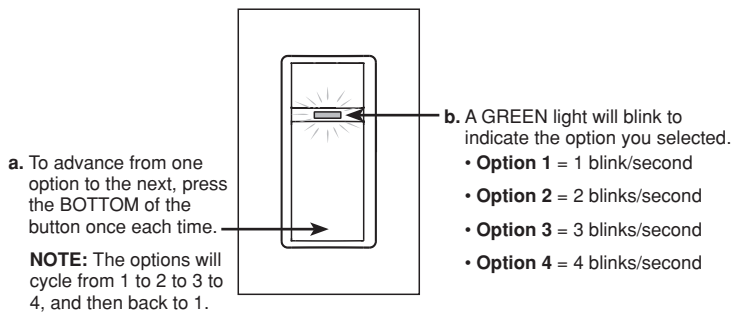

4. Save your settings and exit the Programming Mode.

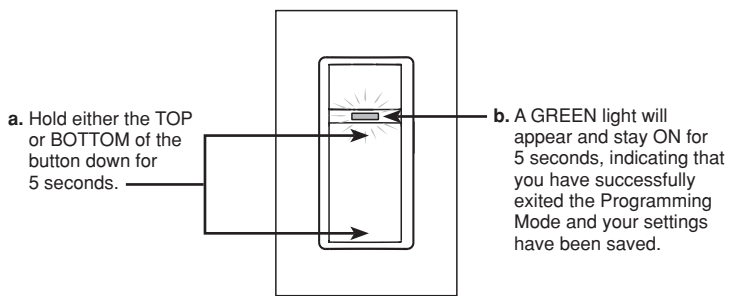

NOTES:

- After 30 seconds of inactivity, the device will automatically exit Programming Mode and setting changes will not be saved.
- When you enter Programming Mode again, you will start at the Timer setting, in the last saved option row (default is Option 3: 10 minutes).

Test Mode

- To test that your device is working properly, hold the TOP of the button down for 5 seconds. A RED light will blink once every 2 seconds.
- Walk around in any area to be tested. During Test Mode, every motion detected will trigger the load for 5 seconds.
- Exit Test Mode by pressing either the TOP or BOTTOM of the button. The Test Mode will also time-out after 2 minutes.

The locator LED function is disabled while in Test Mode.

Temporary Disable

- To temporarily disable the light or load from turning on, press and hold the bottom of the button for 5 seconds.
- The sensor will ignore motion keeping the light/load off. GREEN light will double flash every 2 seconds during this mode.
- Exit by pressing either the top or bottom of the button.

FCC STATEMENT: This device complies with Part 15 of the FCC Rules. Operation is subject to following two conditions: (1) this device may not cause harmful interference, and (2) this device must accept any interference received, including interference that may cause undesired operation of the device. This equipment has been tested and found to comply with the limits for a Class B Digital Device, pursuant to Part 15 of the FCC Rules. These limits are designed to provide reasonable protection against harmful interference in a residential installation. This equipment generates, uses, and can radiate radio frequency energy and, if not installed and used in accordance with the instructions, may cause harmful interference to radio communications. However, there is no guarantee that interference will not occur in a particular installation. If this equipment does cause harmful interference to radio or television reception, which can be determined by turning the equipment OFF and ON, the user is encouraged to try to correct the interference by one or more of the following measures:

- Reorient or relocate the receiving Antenna.
- Increase the separation between the equipment and the receiver.
- Connect the equipment into an outlet on a circuit different from that to which the receiver is connected.
- Consult the dealer or an experienced radio/TV technician for help.

FCC CAUTION: Any changes or modifications not expressly approved by Leviton Manufacturing Co., Inc., could void the user's authority to operate the equipment.

For Technical Assistance Call: 1-800-824-3005 (USA Only) or 1-800-405-5320 (Canada Only) www.leviton.com

When to use Occupancy or Vacancy				
Programing Mode	When to use this setting	Amount of Ambient Light Present	Turns light ON when...	Light turns OFF when...
Occupancy (DOS05 only)	When automatic ON/OFF lighting control is desired.	1. Low - Light will turn ON automatically if room is darkest. 2. Medium - Light will turn ON automatically if room has more light. 3. High - Light will turn ON automatically if room has the most light 4. Disabled - Light will turn ON always.	User walks into the view of the sensor when the light is OFF and it is darker than the ambient light level set. OR TOP or BOTTOM of button is pushed.	No motion is detected for the duration of the programmed time period. OR TOP or BOTTOM of button is pushed.
Vacancy	When Manual ON, Automatic OFF lighting control is desired.	N/A	TOP or BOTTOM of button is pushed. OR User moves around within 30 secs of the light turning OFF.	TOP or BOTTOM of button is pushed. OR No motion is detected for the duration of the programmed time period.

Occupancy/Vacancy Switch (DOS05 only)

Remove color kit and wallplate to access.

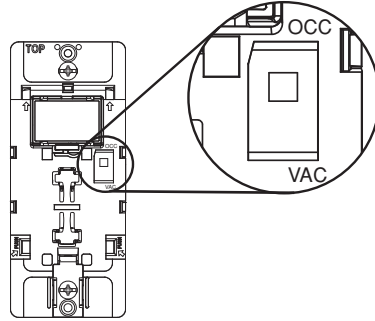

Changing your device color

Remove

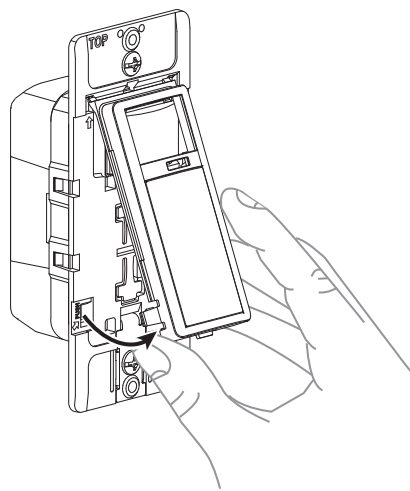

Replace

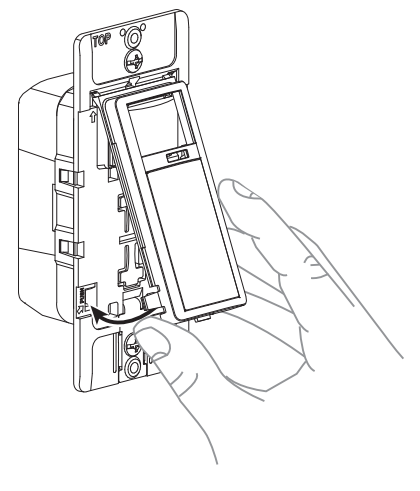

Available in White (W), Light Almond (T), Ivory (I), Brown (B), Black (E), Gray (G), (DOSKT-00x).

Sensing Area Coverage

1. Horizontal field of view:

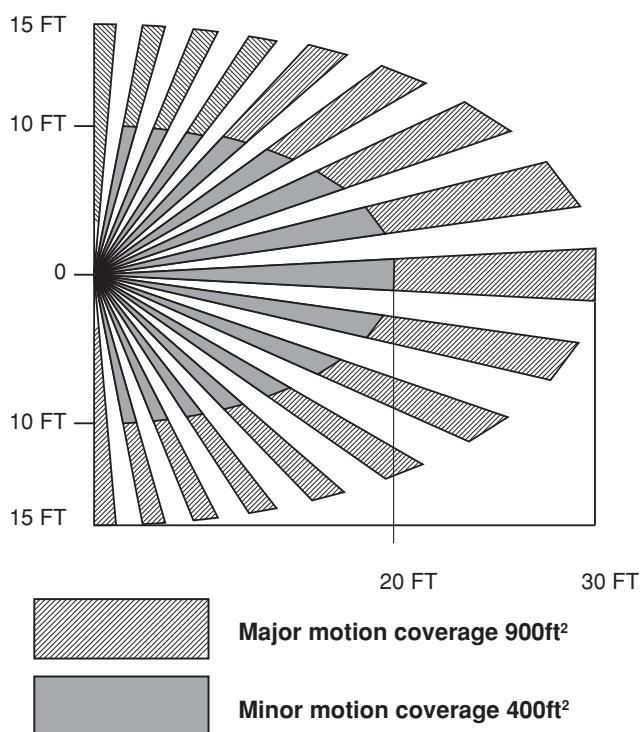

2. Vertical field of view:

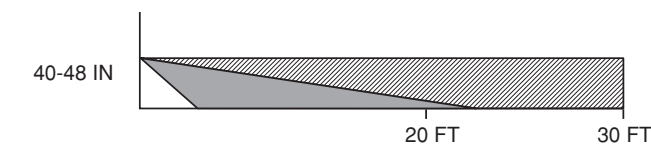

What to do if...	
Issue	Make this adjustment
Lights do not operate with push pad and RED indicator does not blink when motion is present.	<ul style="list-style-type: none"> Verify wiring connections to sensor. Make sure that control is installed correctly. Make sure the power is ON. Check to make sure the light bulb is functional.
Lights do not switch ON when motion is detected (DOS05).	<ul style="list-style-type: none"> Motion is beyond sensing range - move closer to switch. Adjust the ambient light level lower (Option 3, 2, 1 or disable). The RED light will blink to indicate motion. If it is blinking and the load is not turning ON, it could be due to ambient light. Check to make sure that the Occ-Vac switch is in OCC position.
Lights always stay ON	<ul style="list-style-type: none"> Check time delay settings and compare to how long the lights stay ON. Make sure no motion occurs in coverage area for time selected by covering the lens. Check that switch is not installed near a heat source (like stove, lights, heat vents) or detecting motion from an adjacent area (like hallway traffic) and if it is, relocate it.

Scan this code with your cell phone camera to watch a video on how to program the settings on the Leviton Decora Motion Sensor light switch.



IC STATEMENT

This device complies with Industry Canada licence-exempt RSS standard(s). Operation is subject to the following two conditions: (1) this device may not cause interference, and (2) this device must accept any interference, including interference that may cause undesired operation of the device.

Patents covering this product, if any, can be found on www.leviton.com/patents.

Leviton, the Leviton logo and Decora are the registered trademarks of Leviton Mfg. Co., Inc.

FOR CANADA ONLY

For warranty information and/or product returns, residents of Canada should contact Leviton in writing at Leviton Manufacturing of Canada ULC the attention of the Quality Assurance Department, 165 Hymus Blvd, Pointe-Claire (Quebec), Canada H9R 1E9 or by telephone at 1 800 405-5320.

LIMITED 5 YEAR WARRANTY For Leviton's limited product warranty, go to www.leviton.com. For a printed copy of the warranty, call 1-800-824-3005.