

NOTES:

1. ALL DIMENSIONS ARE IN INCHES.

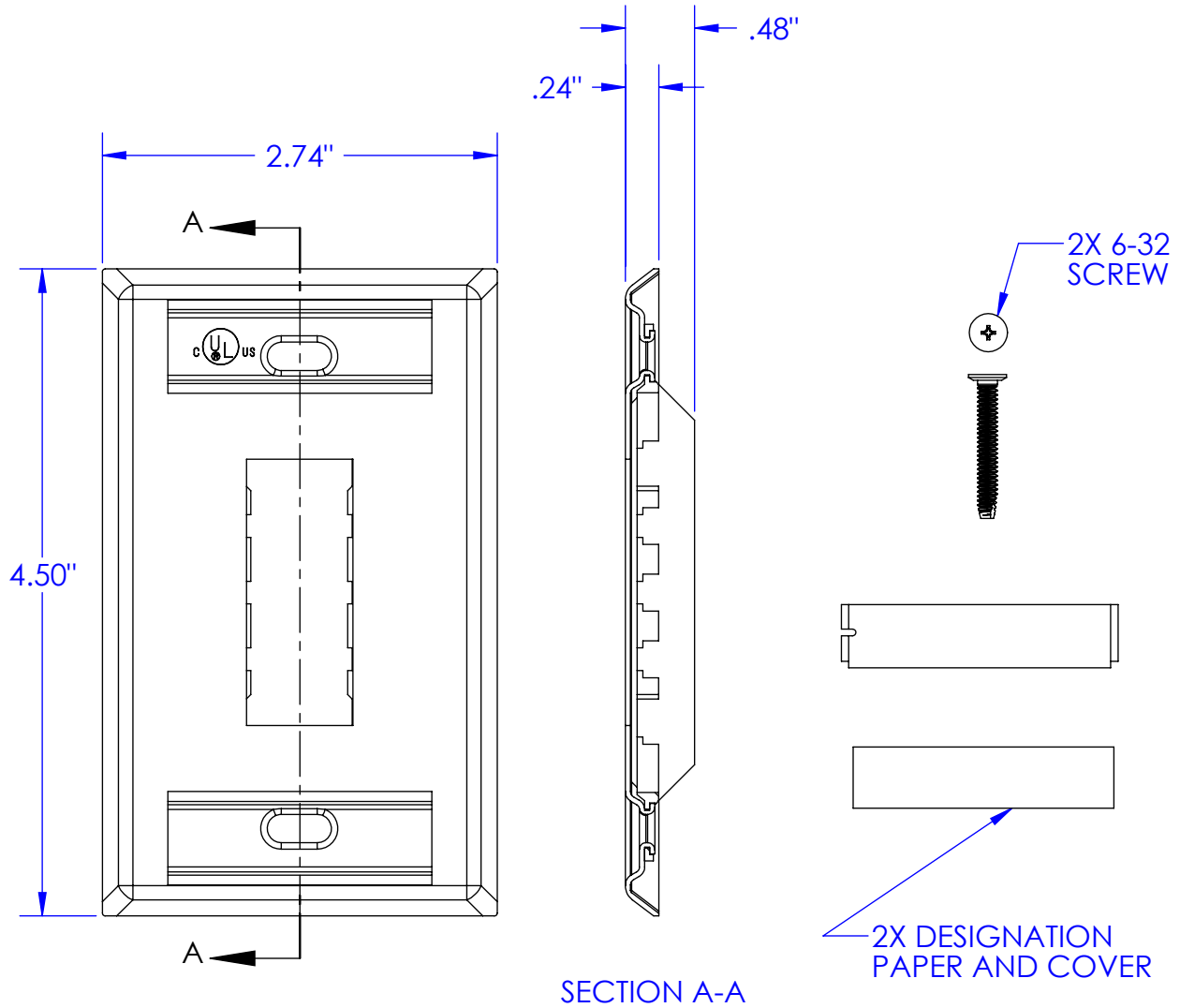

*** NOTICE ***
 THIS DOCUMENT CONTAINS CONFIDENTIAL AND/OR PROPRIETARY INFORMATION INTENDED FOR USE ONLY BY THE INDIVIDUAL(S) PROVIDED. NEITHER THIS DOCUMENT, NOR ANY INFORMATION CONTAINED HEREIN, MAY BE COPIED, DISTRIBUTED, DISCLOSED TO ANY THIRD PARTY OR USED IN ANY MANNER OTHER THAN FOR WHICH IT HAS BEEN PROVIDED, WITHOUT THE PRIOR WRITTEN CONSENT OF ORTRONICS, INC. MANUFACTURING RELEASE, PRODUCT SPECIFICATIONS AND STANDARDS ARE SUBJECT TO CHANGE WITHOUT NOTICE.



125 EUGENE O'NEILL DRIVE
 NEW LONDON, CT 06320
 TEL: 860-445-3800
 FAX: 860-405-2990
 WWW.ORTRONICS.COM

TITLE
 FP, TJ, SG, 2 HOLE, FLUSH, SS,
 LABEL FIELD, 2.75" x 4.5"

DWN	S. LEVESQUE	07/14/06	SIZE A	CAD FILE 403STJ12C	DWG NO OR-403STJ12	REV 03
CHK	COLLELO	07/14/06	SCALE NTS	SHEET 1 OF 1		
APPR	M. MARTICH	07/14/06				