

# INSTALLATION GUIDE

FX UHD

## SPLICING CASSETTE



Part Number **FC3H12LDFS** shown  
as reference only

BOM ID	Description	Qty
1	Cover	1
2	Shelf	1
3	Splice Cassette	1
4	Rubber Strip	2"
5	Cable tie	1

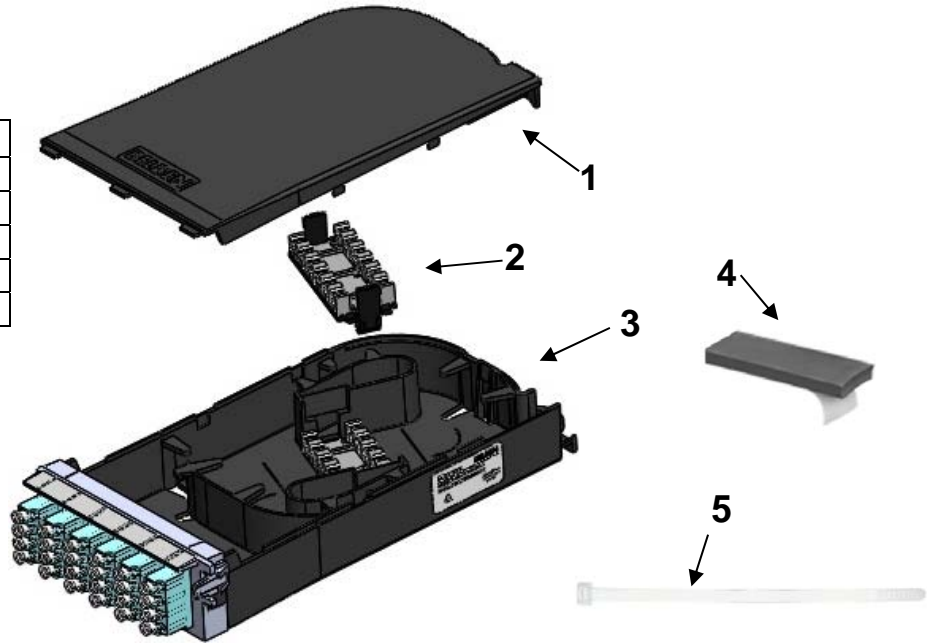

### Fiber cable and fiber pigtail preparation

Type of terminations	Dim. A	Dim. B
Single connector and Mass fusion splices	23"	26"
Brilliance connector mechanical splice	44"	N/A

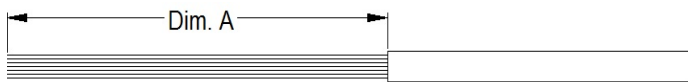

Recommended fiber's length of **distribution cable**



LC connector shown for reference only

Recommended **Pigtails** length

- Remove the cover, item 1, from cassette.
  - Remove the shelf, Item 2, from cassette.
- Cover the fiber cable with the adhesive backed rubber strip, item 4, and secure it with the cable-tie, item 5, as shown.
- When the first fusion splice is completed, route distribution cable's fiber one (1) full loop and position the protection sleeve. Refer to "Direction Arrows" of the cassette (shown in white) and **yellow** dotted arrows for fiber management.

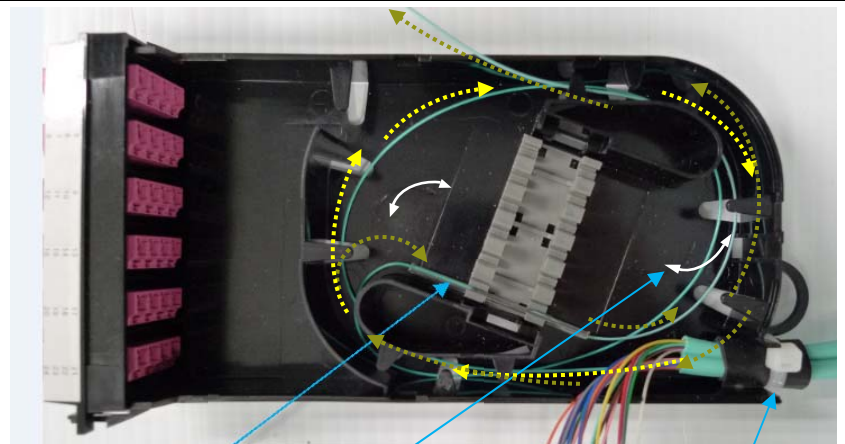

Protection Sleeve

Direction Arrow

Attach cable to cassette with the *supplied* cable-tie and the adhesive backed rubber

# INSTALLATION GUIDE

FX UHD

SPLICING CASSETTE



4. Route Pigtail one full loop and connect to appropriate port.

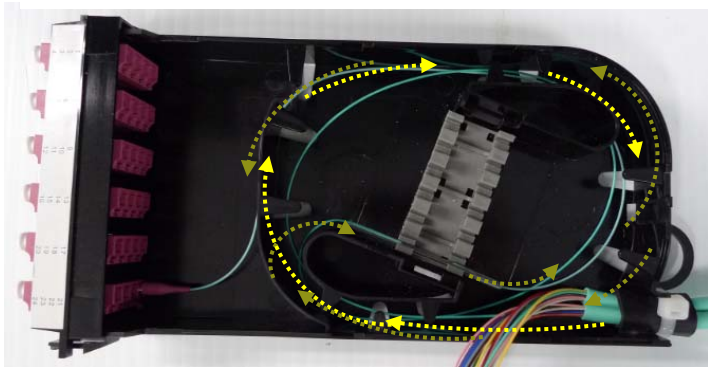

5. Repeat steps 3 and 4 until the first row of fiber is complete.

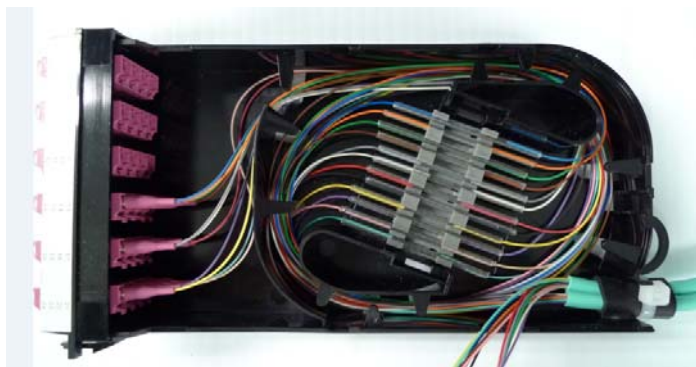

6. Once first row is complete, install shelf, item 2.

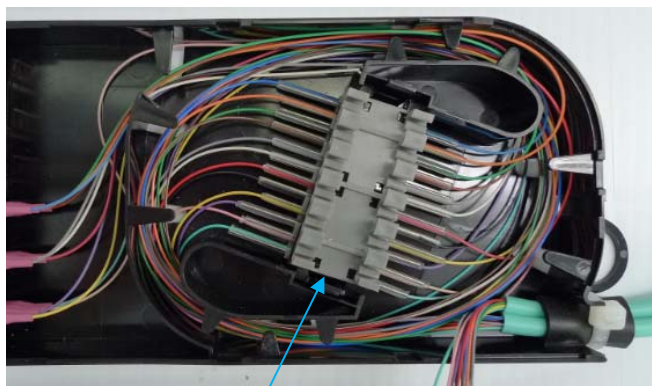

Shelf

7. Repeat steps 3, 4 & 5 until the second row of fiber is complete.

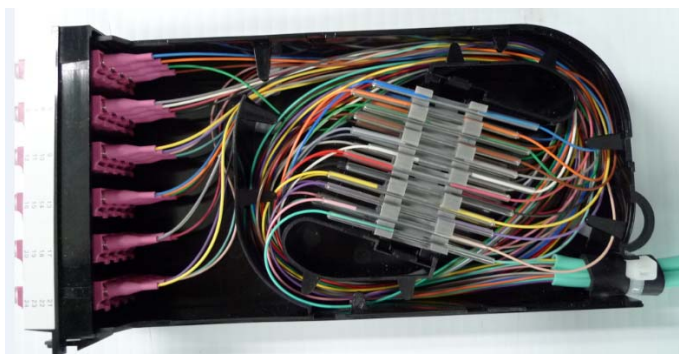

8. Install cover carefully assuring no fibers are pinched.

## Mechanical Splice or Splice-On Connectors.

When splices are completed route fiber (2) full loops and as shown at steps 6, 7 and 8.

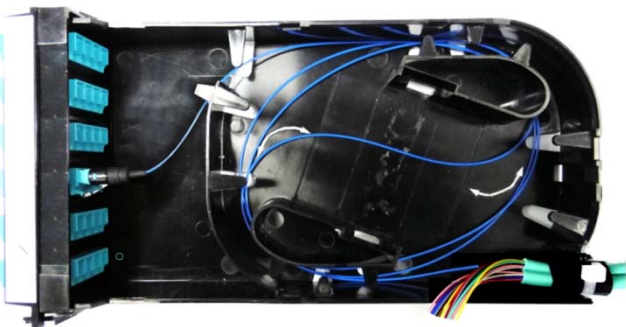

Picture 1

## Mass fusion splice (LC connectors shown)

Route fibers and cables as shown at steps 3, 4, 5 and 8.

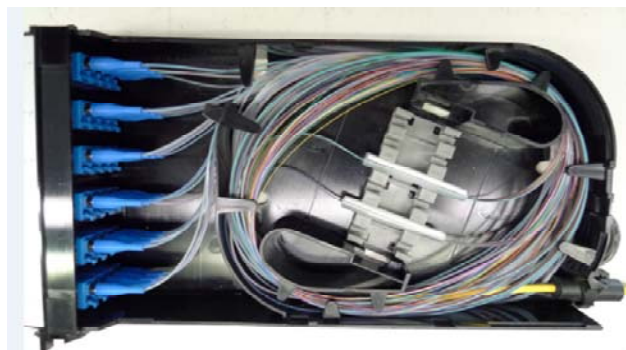

Picture 2