



ORTRONICS

125 EUGENE O'NEILL DRIVE
 NEW LONDON, CT 06320
 TEL: 860-445-3800
 FAX: 860-405-2990

TITLE

TechChoice
 24 AND 48 PORT
 ANGLED PATCH PANEL

PORTS	JACK	DENSITY	WIRING	SIZE (A)	PART # (CAT6)	PART # (CAT5e)
24 PORT	8 POS/RJ45	HD	T568 B or A	1.75 X 19	SPA6U24	SPA5EU24
48 PORT	8 POS/RJ45	HD	T568 B or A	3.50 X 19	SPA6U48	SPA5EU48

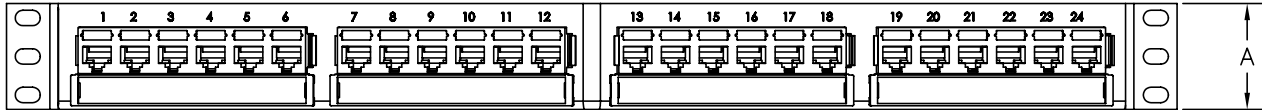

FRONT VIEW ANGLED 24 PORT

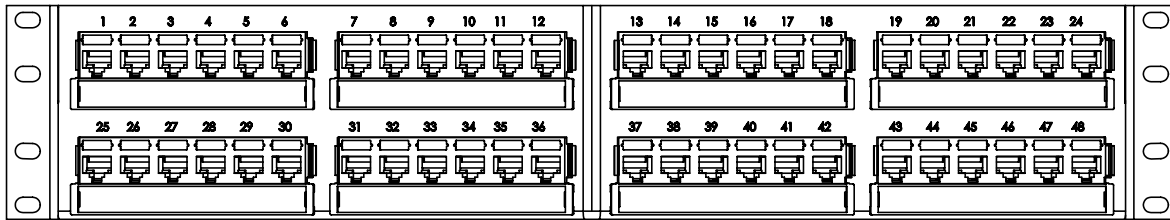

FRONT VIEW ANGLED 48 PORT

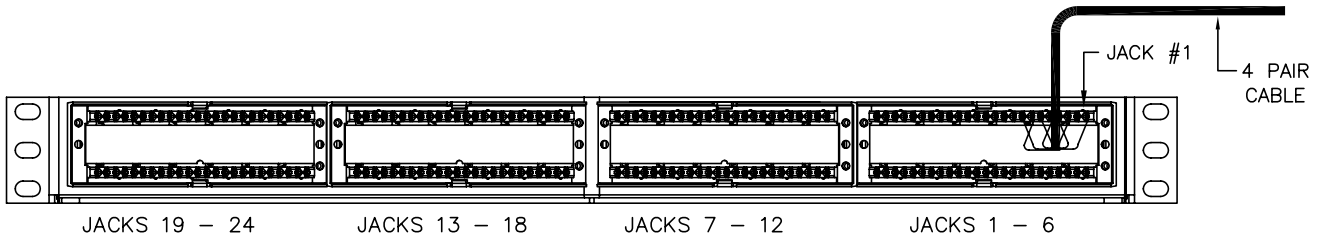

REAR VIEW ANGLED 24 PORT

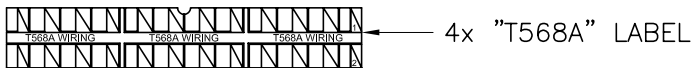

STATION CABLE COLOR CODE	T568A WIRING	STATION CABLE COLOR CODE	T568B WIRING
WHITE/BLUE	5	WHITE/BLUE	5
BLUE/WHITE	4	BLUE/WHITE	4
WHITE/ORANGE	3	WHITE/ORANGE	1
ORANGE/WHITE	6	ORANGE/WHITE	2
WHITE/GREEN	1	WHITE/GREEN	3
GREEN/WHITE	2	GREEN/WHITE	6
WHITE/BROWN	7	WHITE/BROWN	7
BROWN/WHITE	8	BROWN/WHITE	8

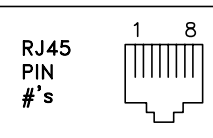

- NOTES:
- PANEL IS SUPPLIED WITH T568B LABEL IN PLACE. FOR T568A WIRING, ATTACH FOUR SUPPLIED T568A WIRING LABELS.
 - MAINTAIN PAIR TWIST UP TO POINT OF TERMINATION FOR MAXIMUM DATA PERFORMANCE.

SUGGESTED ACCESSORY TOOL

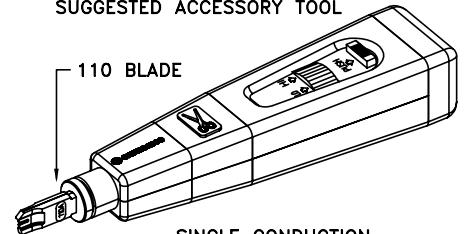

SINGLE CONDUCTION
 110 IMPACT TOOL FOR
 TERMINATION OF CONDUCTORS
 OR-60300005 (TOOL)
 OR-60300006 (BLADE)



ORTRONICS

125 EUGENE O'NEILL DRIVE
NEW LONDON, CT 06320
TEL: 860-445-3800
FAX: 860-405-2990

TITLE

TechChoice 24 AND 48 PORT ANGLED PATCH PANEL

NOTE: IF GROUNDING IS REQUIRED BY LOCAL CODE, USE STAR LOCKWASHER, AS SHOWN.

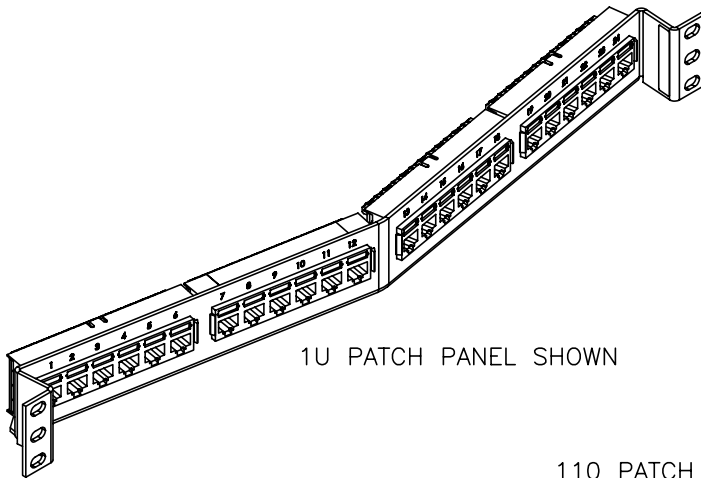
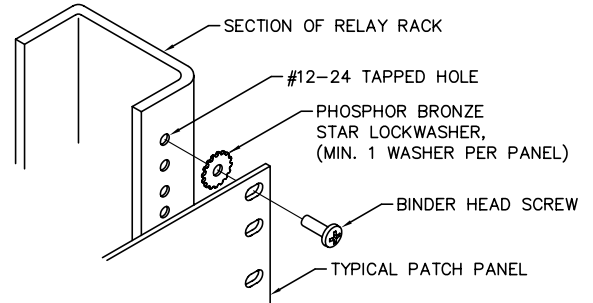

1U PATCH PANEL SHOWN

110 PATCH PANEL INSTRUCTIONS:

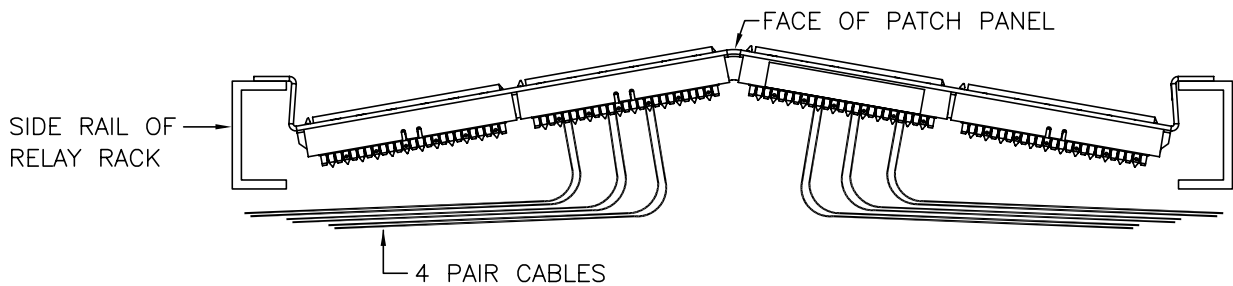

TOP VIEW (SIMPLIFIED)

For optimum cable management, the cables should be Routed and Terminated working from the center of the patch panel to the outside edges.

Note: The cables should be routed from both sides of the Relay Rack rather than from one side only.

Maintain pair twist to within 1/2" (13mm) of point of termination for maximum data performance.

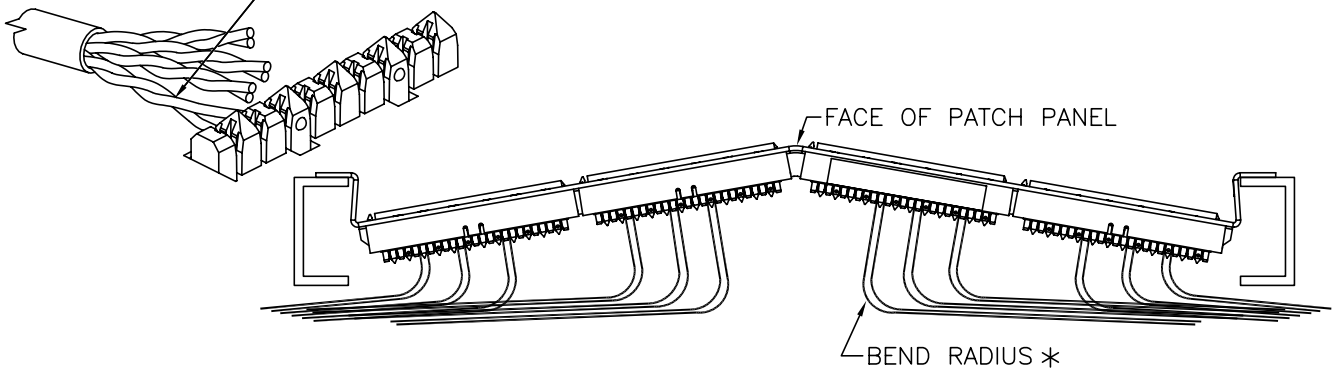

*The Minimum Cable Bend Radius is 4 times the outside Cable Diameter.

INSTRUCTION SHEET NO.	REV	ECN	SHEET	DWN.BY:	DATE	CK. BY	DATE	APP.BY:	DATE
OR-71601716	00		2 OF 2	RYNASKI	11/17/09	C.COLLELO	11/18/09	W.DIETZ	11/18/09