

ECX - 1U/2U

QUICK START GUIDE

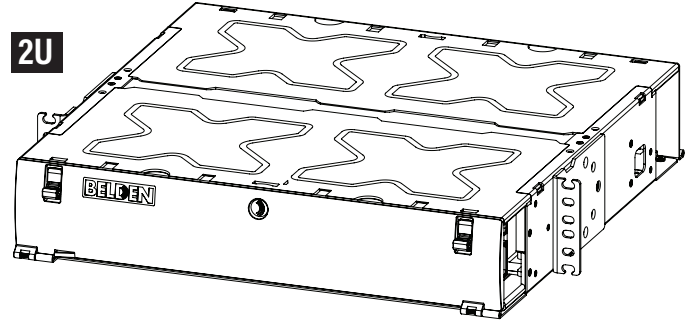

ES: Visite nuestra pagina web www.belden.com para obtener el guía de instalación en español.
 FR: Veuillez visiter notre site web au www.belden.com pour obtenir le guide d'installation en français.

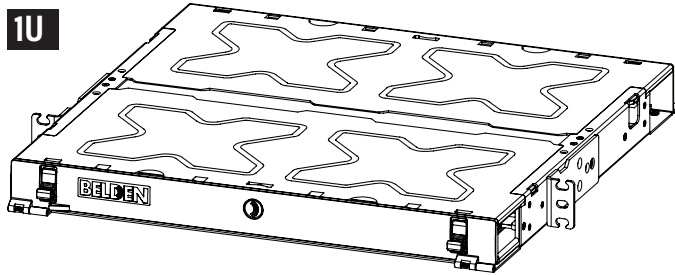

Carton contents

1. Rear door
2. Housing
3. Front door
4. Sliding tray assembly
5. Patch cord Management clip (3x)
6. Removable cover (2x)
7. Label cards (2x)
8. Installation guide & labels (not shown)
9. Hardware kit

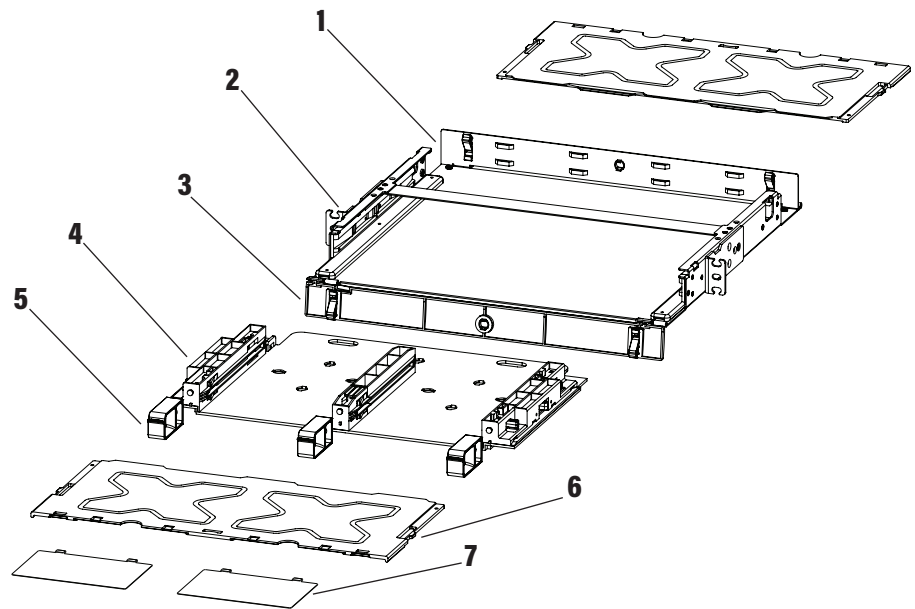

Hardware kit contains:

(Not all parts are shown)

- Blank frame (2x)
- I.D label (3/6/12) ports (2x)
- I.D label (8/16) ports (2x)
- Management clips (8x)
- External strain relief - right (1x)
- External strain relief - left (1x)
- Intermediate strain relief (1x)
- Internal strain relief assembly (1x)
- #6-19 x 1/4", screw for plastic (4x)
- #6-19 x 1/2", screw for plastic (2x)
- #12-24, machine screws Phillips (4x)
- #10-32, machine screw Phillips (2x)
- M4 x 5mm, Metric screw (4x)
- Cable tie - 4" (4x)
- Cable tie - 7 1/2" (4x)
- Velcro 8" (4x)

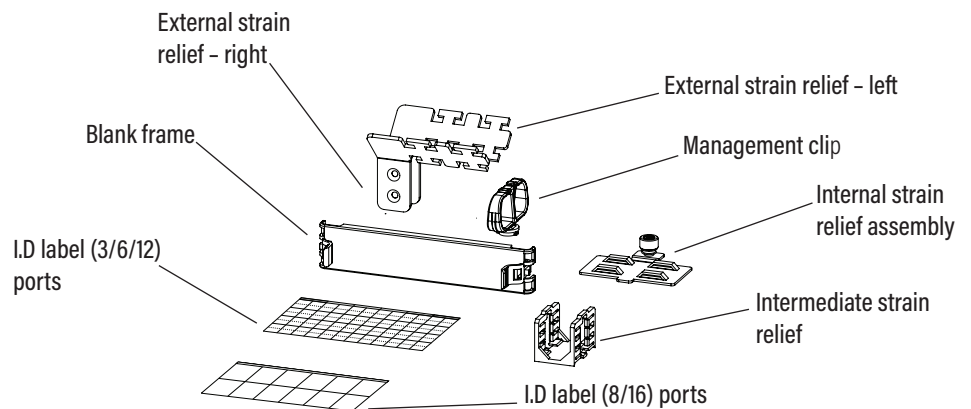

NOTE: The items listed are for 1U contents only.

Mounting the ECX housing

- 1 Insert the bottom screws into the rack or cabinet as shown (use #12-24 or #10-32 machine screws provided in the hardware kit). Leave $\frac{1}{4}$ " of the screw exposed.
- 2 Install the housing into the rack and position the bottom slots of the mounting bracket onto the installed screws. These screws will carry the weight of the housing during the installation.
- 3 Thighten the installed screws firmly. Insert and tighten top screws.

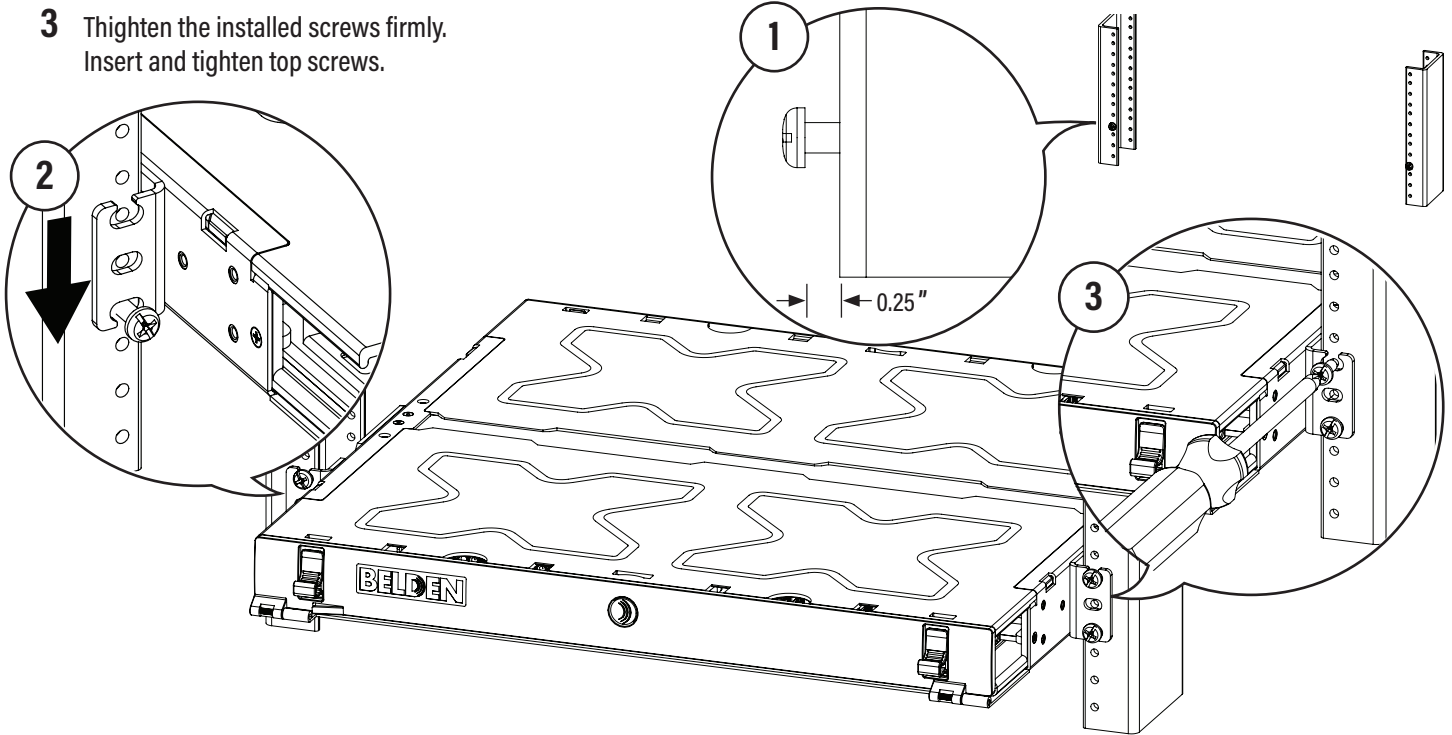

Removing the cover

- 1 Open the front or rear door.
- 2 Remove the front or rear cover by pressing the side latches simultaneously.

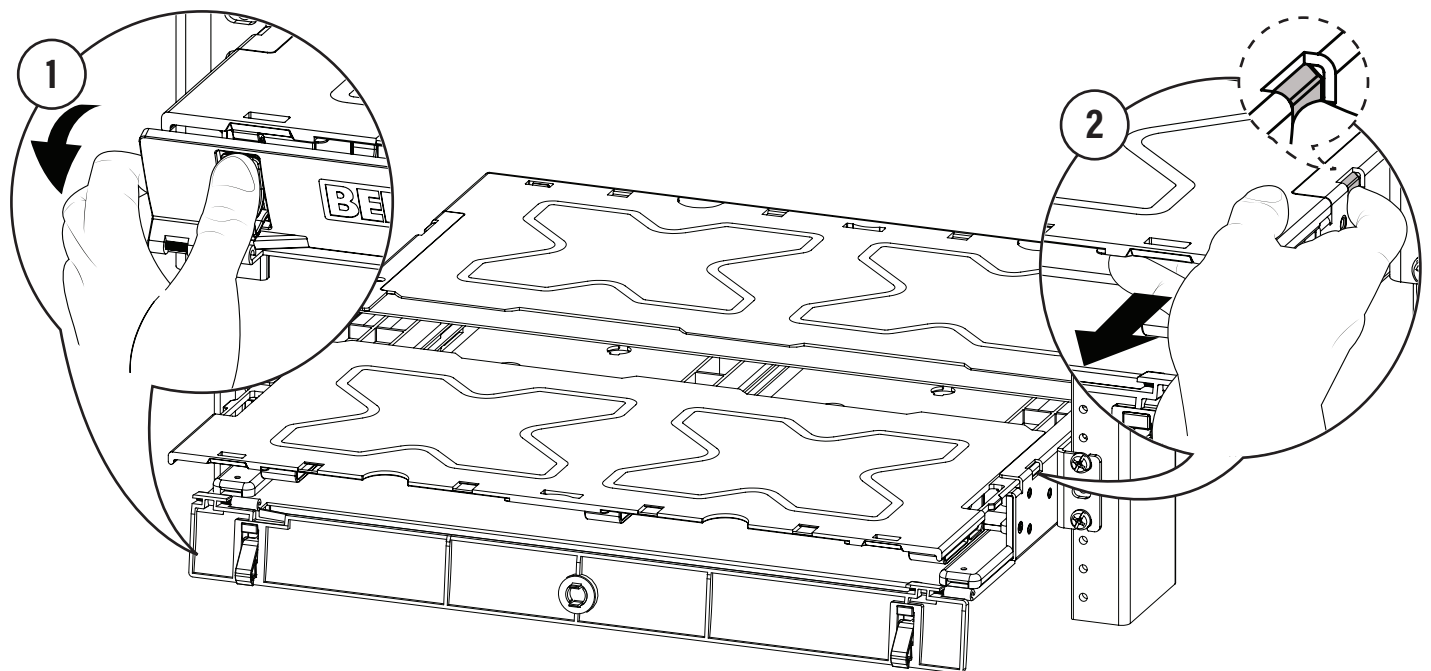

Removing the tray

- 1** Pull the tray from both sides simultaneously with enough force to disengage from neutral position as shown. Slide the tray forward until stopping point.
- 2** Squeeze latches on both sides simultaneously to release the tray as shown.

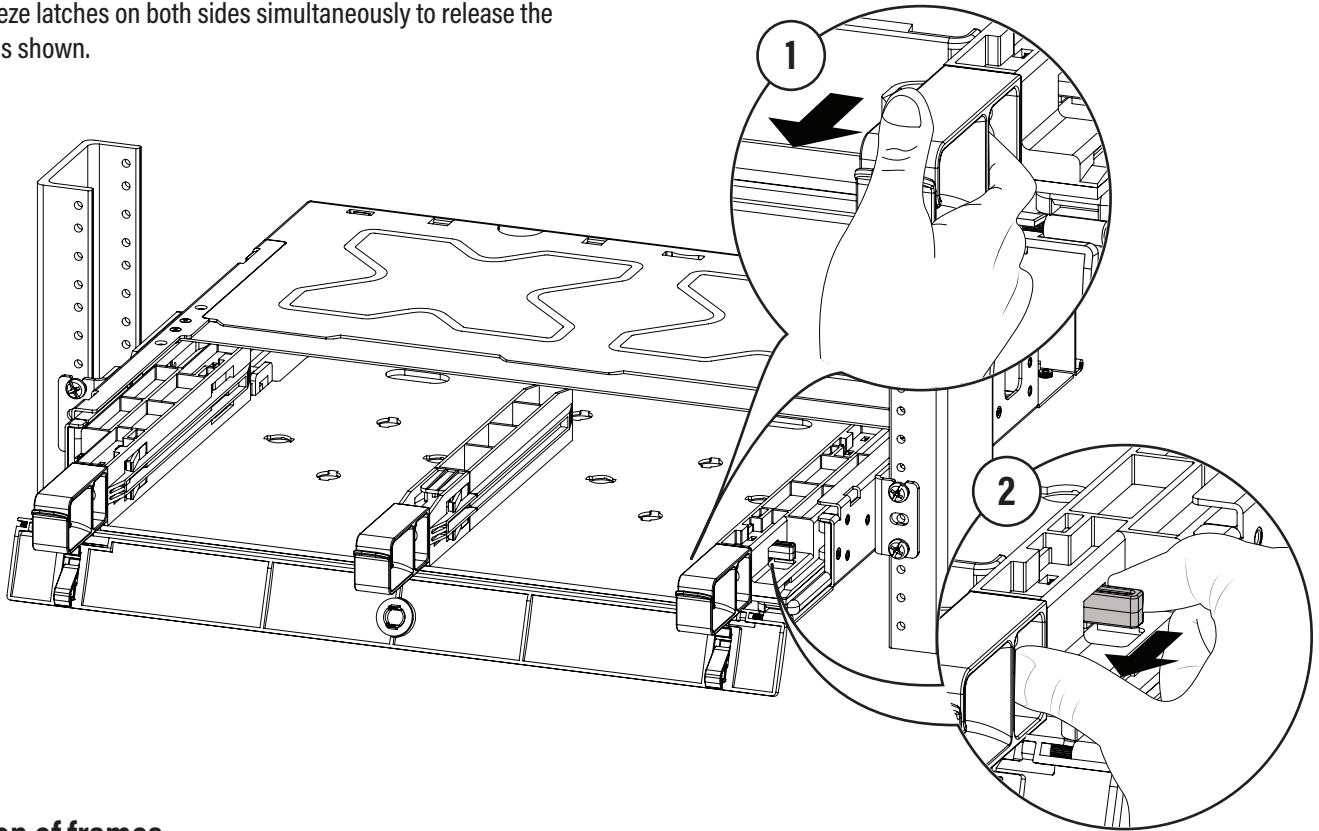

Installation of frames

- 1** Install the desired frame as shown.
- 2** Remove the installed frame by pressing both tabs simultaneously.

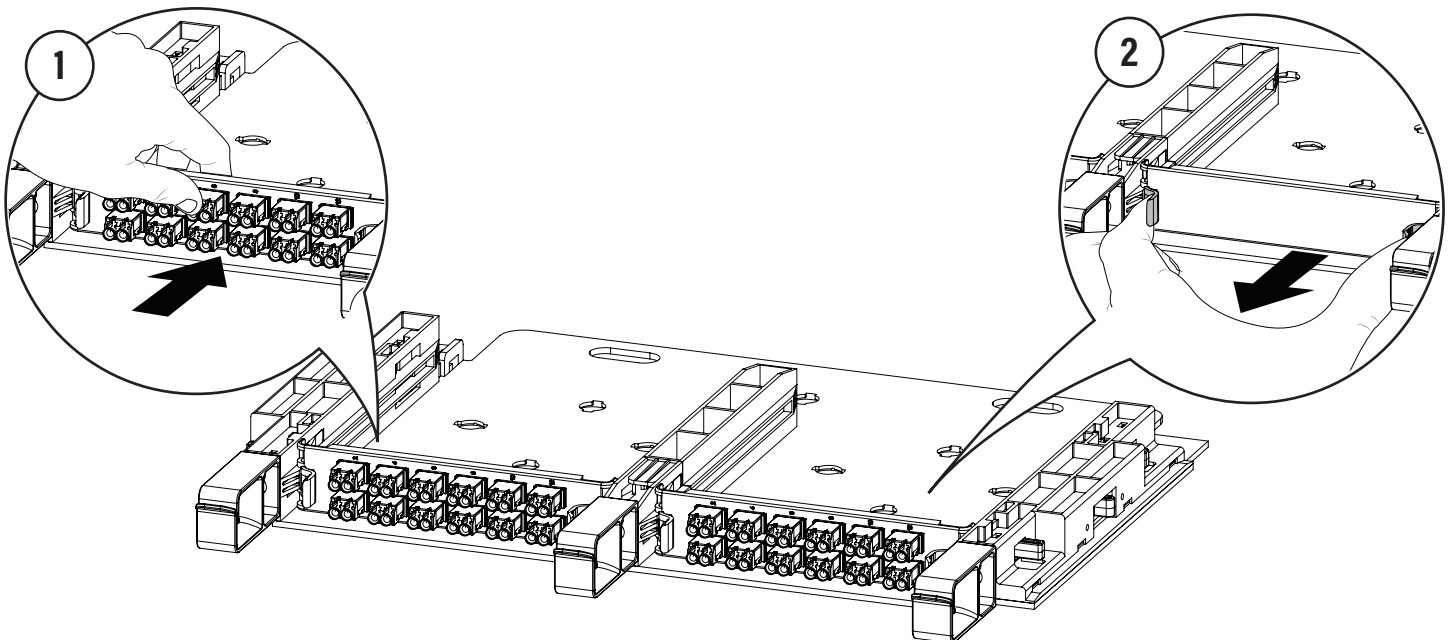

Installing distribution cable for field termination

IMPORTANT: Please take note that this is the recommended procedure.

- 1 Prepare the cable using the following dimensions: leave 25" (0,64 m) of sub-unit and 84" (2,13 m) of 900 micron fiber.
- 2 Remove the cassette guide by pulling the latch upwards and sliding it backwards.
- 3 Install the intermediate strain relief and the management clips by pushing and rotating them 90 degrees.
- 4 Secure the end of the sub-unit cables to the intermediate strain relief by using the provided small cable ties.
- 5 Loop and secure the distribution cable to the internal strain-relief.

! CAUTION: Do not over-tighten the cable ties.

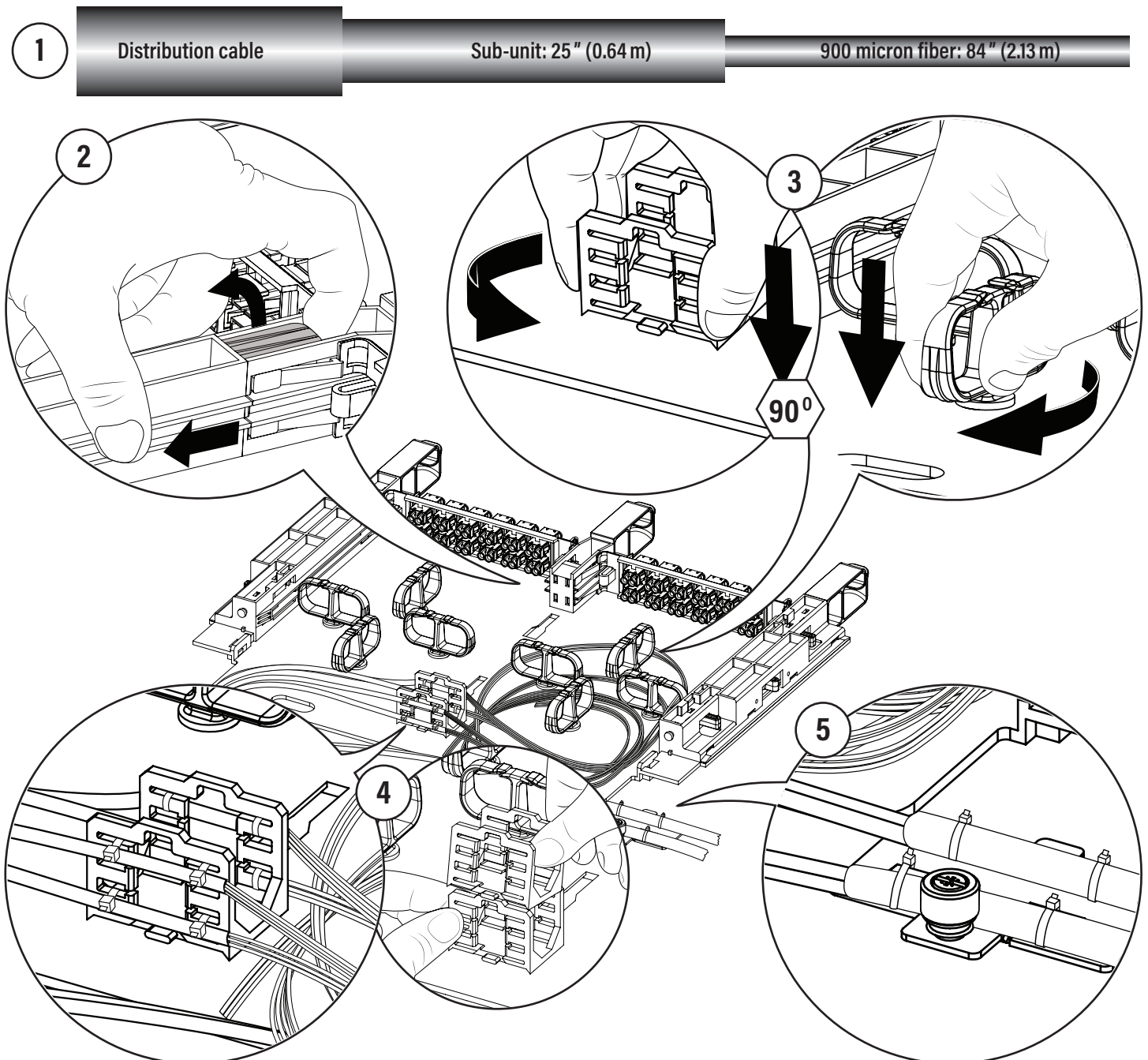

Installing distribution cable for field termination (continued)

- 6 Route the 900 micron fiber by using the management clips.
- 7 Install connectors in the desired frame.

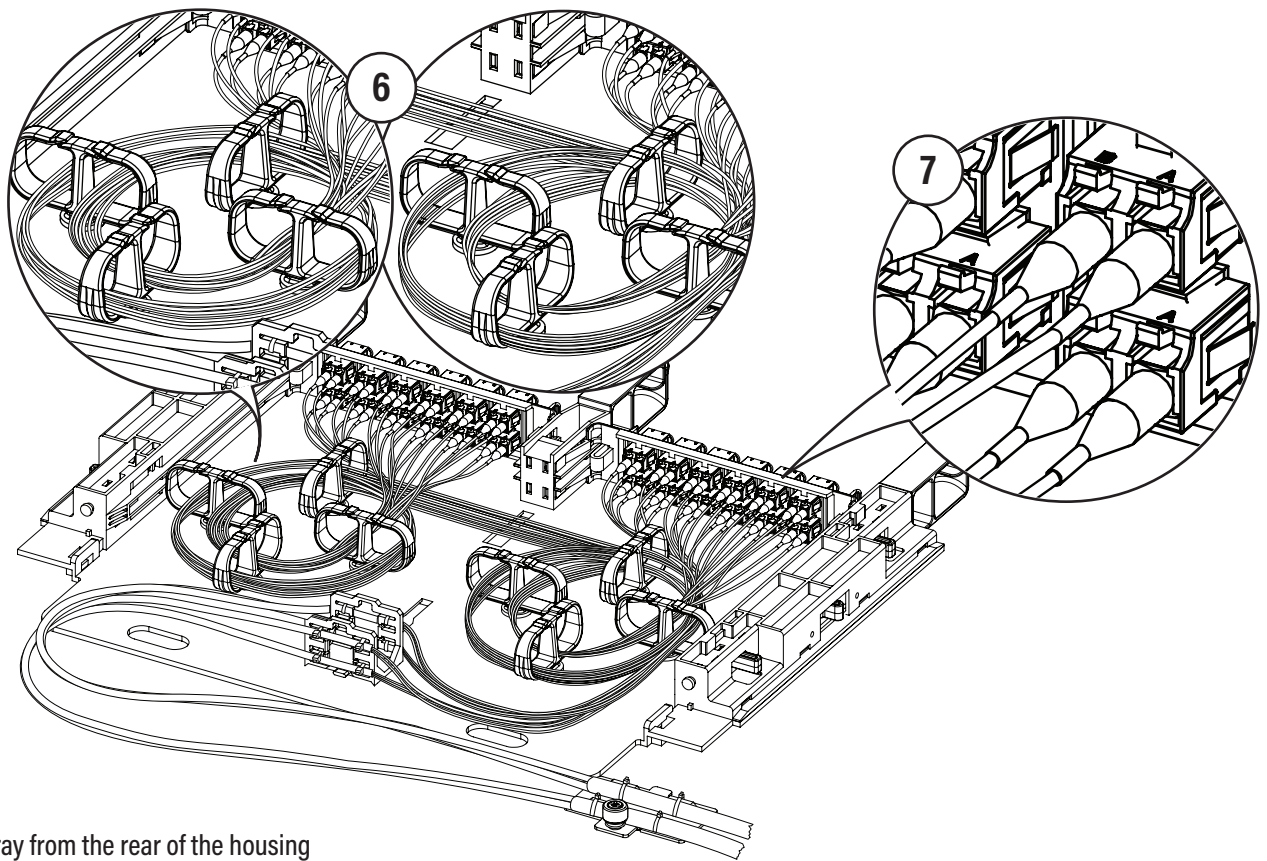

- 8 Slide the tray from the rear of the housing
- 9 Slide the tab of the internal strain relief as shown. Tighten the screw to secure it. Reinstall the cover (if removed).

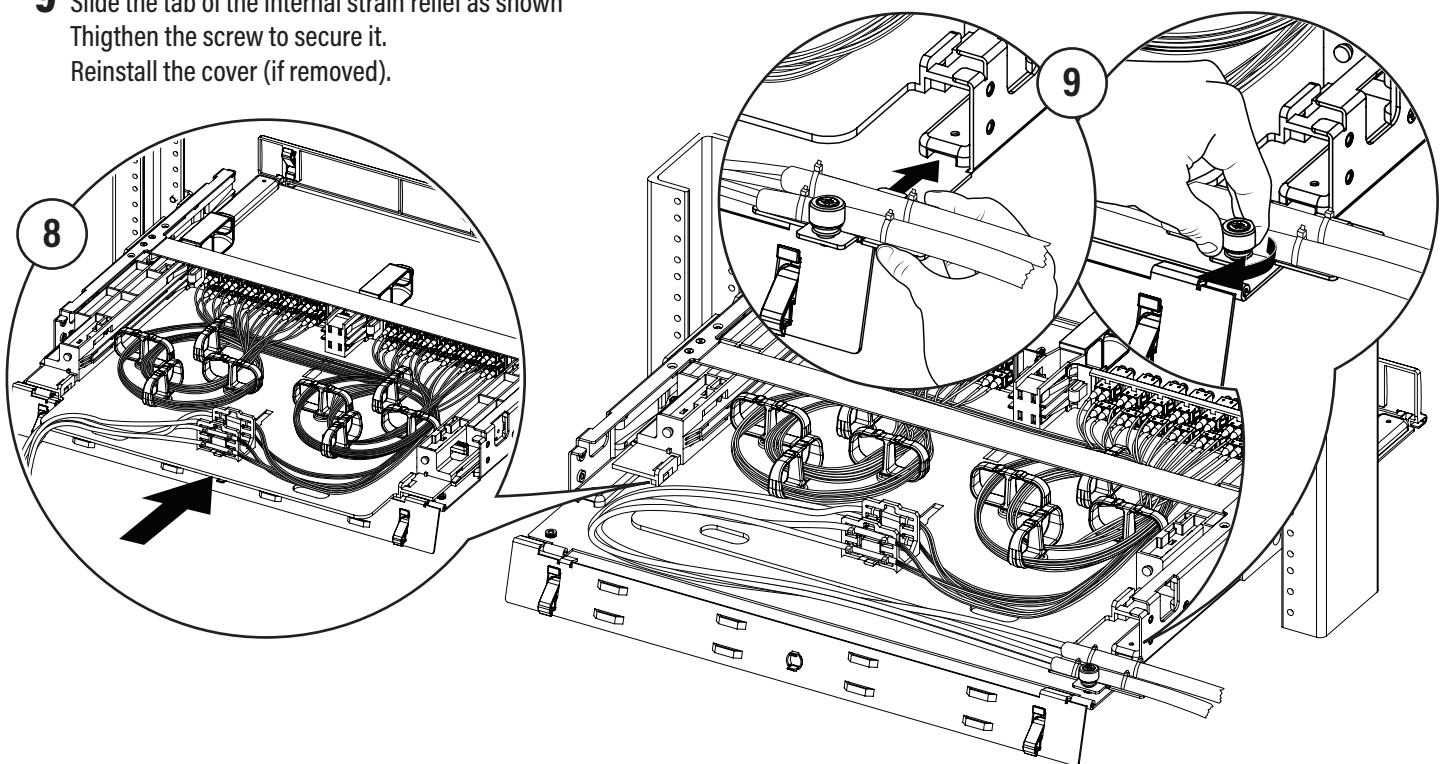

Installing distribution cable for ECX splice cassette installation

IMPORTANT: Please take note that this is the recommended procedure for the cassette installation. This installation guide does not include how to route the fiber inside the cassette. For further information on the cassette routing, please read the cassette installation guide or visit our website at www.belden.com.

- 1** Measure 17.5" (0,45 m) of sub-unit cable from the end of the cassette.
- 2** Slide the cassette in the tray until the latch is clipped.
Remove the cassette (if needed) by pressing on the rear or front tabs simultaneously.
- 3** Install the external strain-relief to the rear housing by using the provided screws.
NOTE: External strain reliefs can be installed to the right or left side.
- 4** Attach the distribution cable with the provided cable tie.
Reinstall the cover (if removed).

⚠ CAUTION: To prevent cable internal damages, close the housing rear door slowly and (if needed) move the sub-unit to prevent any pinching between the slot of the door and the cable. Do not over-tighten the cable tie.

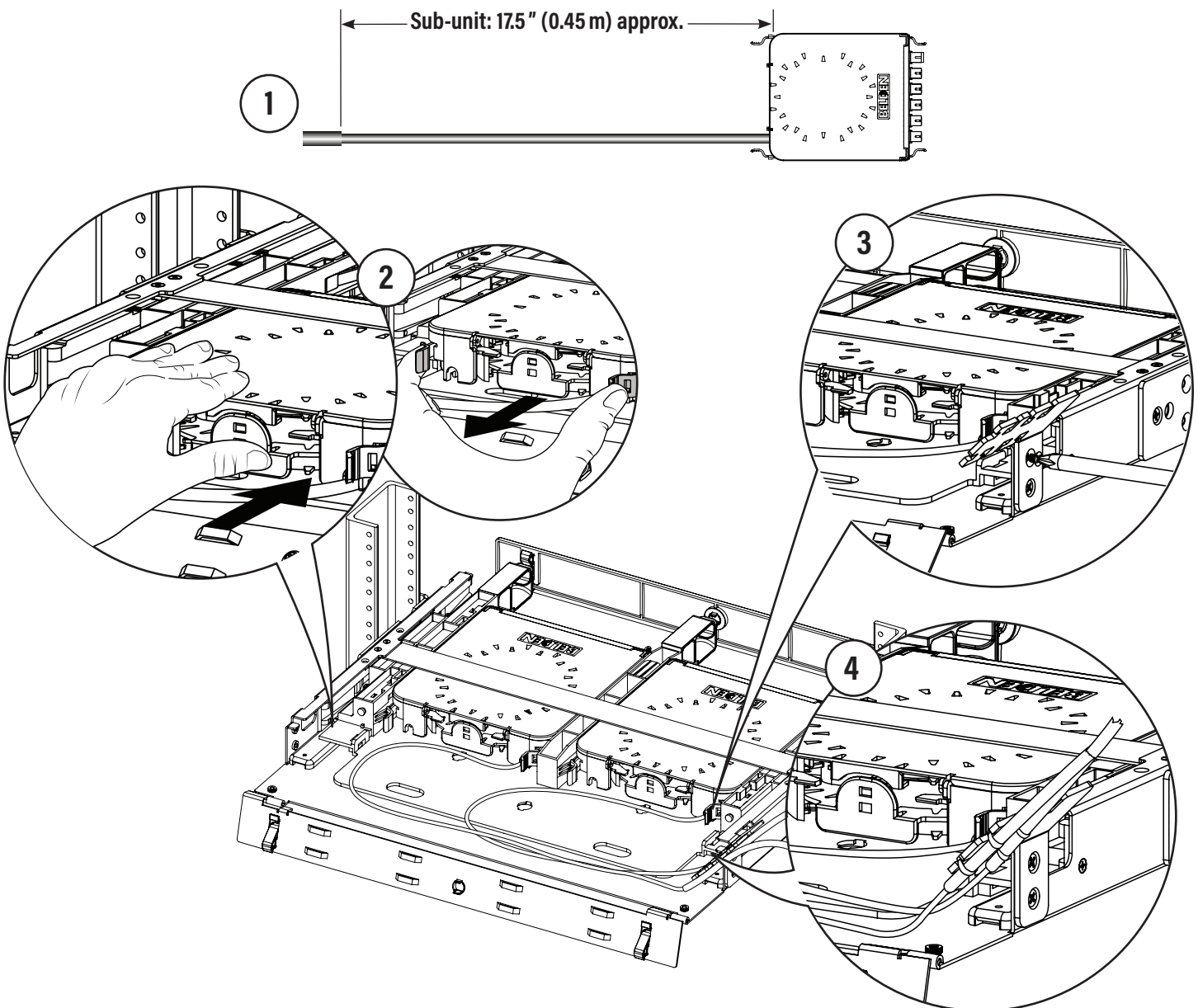

ECX labelling

- 1** Pull out the label card.
- 2** Tilt the label card upwards.
- 3** Remove the label card by pushing downwards.
- 4** Apply the provided adhesive label to label card.
NOTE: Surface should be cleaned properly before applying label.
- 5** Reinstall the label card.

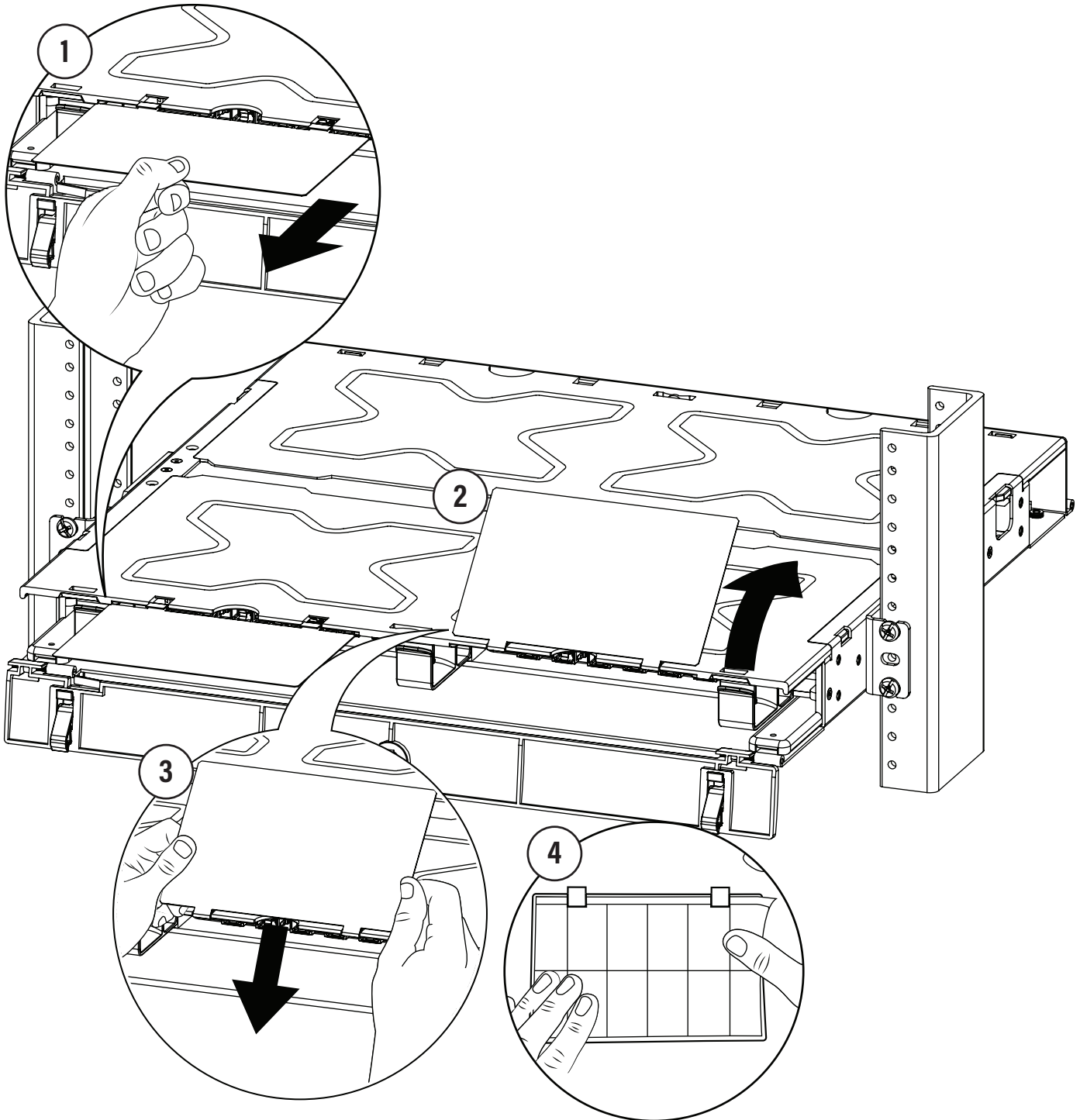

Proposed patch cord management

NOTE: The tray is pulled forward to facilitate visibility.

