

# Honeywell

## FSL100 Series Flame Detector Quick Start Guide

### Standalone wiring

Terminal 1 has a blocking diode for reverse polarity protection and a multi-fuse for overcurrent protection

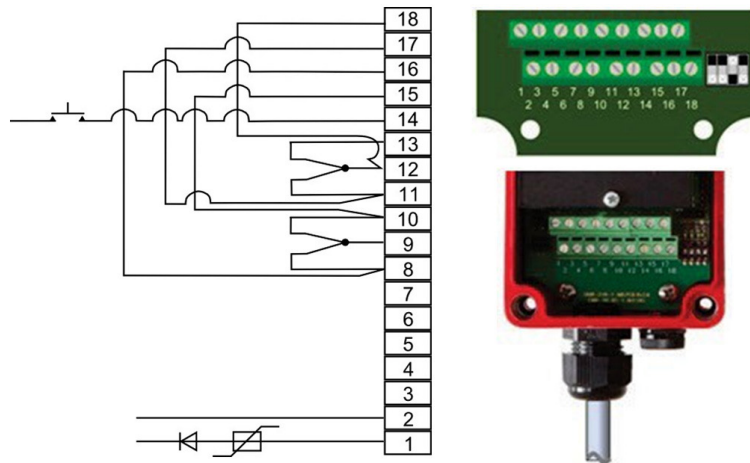

Figure 1. Wiring diagram (power on - normal)

Terminal	Input	Terminal	Input
1	+10 to +28 VDC Input	10	NC Alarm
2	-Ve Input	11	NC Fault
3	Not in use	12	MC Fault
4	Not in use	13	NO Fault
5	Not in use	14	+10 to +28 VDC Manual Self Test Input (>5 s)
6	Not in use	15	EOL Resistor
7	4-20 mA Sink Output	16	AL Resistor
8	NO Alarm	17	EOL Resistor
9	MC Alarm	18	AL Resistor

### Standalone wiring with direct use of relays

- Use multi-core, shielded, twisted pair cable with earth (ground), depending on the panel and the type of connection. The isolation resistance to ground must be at least 500K ohm.
- Core size must be 0.5 to 1.5 mm<sup>2</sup> (20-16 AWG).
- Select the length and diameter of the wires so that the flame detector will have sufficient power under all conditions (normal and alarm) so that the operating voltage is never below 10 VDC, especially when in alarm mode.
- On the flame detector side of the cable, leave a 4 in. (10 cm) loop of spare cable to allow for alignment of the detector.
- Grounding on the flame detector side: ensure that the screen cannot make an electrical connection with ground or with the electronics in the detector housing. To avoid potential differences (ground loops), ensure that the electronics in the flame detector housing are isolated from local ground.
- Do not connect more than one detector per loop.

The flame detector has a cable gland fitted with an 8 mm insert. Use the cable gland with the insert for cables from 5.5 – 8 mm diameter. Remove the insert for cables of 8 – 13 mm diameter.

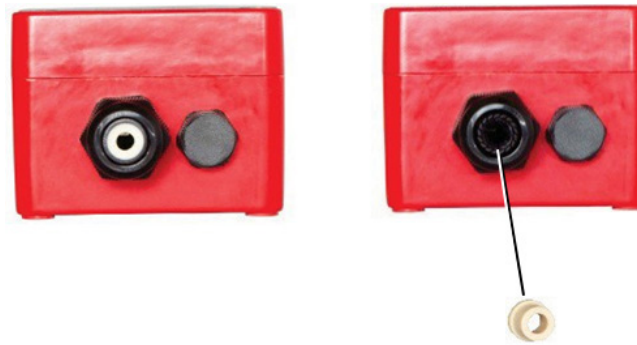

Figure 2. Cable gland with and without the cable entry insert

### Wiring to a control panel

The flame detector can be connected to a fire control panel using the current increase principle. The flame detector is connected to the fire panel with three or four core cables, i.e., two cores for the power supply and one or two cores for the loop. An additional core for the manual self-test can be used.

The end of line resistor (EOL) is placed between the terminals 15 and 17. The alarm resistor (AL) is placed between terminals 16 and 18. The end of line and alarm resistors should be adapted to the fire control panel. They are approximately the same size resistors that are used when connecting a manual call point to a fire control panel.

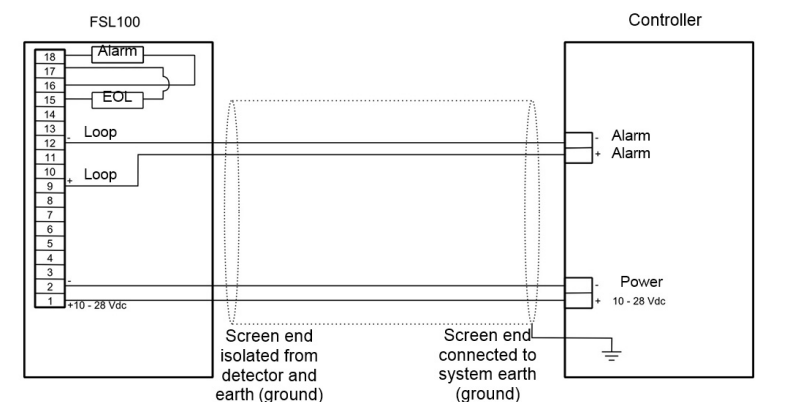
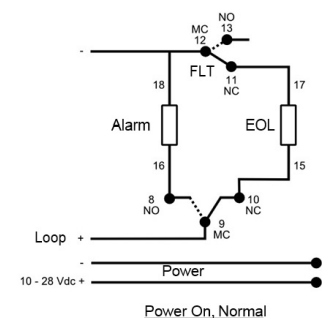

Figure 3. Control panel wiring



### Wiring to a 4-20 mA current sourcing PLC

An FSL100 detector current sink can be wired to a 4-20 mA non-isolated (sourcing) output of a controller as shown in Figure 4.

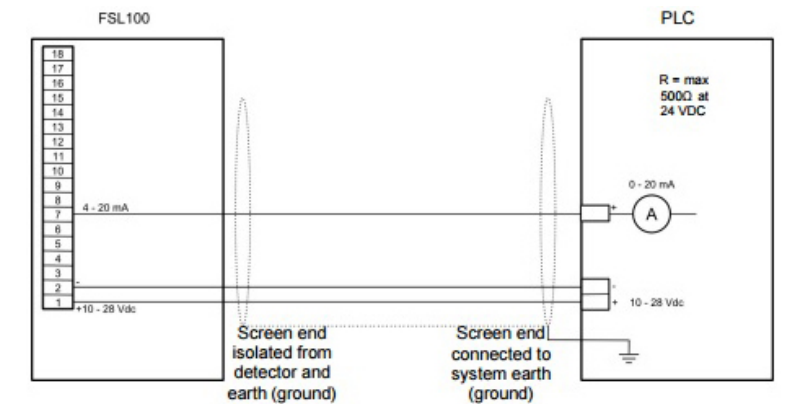

Figure 4. Wiring a current source PLC

The 4-20 mA sinking input has the following values:

- $\geq 4$  mA = Normal operation
- $\geq 20$  mA = Alarm
- 2 mA = Optical fault
- 0 mA = Fault

### Wiring to a 0-20 mA controller with sinking input

An FLS 100 detector can be wired to a controller with 0-20 mA non-isolated (sinking) input by using the controller's alarm and fault relays, as shown in Figure 5.

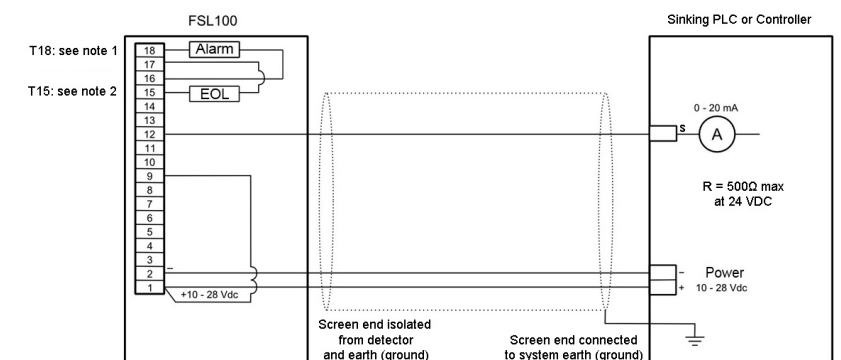

Figure 5. Wiring to a PLC or controller with a 4-20 mA sinking input

Values of the detector's 0-20 mA output:

- 4 mA = Normal operation
- 20 mA = Alarm
- 0 mA = Fault; the 0 mA current will change to 20 mA (alarm) if flames are detected while the source is in fault

Note that in this configuration two wires are connected to terminal #1. This is forbidden in some jurisdictions so verify that it is in compliance with local regulations.

- For a PLC the value of the ALARM resistor =  $V_{nominal}/20$  mA, for controllers refer to the brand related resistor table.
- For a PLC the value of the EOL resistor =  $V_{nominal}/4$  mA, for controllers refer to the brand related resistor table.

## The Display LEDs

The detector has three display LEDs:

- Steady green: powered up and in normal operation
- Steady yellow: fault
- Blinking yellow: repeated self-test after a self-test fault
- Steady red: alarm

## Normal Operation

The green LED is on when power is applied and the detector is in normal operation. That LED turns off and the red alarm LED turns on whenever the detector senses an alarm condition. Under default settings, the alarm will remain latched (held on) until the event is cleared and either the alarm is reset at the controller or the detector's power is cycled.

Alternatively, if the latch setting has been changed to unlatched, the detector will return to normal operation once the alarm trigger event has been removed. Note that the optional alarm system relay outputs may be triggered during an alarm condition.

## Fault Conditions

The yellow and green LEDs are illuminated when a fault condition occurs. The yellow LED turns off as soon as the fault is cleared.

The green and yellow LEDs turn off and the red LED turns on if an alarm occurs during a non-critical fault condition (i.e., during an IR or UV lamp test).

A blinking yellow LED shows that a self-test is in progress. The LED will become steady yellow if the detector repeatedly fails the self-test.

## Relay Outputs

The flame detector has two relay outputs:

- Alarm relay (SPDT) that can be used to operate an alarm or relay-controlled event. It can be changed from latching (the default) to unlatched. A latched alarm can be reset by the controller or by cycling the detector power off and on.
- Fault relay (SPDT). The fault relay is energized when the detector is powered up and will be de-energized in the event of a fault. The fault relay is non-latching.

## Latching/Non-latching Alarms

The detector uses DIP switch 3 for field-selectable alarm latching or unlatching as shown in Figure 6. The default setting is latching.

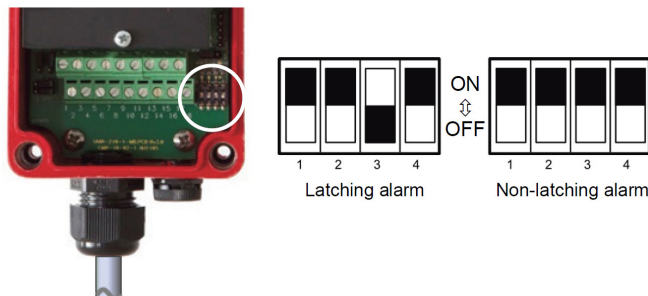

Figure 6. Latching alarm settings

To change the alarm's latching status, change the DIP switch, power off for at least a second, and then power on again.

## Analog Output

The analog output (0-20mA, stepped, sinking, non-isolated) has these possible values:

- 0 mA power fault / microprocessor fault
- 2 mA optical fault
- 4 mA normal operation
- 20 mA alarm

If the detector senses a fire during a fault, the output defaults to 20 mA.

## Self-Testing

During power up, the detector performs a power on self-test (POST) and the LEDs flash sequentially until it is completed (about 10 seconds). The LED sequence is replaced by a steady green LED if the detector passes the test.

While powered up, an optical self-test is periodically and automatically executed to monitor the electronics and the sensor(s). During this short test the yellow LED may flash and the detector's outputs will be temporarily inhibited. The test may repeat several times if a sensor fails the optical self-test.

The yellow fault LED will be steady and the fault relay will de-energize if the fault condition remains after repeated self-tests.

## Manual Self-Test

The flame detector can test the sensors as well as the signal processing with help from the optional manual self-test circuit.

During a successful manual self-test, the alarm relay is energized and the red alarm LED glows. If the detector is latched, the alarm continues until the detector is powered off.

For the manual self-test, a switch can be mounted in the controller or connected externally to a +10 to +28 VDC supply. (See "Connecting the Manual Self-Test" in the *FSL100 Technical Handbook*.)

During commissioning, this option can be tested by shorting the detector's terminals 1 and 14 for no more than 5 seconds.

## CAUTION

Inhibit or isolate relay-operated outputs and alarms before performing any work on an alarm system. Verify that the alarm system has been returned to normal operation when the work is completed.

The manual self-test can be used during commissioning to test the detector without using a test lamp. The manual self-test is not a replacement for the functional test using a test lamp. After commissioning, the detector must be functionally tested with a test lamp.

## Maintenance

The user is responsible for keeping the equipment in optimal condition. Contact Honeywell Analytics Technical Support with any concerns about the serviceability or operation of the detector or for help with this quick start guide.

Periodically inspect the detector and cabling for signs of physical damage. Do not use liquid cleaning agents for cleaning the flame detector. Do not use solvents or abrasive cleaners on the detector housing or optics. Clean only with microfiber cloths moistened with water or with optical grade wipes.

## WARNING

Rubbing the detector's housing or mounting may cause static discharges that can result in an explosion in a combustible atmosphere. In hazardous areas, use only a clean, damp cloth (moistened with water) to clean the mounting and detector.

The FSL100 detector has no user-serviceable parts. Honeywell Analytics recommends that the unit be checked and serviced annually by an approved Honeywell field technician.

Except for cleaning, no specific preventive maintenance is needed. Routine inspection of these items is recommended:

- Check the position and alignment of the flame detector.
- Verify that there are no potential false alarm sources in the field of view.
- Remove obstacles which restrict the field of view.
- Clean the detector window with a microfiber cloth moistened with water or with optical grade wipes.
- Ensure that the cover of the housing (with the detector window) is mounted correctly on the housing. The sensors must be visible when viewed through the detector window.
- Check the cabling and conduits from the flame detector to the controller for damage or loose connections, especially at earth (ground) points.
- Verify that the cover and the gland are secure and undamaged.
- Ensure that all fasteners and the cable gland are tight and secure.
- Perform a functional test with an FSL100-TL test lamp (in safe areas) or an FSL100-TLX test lamp (in hazardous areas).
- Clean the inner side of the detector window once a year (e.g., during a field service technician's annual inspection).

## More Information

For complete information about the installation, operation, and maintenance of the detector, refer to the *FSL100 Technical Handbook*.

## Contact Us

Honeywell Analytics  
405 Barclay Boulevard  
Lincolnshire, Illinois 60069  
Tel: +1 847 955 8200  
Toll free: +1 800 538 0363  
Fax: +1 847 955 8208  
[detectgas@honeywell.com](mailto:detectgas@honeywell.com)

