



INSTRUCTION BOOK FOR
Tensioned Advantage®
Deluxe Electrol®



Original Instructions

Disclaimer

Milestone and its affiliated corporations and subsidiaries (collectively "Milestone"), intend to make this manual accurate and complete. However, Milestone makes no claim that the information contained herein covers all details, conditions or variations, nor does it provide for every possible contingency in connection with the installation or use of this subject to change without notice or obligation of any kind. Milestone makes no representation of warranty, expressed or implied, regarding the information contained herein. Milestone assumes no responsibility for accuracy, completeness or sufficiency of the information contained in this document.

Da-Lite® is a registered trademark of Milestone AV Technologies. All rights reserved.

Important Safety Instructions

When using your video equipment, basic safety precautions should always be followed, including the following:

1. Read and understand all instructions before using.
2. Position the cord so that it will not be tripped over, pulled, or contact hot surfaces.
3. If an extension cord is necessary, a cord with a current rating at least equal to that of the appliance should be used. Cords rated for less amperage than the appliance may overheat.
4. To reduce the risk of electric shock, do not disassemble this appliance. Contact an authorized service dealer when repair work is required. Incorrect reassembly can cause electric shock when the appliance is used subsequently.
5. The use of an accessory attachment not recommended by the manufacturer may cause a risk of fire, electric shock, or injury to persons.
6. Failure to provide adequate structural strength for this component can result in serious personal injury or damage to equipment! It is the installer's responsibility to make sure the structure to which this component is attached can support the weight of all equipment. Reinforce the structure as required before installing the component.
7. Use this projection screen only for its intended use as described in these instructions. Do not use attachments not recommended by the manufacturer.

Save These Instructions

Pre-Installation

1. Carefully unpack screen and remove outer wrapping from case.
2. Make sure to recheck measurements of screen location before installation.

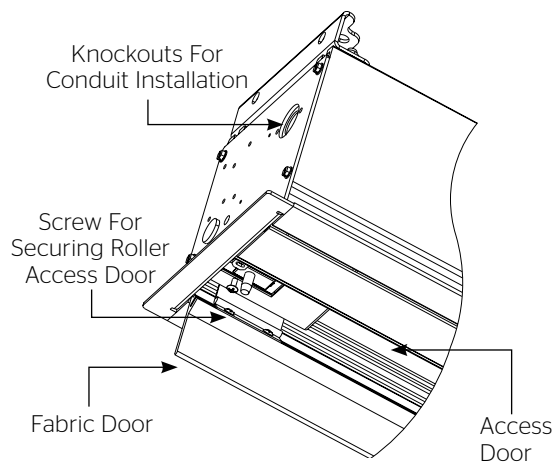

Figure 1

Case Installation

1. The case provides multiple attachment points for bolts, cables, or threaded rod. Page 7 shows threaded rod installed. The variable position-mounting bracket may be located anywhere along the length of the case. It is recommended to keep the brackets spaced evenly enough to distribute the weight of the screen.

The case has a self-trimming flange around the bottom. Ceiling tiles or drywall may be placed on top of this flange to provide a finished appearance.

2. After securing the case in the ceiling check that the case is level and plumb.
3. Use supplied 1/8" hex key and a 1/4" wrench to remove silver shipping brackets attached to slat and screen case.
4. Install electrical connections that apply to your unit. Refer to the following diagrams for proper installation. The diagrams on page 6 are for standard controls; the diagrams on page 7 are for SCB100 controls and page 8 for SCB200 controls. The terminal block for the wall switch connections is located under the metal housing surrounding the junction box. Remove two screws for access.

NOTE: Use provided knockouts for all electrical connections. DO NOT drill additional holes into screen case or end cap.

Screen And Roller Assembly Installation

If your screen was shipped with the motor and roller already installed proceed to step 6.

1. Remove the screw from each end of the access door (front door) and open the door. See figure 1.
2. Carefully unpack screen and roller assembly. Leave packing paper on the roller.
3. Place the roller assembly into the case with the motor on the left side. The limit switches should be facing down. Line up the square pin on the motor with the square hole in the bracket. Secure with cotter pin. See figure 2.
4. Lift the pin end (right end) of the roller into position and slide the bracket onto the roller pin. Tighten two nuts to secure the bracket. Secure pin end with cotter pin. See figure 3.
5. Complete electrical hook-up by snapping motor wire connector into case connector.
6. Remove shipping brackets by removing the hex head screws from aluminum slat and case. Slat should move freely. See figure 2. (Only if the roller assembly is preinstalled.)

7. Test installation by operating the screen several times. Be prepared to stop the screen. Standard Duty Cycle: 1 MIN. ON/3 MIN. OFF. The fabric door (rear door) will not close until the wall switch is placed in the up position and when the screen motor stops at its limit switch in the up direction.

⚠ CAUTION: Excessive continuous operation may cause the motor to overheat. If this happens the motor will shut off until it cools to a normal operating temperature.

⚠ ATTENTION! Le fonctionnement continu et excessif peut provoquer une surchauffe. Si cela se produit, les moteurs s'arrêteront jusqu'à qu'ils se soient refroidis à la température normale de fonctionnement.

8. Remove any shipping foam attached to the inside of the access and fabric doors before operation.
9. Run the screen down enough to open the fabric door. Close the access door and reinstall the screws to secure the door.

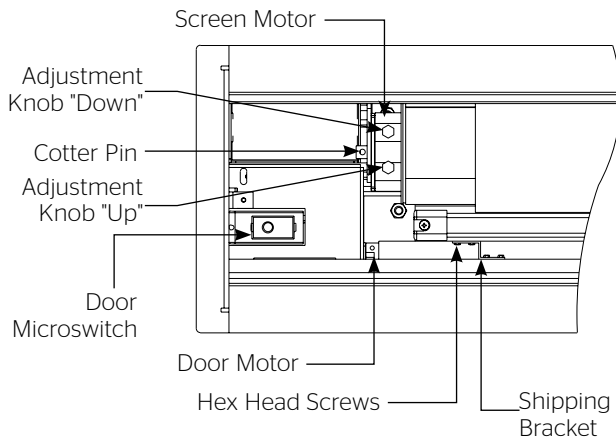

Figure 2

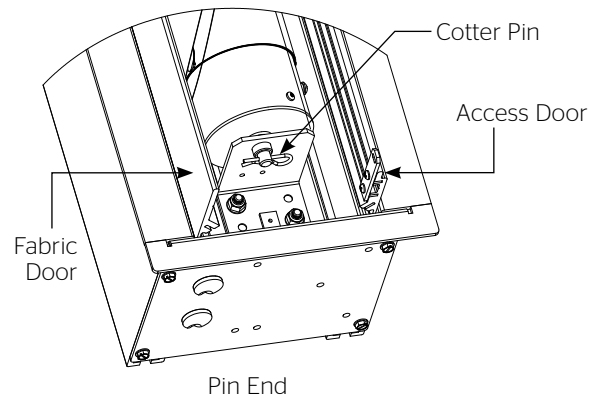

Figure 3

Screen Adjustment

NOTE: Use a screw driver or 5/32" Allen wrench to make adjustments.

More Screen Drop

1. Place operating switch in "down" position.
2. When the screen stops, turn the "down" limit knob (Fig. 2) one-quarter turn counterclockwise. Test by raising picture surface approximately two feet, then lower again. Repeat until desired picture surface position is attained.

⚠ CAUTION: Do not adjust for more drop than what was ordered. At least 1-1/2 wraps of fabric must remain on the roller. This screen comes standard with 12" black at the top.

⚠ ATTENTION! N'effectuez pas de réglage pour obtenir un déroulement supérieur à celui commandé. Au moins 1 à 1/2 tour de toile doit être maintenu sur le cylindre. Cet écran est doté de série d'une bande noire supérieure de 0 cm (0 po) ou 5 cm (2 po). Consultez la fiche technique pour plus de renseignements.

Less Screen Drop

1. Raise picture surface approximately two feet above desired level.
2. Place operating switch in "off" position.
3. Turn the "down" limit switch (Fig. 2) one-quarter turn clockwise. Test by raising picture surface approximately two feet, then lower again. Repeat until desired picture surface position is attained.

⚠ CAUTION: Adjusting the down limit switch for less drop by more than 6" can cause the screen surface to lose proper tensioning.

⚠ ATTENTION! LE FAIT D'AJOUTER NE DÉROULEZ PAS TROP L'ÉCRAN PLUS DE 15 CM (6PO) AUX INTERRUPTEURS DE FIN DE COURSE PEUT FAIRE PERDRE LA BONNE TENSION À LA SURFACE DE L'ÉCRAN.

⚠ CAUTION: Contact Da-Lite at 800-622-3737 or 574-267-8101 if door motor needs adjustment.

⚠ ATTENTION: Contactez Da-Lite au 800-622-3737 ou au 574-267-8101 au cas le moteur de porte doit être ajusté.

Tensioned Advantage® Deluxe Electrol® Installation

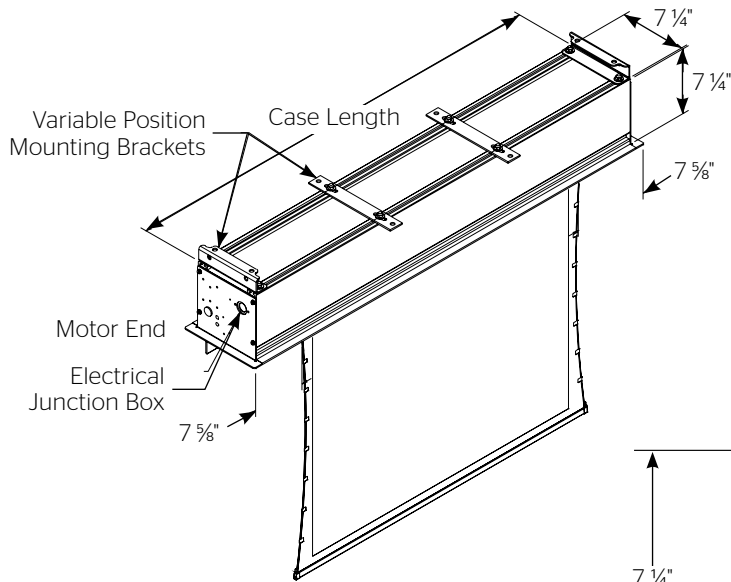

Flat Bracket Mounting Method

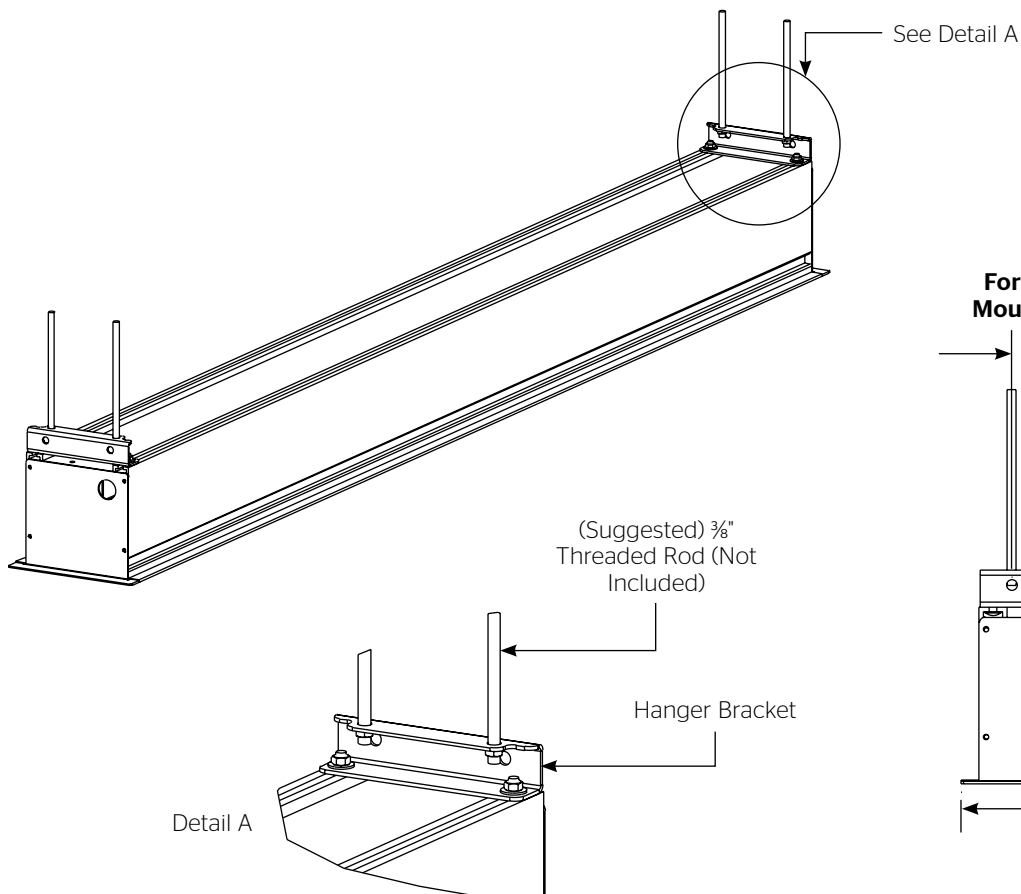
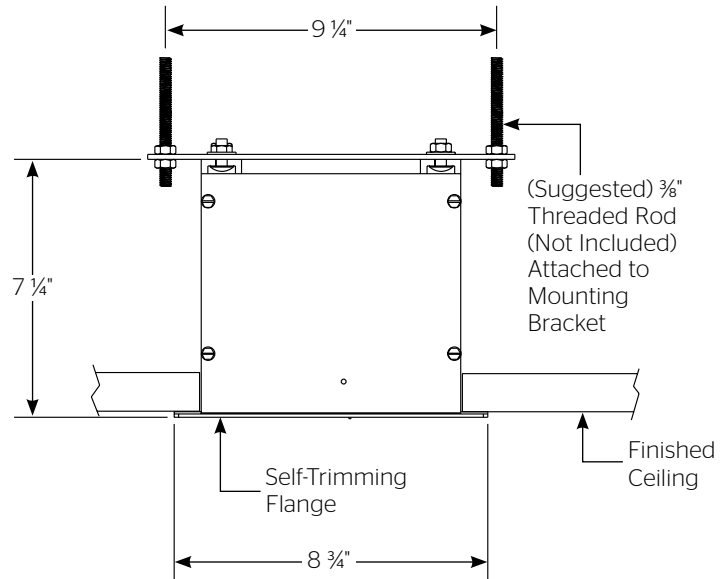

Tensioned Advantage® Deluxe Electrol® Instructions For Standard Control

120V Wiring Diagram

NOTE: Electrical connections on left end of case.

Use provided knockouts for all electrical connections. DO NOT drill additional holes into screen case or end cap.

NOTE: 20-24AWG Wire Recommended For Connecting Wall Switch to the Dual Motor Controller

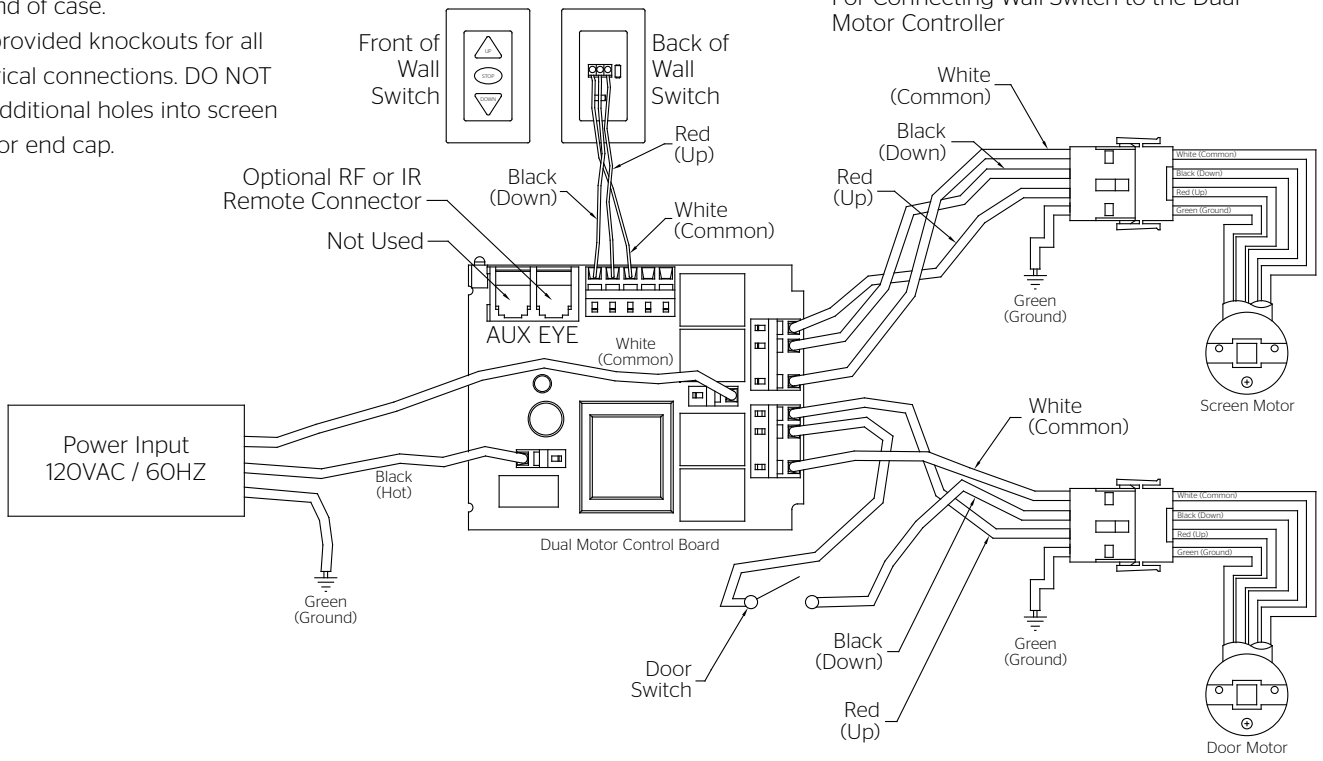

220V Wiring Diagram

NOTE: Electrical connections on left end of case.

Use provided knockouts for all electrical connections. DO NOT drill additional holes into screen case or end cap.

NOTE: 20-24AWG Wire Recommended For Connecting Wall Switch to the Dual Motor Controller

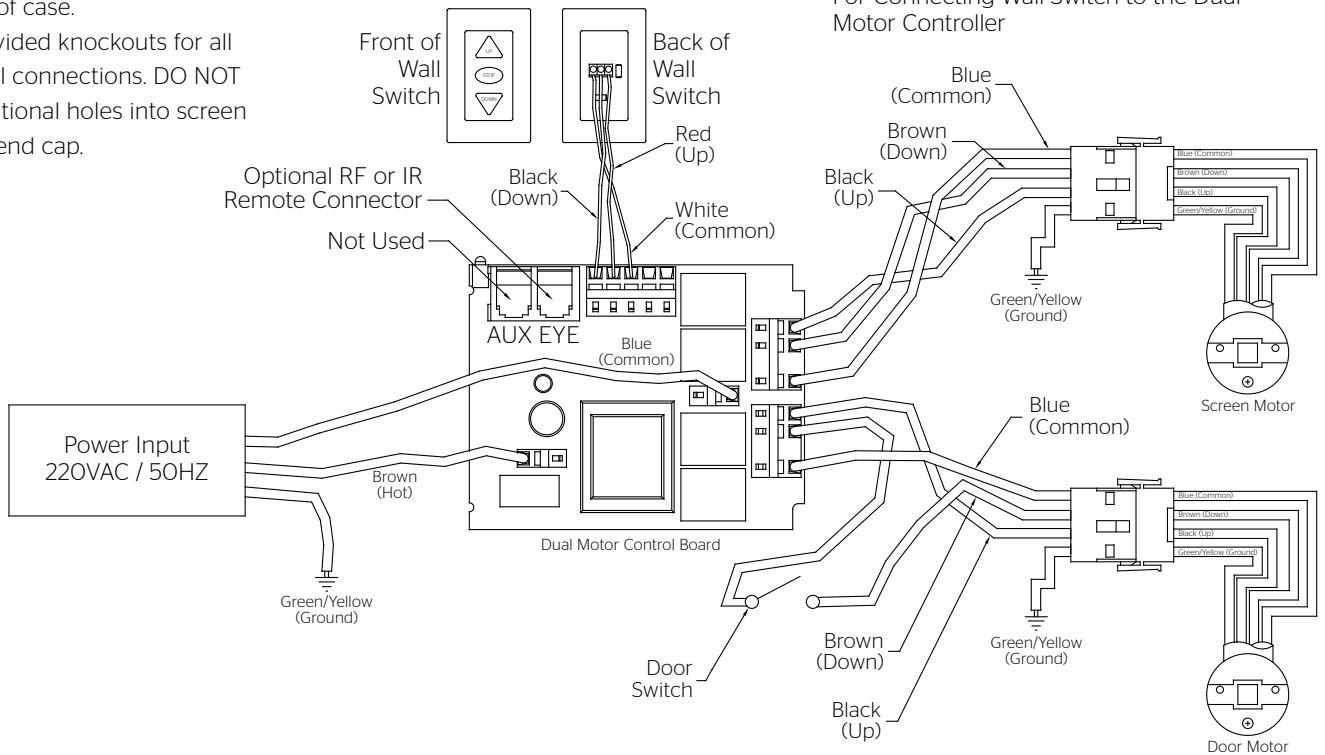

120V Wiring Diagram

NOTE: Electrical connections on left end of case.

Use provided knockouts for all electrical connections. DO NOT drill additional holes into screen case or end cap.

NOTE: 20-24AWG Wire Recommended For Connecting Wall Switch to the Dual Motor Controller

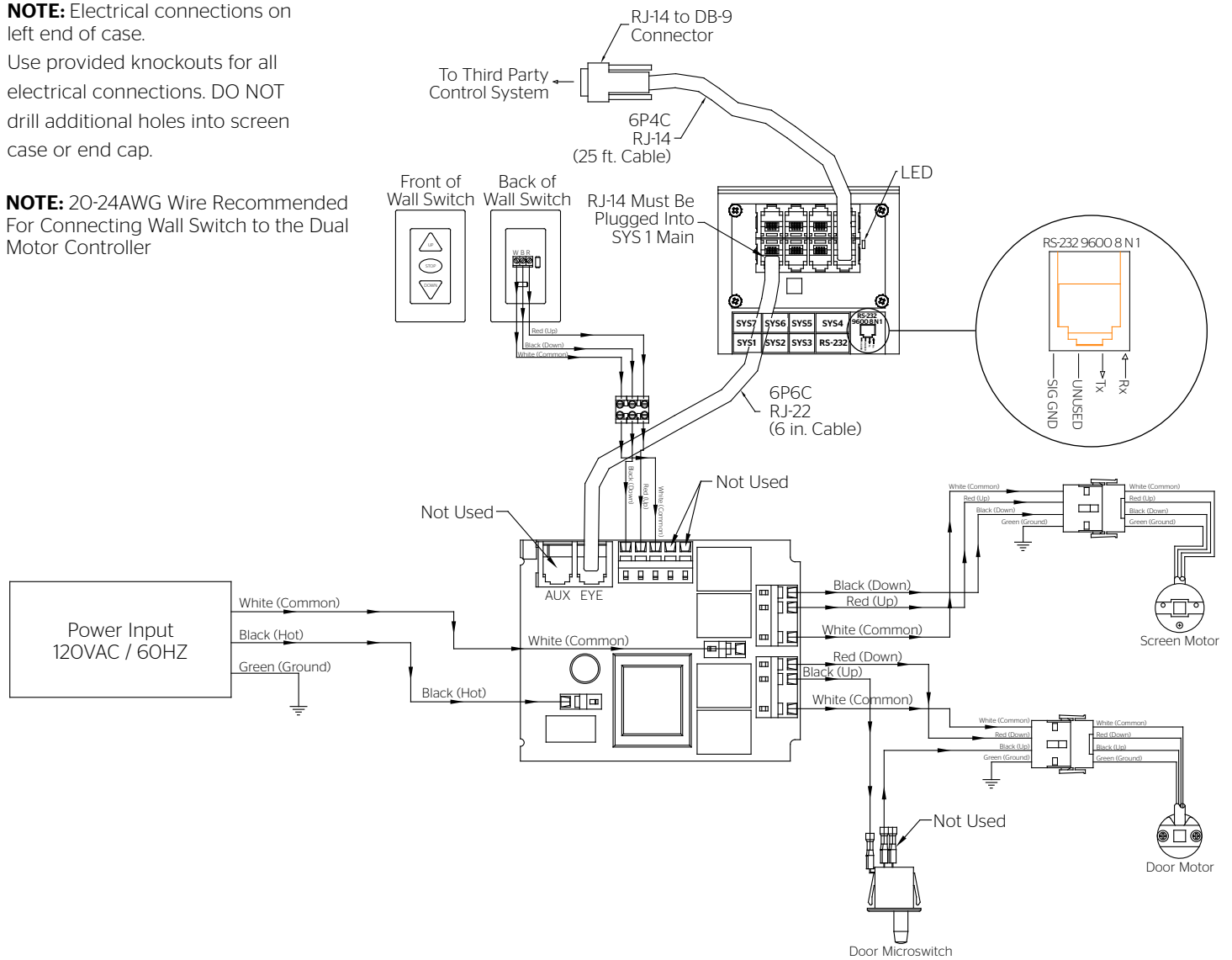

Communication Instructions

The connection settings for the SCB-100 are 9600 Baud Rate, 8 Data Bits, None Parity, 1 stop bit and XON/XOFF Flow Control. The control is NOT Bi-Directional, but it will give a response to commands sent.

1. When the SCB-100 unit first powers on it will send back the (Version, X-on). The LED on the SCB-100 unit will flash green, red, green and red.
2. To send the screen down the command is `"*1c04;"`
3. To send a stop command to the screen is `"*1s04;"`
4. To send the screen up the command is `"*1o04;"`
5. The unit will respond with a "LF" if command was good. It will respond with "U" if the command was not understood.

220V Wiring Diagram

NOTE: Electrical connections on left end of case.

Use provided knockouts for all electrical connections. DO NOT drill additional holes into screen case or end cap.

NOTE: 20-24AWG Wire Recommended For Connecting Wall Switch to the Dual Motor Controller

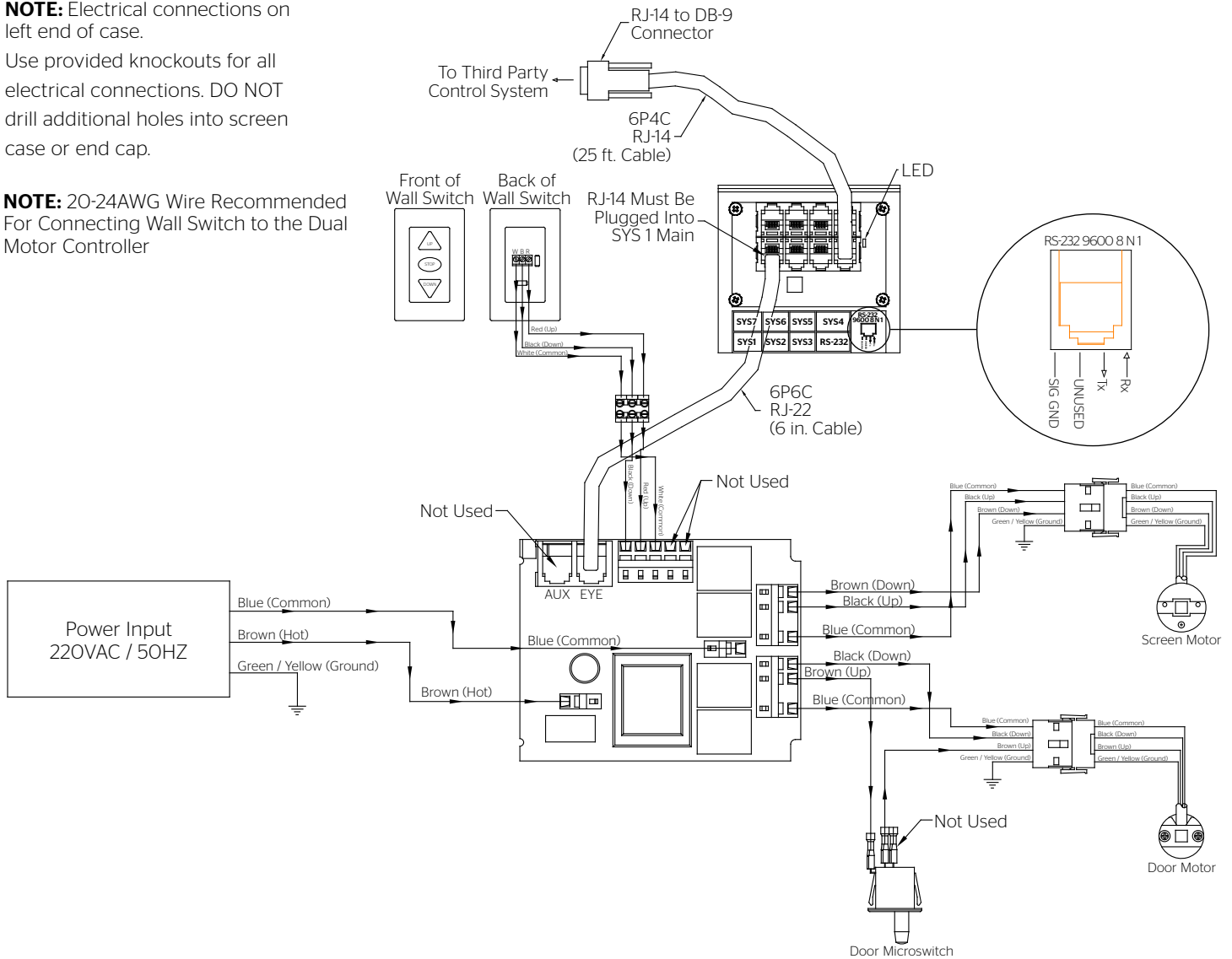

Communication Instructions

The connection settings for the SCB-100 are 9600 Baud Rate, 8 Data Bits, None Parity, 1 stop bit and XON/XOFF Flow Control. The control is NOT Bi-Directional, but it will give a response to commands sent.

1. When the SCB-100 unit first powers on it will send back the (Version, X-on). The LED on the SCB-100 unit will flash green, red, green and red.
2. To send the screen down the command is "*1c04;"
3. To send a stop command to the screen is "*1s04;"
4. To send the screen up the command is "*1o04;"
5. The unit will respond with a "LF" if command was good. It will respond with "U" if the command was not understood.

Troubleshooting

| Symptom | Cause | Solution |
|---|--|---|
| <p>If screen is not responding properly and SCB100 or SCB200 controls are used, contact the factory for troubleshooting assistance.</p> <p>Screen will not operate or will not go "down". Motor does not hum.</p> | Incorrect line voltage. | Verify 115-125V (or 220-240V). If insufficient voltage, rewire incoming electric line. |
| | Blown facility fuse. | Replace facility fuse. |
| | Tripped facility circuit breaker. | Reset facility circuit breaker. |
| | No power to operating switch or junction box. | Check above. Tighten all loose wire connections. Recheck wiring. See installation instructions. "Down" Position Check for power across black and white leads. |
| | Power at junction box. Thermal overload tripped. | Let motor cool down for 15 minutes. Try again. |
| | Broken wire in the "down" position. | Check for continuity. |
| | Defective motor, limit switch or capacitor. | Replace motor assembly. NOTE: Motor is a sealed assembly. |
| Motor hums. | Capacitor burned out. | Replace motor assembly. |
| <p>Screen will not move upward. Motor does not hum.</p> | Incorrect line voltage. | Verify 115-125V (or 220-240V). If insufficient voltage, rewire incoming electric line. |
| | Blown facility fuse. | Replace facility fuse. |
| | Tripped facility circuit breaker. | Reset facility circuit breaker. |
| | No power to operating switch or junction box. | Check above. Tighten all loose wire connections. See above "Up" Position Check for power across red and white leads.. |
| | Open door limit switch. | Replace switch. |
| | Power at junction box. Thermal overload tripped. | Let motor cool down for 15 minutes. Try again. |
| | Broken wire in the "up" position. | Check for continuity. |
| | Defective motor, limit switch or capacitor. | Replace motor assembly. NOTE: Motor is a sealed assembly. |
| Motor hums. | Capacitor burned out. | Replace motor assembly. |

Troubleshooting (continued)

| Symptom | Cause | Solution |
|---|---|--|
| Door will not open. | Hinge is bound or has a foreign substance on it which does not allow it to open by gravity. | Check installation to free door. Clear any foreign substance; i.e., paint or plaster from hinge. |
| | No power. | See above. |
| Door does not close. | Open door limit switch. | Replace switch. |
| | No power from screen motor. | Replace screen motor |
| "Down" limit switch incorrect.. | "Down" limit switch out of adjustment. | See installation instructions. |
| Noise. NOTE: Screen will operate with a low-pitched hum. | Buzzing noise. | Adjust door limit switch (too far down). |
| | Gear noise | Replace motor assembly. |
| Coasting. | Defective brake. | Replace motor assembly. |
| Roller displaced from mounting bracket. | Pin end slipped out of nylon bearing | Realign pin end bracket. |
| Fabric hangs crooked. | Screen not installed properly. | Check for level and plumb. |
| | Fabric is damaged. | Replace fabric. |
| Door closes before screen is all the way up. | Screen "up" limit out of adjustment. | Adjust "up" limit (call factory for instructions). |
| Door opens but screen does not operate. | Loose wire. | Check all wiring and connections. |

LIMITED FIVE YEAR WARRANTY ON DA-LITE TENSIONED ADVANTAGE® DELUXE ELECTROL®, ADVANTAGE® DELUXE ELECTROL®, TENSIONED ADVANTAGE® ELECTROL®, ADVANTAGE® ELECTROL®, TENSIONED LARGE ADVANTAGE® DELUXE ELECTROL®, LARGE ADVANTAGE® DELUXE ELECTROL®, TENSIONED LARGE ADVANTAGE® ELECTROL®, LARGE ADVANTAGE® ELECTROL®, TENSIONED CONTOUR® ELECTROL® AND CONTOUR® ELECTROL® PRODUCTS ONLY

Milestone AV Technologies LLC warrants these Da-Lite branded products to the original purchaser only, to be free from defects in materials and workmanship for a period of five (5) years from the date of purchase by the original purchaser; provided they are properly operated according to Da-Lite's instructions and are not damaged due to improper handling or treatment after shipment from the factory.

This warranty does not apply to equipment showing evidence of misuse, abuse or accidental damage, or which has been tampered with or repaired by a person other than authorized Da-Lite personnel.

Da-Lite's sole obligation under this warranty shall be to repair or to replace (at Da-Lite's option) the defective part of the merchandise. Returns for service should be made to your Da-Lite dealer. If it is necessary for the dealer to return the screen or part to Da-Lite, transportation expenses to and from Da-Lite are payable by the purchaser and Da-Lite is not responsible for damage in shipment.

To protect yourself against damage or loss in transit, insure the product and prepay all transportation expenses.

TO THE MAXIMUM EXTENT PERMITTED BY APPLICABLE LAW, THIS WARRANTY IS IN LIEU OF ALL OTHER WARRANTIES, EXPRESS OR IMPLIED, INCLUDING WARRANTIES AS TO FITNESS FOR USE AND MERCHANTABILITY. Any implied warranties of fitness for use, or merchantability, that may be mandated by statute or rule of law are limited to the five (5) year warranty period. This warranty gives you specific legal rights, and you may also have other rights, which vary from state-to-state. **TO THE MAXIMUM EXTENT PERMITTED BY APPLICABLE LAW, NO LIABILITY IS ASSUMED FOR EXPENSES OR DAMAGES RESULTING FROM INTERRUPTION IN OPERATION OF EQUIPMENT, OR FOR INCIDENTAL, DIRECT, OR CONSEQUENTIAL DAMAGES OF ANY NATURE.**

In the event that there is a defect in materials or workmanship of a Da-Lite product, you may contact our Customer Care Specialists at 3100 North Detroit Street, Warsaw, IN 46582, (574) 267-8101, (800) 622-3737.

IMPORTANT: THIS WARRANTY SHALL NOT BE VALID AND DA-LITE BRANDED PRODUCTS SHALL NOT BE BOUND BY THIS WARRANTY IF THE PRODUCT IS NOT OPERATED IN ACCORDANCE WITH THE DA-LITE WRITTEN INSTRUCTIONS.

Keep your sales receipt to prove the date of purchase and your original ownership.



A BRAND OF MILESTONE AV TECHNOLOGIES | www.milestone.com

P 800.622.3737 / 574.267.8101 **F** 877.325.4832 / 574.267.7804

E info@da-lite.com

In British Columbia, Milestone AV Technologies ULC carries on business as MAVT Milestone AV Technologies ULC.

©2018 Milestone AV Technologies. DL-0176 (Rev. 3) 10.14.

Da-Lite is a registered trademarks of Milestone AV Technologies. All other brand names or marks are used for identification purposes and are trademarks of their respective owners.

All patents are protected under existing designations. Other patents pending.

34200218