

Instruction Book for
LARGE ADVANTAGE® ELECTROL®



IMPORTANT SAFETY INSTRUCTIONS

When using your video equipment, basic safety precautions should always be followed, including the following:

1. Read and understand all instructions before using.
2. Position the cord so that it will not be tripped over, pulled, or contact hot surfaces.
3. If an extension cord is necessary, a cord with a current rating at least equal to that of the appliance should be used. Cords rated for less amperage than the appliance may overheat.
4. To reduce the risk of electric shock, do not disassemble this appliance. Contact an authorized service dealer when repair work is required. Incorrect reassembly can cause electric shock when the appliance is used subsequently.
5. The use of an accessory attachment not recommended by the manufacturer may cause a risk of fire, electric shock, or injury to persons.

TOOLS REQUIRED FOR INSTALLATION

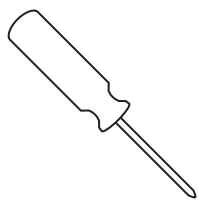

#2 Phillips Screwdriver



3/4" Open Wrench
or Socket Driver

PRE-INSTALLATION

1. Carefully unpack case from shipping crate.
2. Set aside the Installation Kit. Items inside will be used during installation.
3. Make sure to recheck measurement of case for proper installation clearance.
4. Remove any protective foam from case.
5. If necessary, adjust hanger brackets with a 3/4" open wrench or socket driver.

CASE INSTALLATION

1. The case provides multiple attachment points for bolts, cables, or threaded rod. Page 4 shows threaded rod installed. The variable position-mounting bracket may be located anywhere along the length of the case. It is recommended to keep the brackets spaced evenly enough to distribute the weight of the screen. One mounting bracket is required for every 4' of case length.

2. Tighten bolts until trim flange is flush with ceiling.

NOTE: For proper operation, screen assembly must be level after installation.

3. Remove 2 screws to open junction box. Install electrical connections that apply to your unit. Make sure to review the wiring diagram for proper hook up. Replace junction box cover and secure with 2 screws.

NOTE: Please Note: Motor Operator Projection Screen Models LADT, LADDT, LAD and LADD must be installed in accordance with the requirements of the Local Building

Codes, the Canadian Electrical Code (CEC), CAN/CSA C22.1 and the National Electric Code (NEC), NFPA 70. An appropriate disconnect device shall be provided as part of the building installation.

If your case was ordered in advance of the screen and roller assembly, your installation is now complete. Continue to step 4 if your Large Advantage Electrol was ordered as a complete unit.

4. Carefully remove paper and tape from roller assembly

⚠ CAUTION! DO NOT USE A KNIFE OR SHARP OBJECT TO CUT TAPE; YOU WILL DAMAGE THE SCREEN. PULL ORANGE STRING.

5. Test installation by running screen up and down a few times. Be prepared to stop screen should any objects obstruct the movement of the screen. To prevent damage to the motor, the standard duty cycle is 1 minute on and 3 minutes off.

SCREEN AND ROLLER ASSEMBLY INSTALLATION

Tools required for screen and roller assembly:

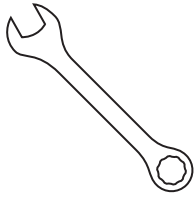

9/16" Open Wrench
or Socket Driver

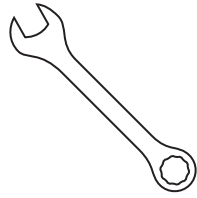

1/2" Open Wrench
or Socket Driver

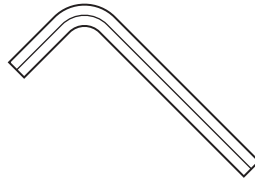

5/32" Hex Key

If your screen was shipped with the motor and roller already installed proceed to step 7.

1. Remove the access door. First, remove the 2 bolts from each end with a 9/16" open wrench or socket driver. Next, use a 5/32" hex key to remove the two screws in the center of the access door. This will allow the door to drop open on the hinges (Figure 1).
 2. Carefully unpack screen and roller assembly. Leave packing paper on the roller.
 3. Remove the square peg bracket from the motor end of the roller assembly (Figure 2).
 4. Remove the safety clip from the motor attachment bracket located in the motor end of the screen housing.
 5. Use a 1/2" open wrench or socket driver to loosen the four bolts that secure pin end mounting bracket into housing. Lift pin end of roller into position and slide the bracket into the roller pin. Tighten all four bolts. Slide the pin end bracket towards the end of the case (Figure 3).
 6. Place the roller assembly into the case with the motor on the left side. The limit switches should be facing down. Line up the head of the motor with the motor attachment bracket.
 7. Complete electrical hook-up by snapping motor 1/3 wire connectors into case connectors (Figure 2).
 8. Return to motor end and insert safety clip over casting bracket to secure motor end.
 9. Carefully remove tape strips securing picture surface around roller. Slat should move freely. (Only if the roller assembly is pre installed.)
- ⚠ CAUTION! DO NOT CUT TAPE ON FABRIC WITH A KNIFE OR ANY SHARP TOOL. REMOVE BY HAND.**
10. Test installation by running screen up and down a few times. Be prepared to stop screen should any objects obstruct the movement of the screen. To prevent damage to the motor, the standard duty cycle is 1 minute on and 3 minutes off.
 11. Re-install the access door. Procedure is the reverse of step 1 listed above.

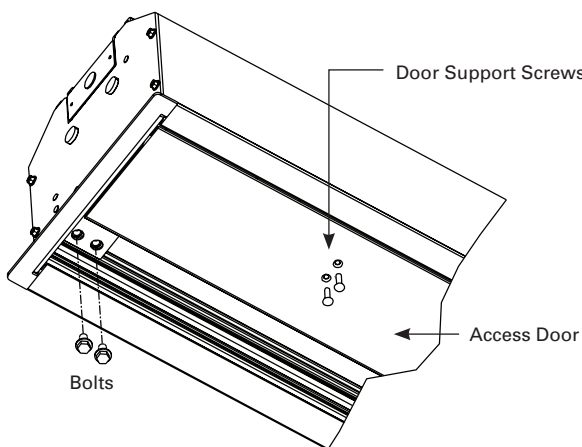

Figure 1

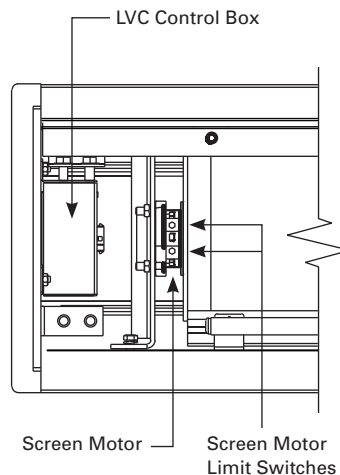

Figure 2

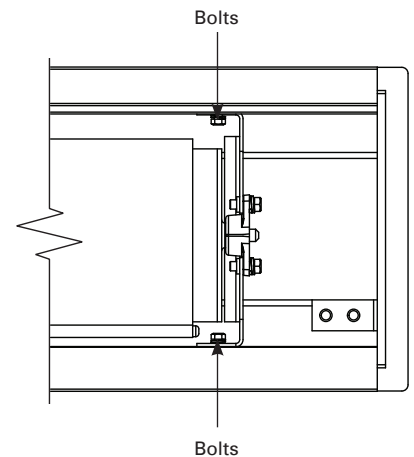
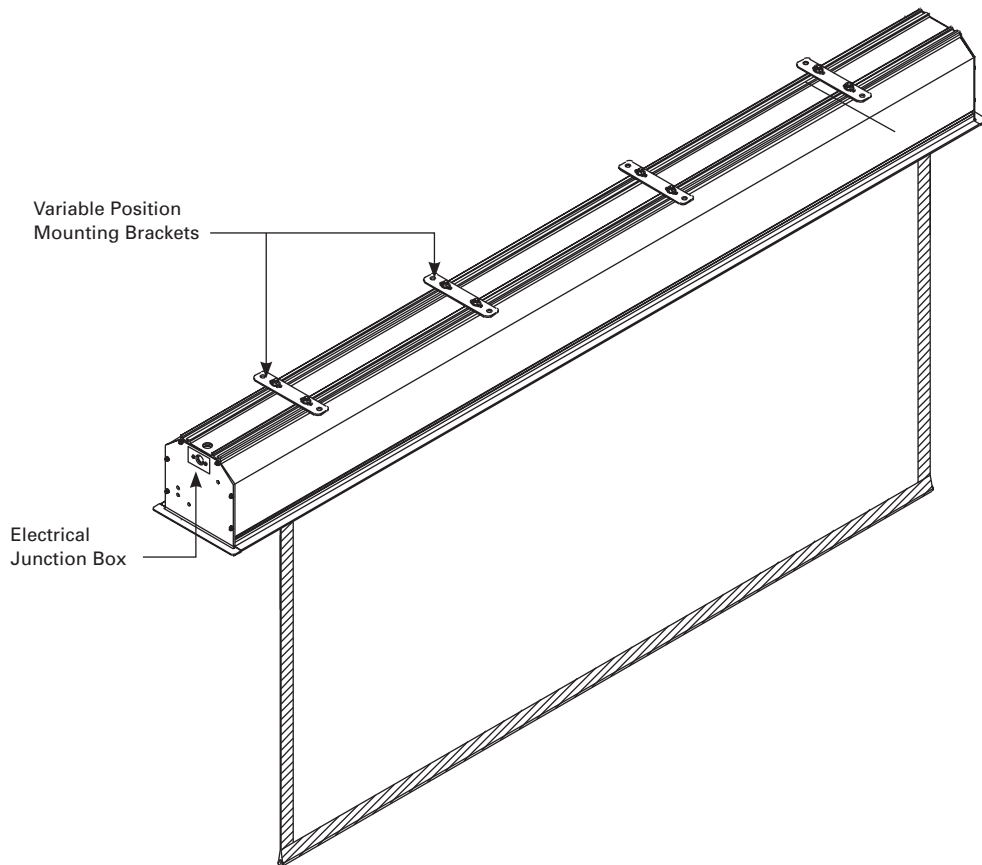
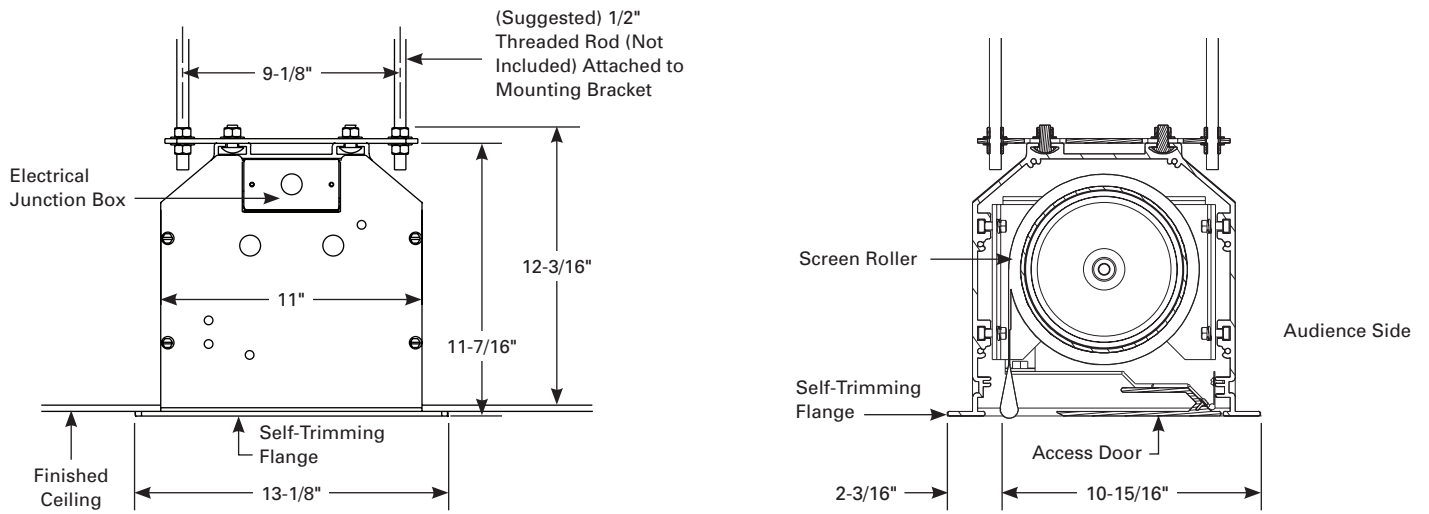

Figure 3

LARGE ADVANTAGE® ELECTROL® INSTALLATION



SCREEN ADJUSTMENT

Surface travel is stopped automatically in the fully opened and closed positions by limit switches that are properly adjusted at Da-Lite. Should it be necessary to adjust for more or less drop of picture, proceed in the following manner:

NOTE: Use a screw driver or 5/32" Allen wrench to make adjustments.

MORE SCREEN DROP

1. Place operating switch in "down" position.
2. When the screen stops, turn the white "down" limit knob one-quarter turn counterclockwise (Figure 4). Test by raising picture surface approximately two feet, then lower again. Repeat until desired picture surface position is attained.

⚠ CAUTION: DO NOT ADJUST FOR MORE DROP THAN WHAT WAS ORDERED. AT LEAST 1-1/2 WRAPS OF FABRIC MUST REMAIN ON THE ROLLER. THIS SCREEN COMES STANDARD WITH 0" OR 2" BLACK AT THE TOP. SEE THE SPECIFICATION DATA SHEET FOR DETAILS.

LESS SCREEN DROP

1. Raise picture surface approximately two feet above desired level.
2. Place operating switch in "off" position.
3. Turn the white "down" limit switch one-quarter turn clockwise (Figure 4). Test by raising picture surface approximately two feet, then lower again. Repeat until desired picture surface position is attained.

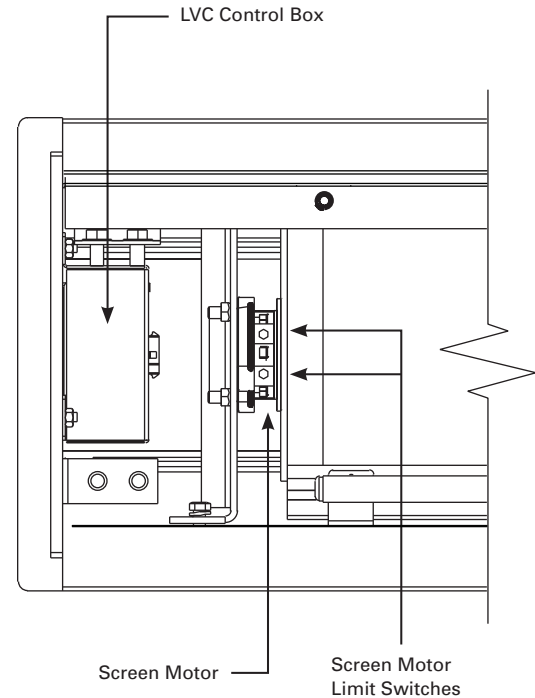
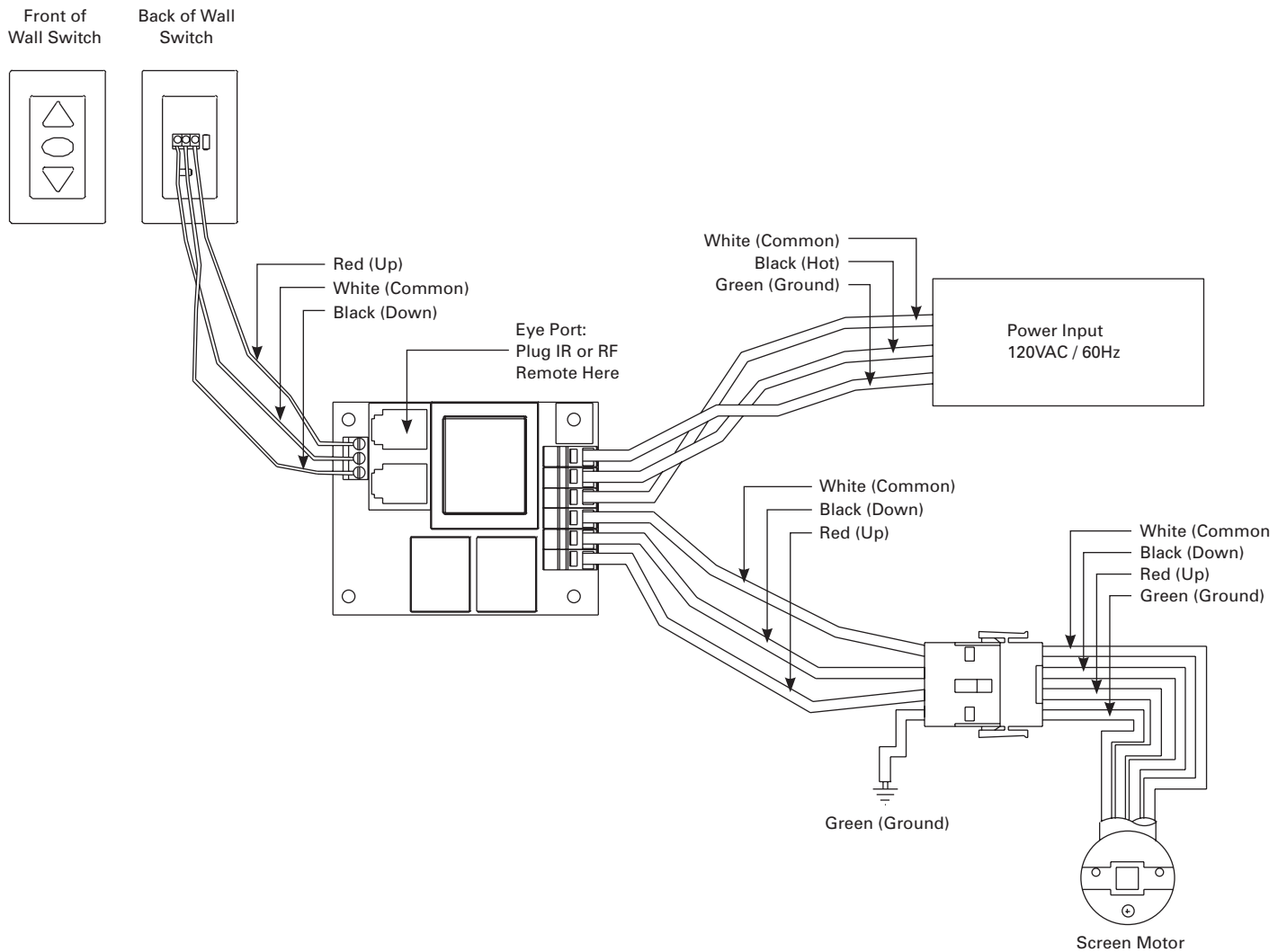

Figure 4

120V WIRING DIAGRAM WITH OPTIONAL BUILT-IN LOW VOLTAGE CONTROL

NOTE: 20-24 AWG wire recommended for connecting wall switch to low voltage controller.

**⚠ CAUTION: DO NOT USE 3-POSITION HIGH VOLTAGE
ROCKER SWITCH WITH THIS UNIT! THIS WILL DAMAGE
THE LOW VOLTAGE CONTROL BOARD.**



240V WIRING DIAGRAM WITH OPTIONAL BUILT-IN LOW VOLTAGE CONTROL

NOTE: 20-24 AWG wire recommended for connecting wall switch to low voltage controller.

**⚠ CAUTION: DO NOT USE 3-POSITION HIGH VOLTAGE
ROCKER SWITCH WITH THIS UNIT! THIS WILL DAMAGE
THE LOW VOLTAGE CONTROL BOARD.**

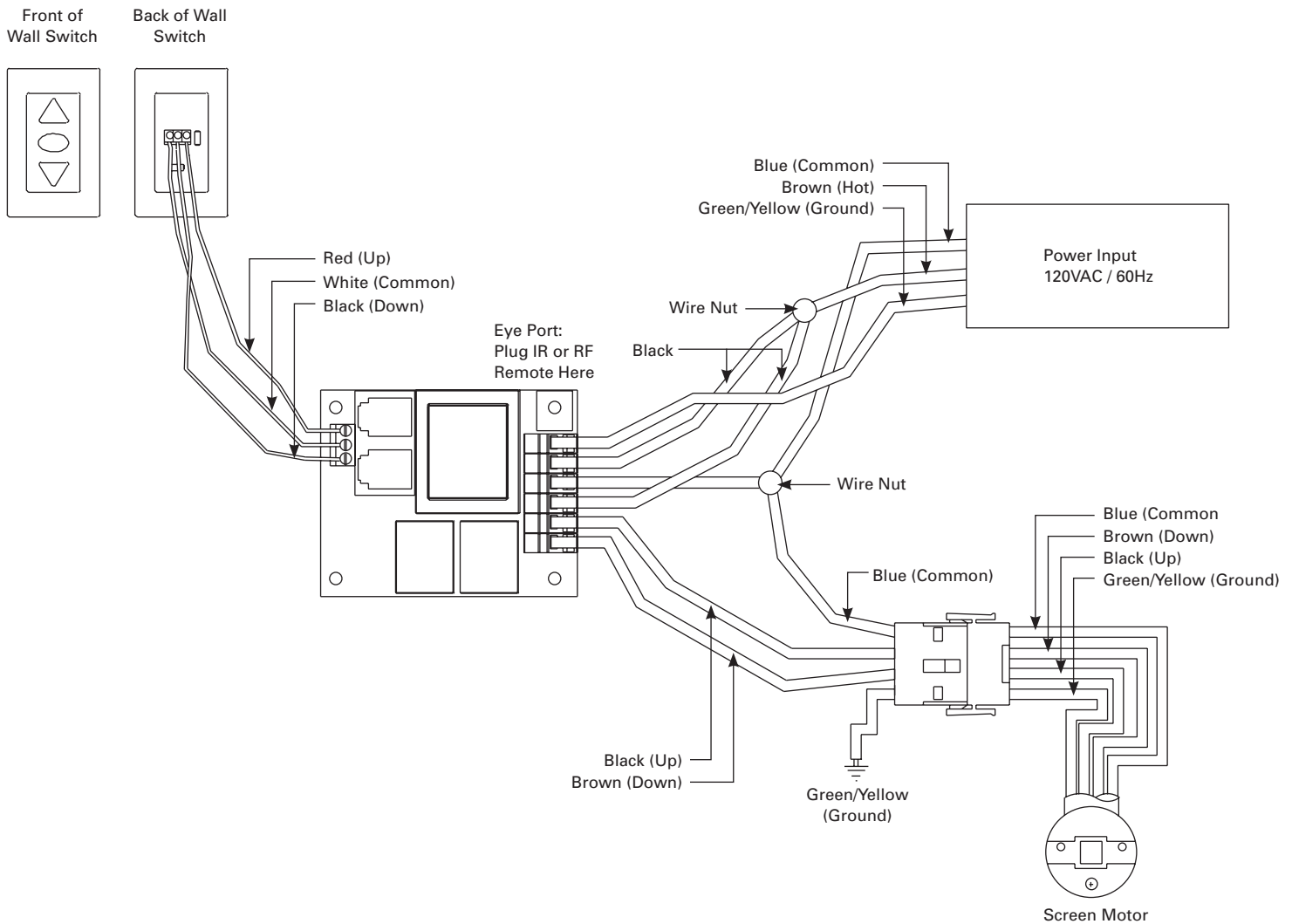

TROUBLESHOOTING

Visit www.da-lite.com/products/tutorials.php to find installation and troubleshooting tutorials. You will also find a link to Live Chat for interactive support.

You can contact us by email at info@da-lite.com or by phone at 800.622.3737 or 574.267.8101 with any additional troubleshooting questions.

Symptom	Cause	Solution
Screen will not operate and motor does not hum.	Incorrect line voltage.	Verify 115-125V (or 220-240V). If insufficient voltage, rewire incoming electric line.
	Blown fuse.	Replace fuse.
	Tripped circuit breaker.	Reset circuit breaker.
	No power to operating switch or junction.	Check above. Tighten all loose wire connections. Correct any improper connections. Down Position Check for power across black and white leads. Up Position Check for power across red and white leads.
Screen will not operate and motor does not hum. Power at junction box.	Thermal overload tripped.	Let motor cool down for 15 minutes. Try again.
	Broken wire in the "down" or "up" position.	Check for continuity. Cut off old splice and reconnect.
	Defective motor, limit switch or capacitor.	Replace motor assembly. NOTE: Motor is a sealed assembly.
	Capacitor burned out.	Replace motor assembly.
Screen does not stop at correct position.	Limit switch out of adjustment.	See Screen Adjustment section.
Noise. NOTE: Screen will operate with a low pitched hum.	Squeaking, rubber end plug rubbing on motor.	Center roller in case.
	Grinding. Foreign object in screen rubbing on roller or fabric.	Remove.
	Gear noise.	Replace motor assembly.
Coasting.	Defective brake.	Replace motor assembly.
Fabric hangs crooked.	Screen not installed properly.	Check for level and plumb.
	Fabric has backed up inside case.	Adjust "down" limit switch slowly until roller is exposed and wrinkle comes out, then readjust for proper drop.
	Fabric is damaged.	Replace fabric.

LIMITED FIVE YEAR WARRANTY ON DA-LITE LARGE ADVANTAGE® ELECTROL® PRODUCTS ONLY

Da-Lite Screen Company LLC warrants these products to the original purchaser only, to be free from defects in materials and workmanship for a period of five (5) years from the date of purchase by the original purchaser provided they are properly operated according to Da-Lite's instructions and are not damaged due to improper handling or treatment after shipment from the factory.

This warranty does not apply to equipment showing evidence of misuse, abuse or accidental damage, or which has been tampered with or repaired by a person other than authorized Da-Lite personnel.

Da-Lite's sole obligation under this warranty shall be to repair or to replace (at Da-Lite's option) the defective part of the merchandise. Returns for service should be made to your Da-Lite dealer. If it is necessary for the dealer to return the screen or part to Da-Lite, transportation expenses to and from Da-Lite are payable by the purchaser and Da-Lite is not responsible for damage in shipment. To protect yourself against damage or loss in transit, insure the product and prepay all transportation expenses.

THIS WARRANTY IS IN LIEU OF ALL OTHER WARRANTIES, EXPRESS OR IMPLIED, INCLUDING WARRANTIES AS TO FITNESS FOR USE AND MERCHANT ABILITY. Any implied warranties of fitness for use, or merchantability, that may be mandated by statute or rule of law are limited to the five (5) year warranty period. This warranty gives you specific legal rights, and you may also have other rights, which vary from state-to-state. **NO LIABILITY IS ASSUMED FOR EXPENSES OR DAMAGES RESULTING FROM INTERRUPTION IN OPERATION OF EQUIPMENT, OR FOR INCIDENTAL, DIRECT, OR CONSEQUENTIAL DAMAGES OF ANY NATURE.**

In the event that there is a defect in materials or workmanship of a Da-Lite product, you may contact our Sales Partners at PO Box 137, Warsaw, IN 46581-0137, 574.267.8101, 800.622.3737.

IMPORTANT: THIS WARRANTY SHALL NOT BE VALID AND DA-LITE SHALL NOT BE BOUND BY THIS WARRANTY IF THE PRODUCT IS NOT OPERATED IN ACCORDANCE WITH DA-LITE'S WRITTEN INSTRUCTIONS.

Keep your sales receipt to prove the date of purchase and your original ownership.



A Milestone AV Technologies Brand
3100 North Detroit Street
Post Office Box 137
Warsaw, Indiana 46581-0137
P: 574.267.8101 or 800.622.3737
F: 574.267.7804 or 877.325.4832
E: info@da-lite.com

www.da-lite.com

DL-0118 12.12

©2012 Da-Lite Screen Company LLC. Printed in U.S.A.

35926