

Aruba Instant On AP17 Access Point

Installation Guide

The Aruba Instant On AP17 access points support IEEE 802.11ac standards for high-performance WLAN, and are equipped with two radios, which provide network access and monitor the network simultaneously. Multiple-in, Multiple-out (MIMO) technology allows these access points to deliver high-performance 802.11n 2.4 GHz and 802.11ac 5 GHz functionality, while also supporting 802.11a/b/g wireless services.

Package Contents

- 1 x AP17 access point
- 1 x Wall mount bracket (solid surface)
- 1 x Cable gland
- 1 x Copper lug
- 1 x M4x6 screw
- 1 x M6x45 screw



Inform your supplier if there are any incorrect, missing, or damaged parts. If possible, retain the carton, including the original packing materials. Use these materials to repack and return the unit to the supplier if needed.

Hardware Overview

Figure 1 AP17 Access Point

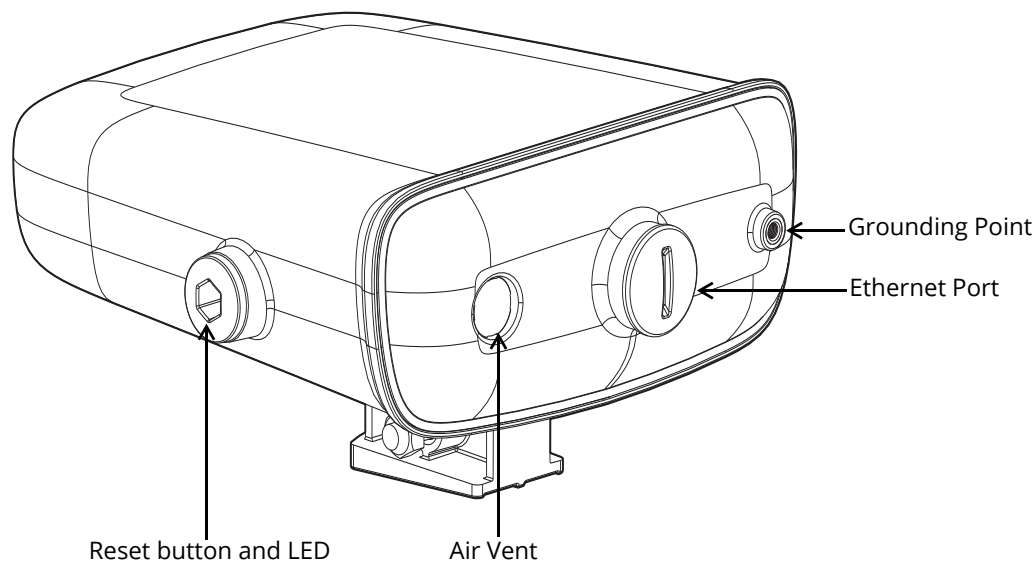

LED

The AP17 access point is equipped with a LED that indicates the system status of the device. .

Table 1 AP17 Access Point LED Status

LED	Color/State	Meaning
System LED	No Lights	Device has no power
	Blinking Green	Device is starting
	Alternating Green/Amber	Device is ready for setup
	Solid Green	Device is ready
	Solid Amber	Device has detected a problem
	Solid Red	Device has an issue- immediate action required

Reset Button

The reset button located on the bottom of the device can be used to reset the access point to factory default settings or turn off/on the LED display.

There are two ways to reset the access point to factory default settings:

Reset the AP during normal operation

Press and hold down the reset button using a small, narrow object such as a paper clip for more than 10 seconds during normal operation.

Reset the AP while powering up

1. Press and hold down the reset button using a small, narrow object such as a paper clip while the access point is not powered on.
2. Connect the power supply to the access point while the reset button is being held down.
3. Release the reset button on the access point after 15 seconds.

To turn off/on the LED display, press and release the reset button using a small, narrow object, such as a paperclip for less than 10 seconds during normal operation of the access point.

Ethernet Ports

The AP17 access point is equipped with one 10/100/1000Base-T auto-sensing, MDI/MDX Ethernet port (E0) for wired network connectivity. This port supports IEEE 802.3af Power over Ethernet (PoE), accepting 48Vdc (nominal) as a standard defined Powered Device (PD) from a Power Sourcing Equipment (PSE) such as a PoE midspan injector, or network infrastructure that supports PoE.

The port has an RJ-45 female connectors with the pin-out shown in [Figure 2](#).

Figure 2 Gigabit Ethernet Port Pin-Out

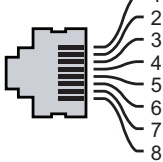
1000Base-T Gigabit Ethernet Port	RJ-45 Female Pin-Out	Signal Name	Function
		1 BI_DA+	Bi-directional pair +A, POE Negative
		2 BI_DA-	Bi-directional pair -A, POE Negative
		3 BI_DB+	Bi-directional pair +B, POE Positive
		4 BI_DC+	Bi-directional pair +C, POE Positive
		5 BI_DC-	Bi-directional pair -C, POE Positive
		6 BI_DB-	Bi-directional pair -B, POE Positive
		7 BI_DD+	Bi-directional pair +D, POE Negative
		8 BI_DD-	Bi-directional pair -D, POE Negative

Grounding Point

Always remember to protect the access point by installing grounding lines. The ground connection must be complete before connecting power to the access point enclosure.

Before You Begin

Refer to the sections below before beginning the installation process.



The AP17 access point is designed in compliance with governmental requirements so that only authorized network administrators can change the settings.

Identifying Specific Installation Locations

Each location should be as close as possible to the center of the intended coverage area and should be free from obstructions or obvious sources of interference. These RF absorbers/reflectors/interference sources will impact RF propagation and should be accounted for during the planning phase and adjusted.



Use of this equipment adjacent to or stacked with other equipment should be avoided because it could result in improper operation. If such use is necessary, this equipment and the other equipment should be observed to verify that they are operating normally.

Identifying Known RF Absorbers/Reflectors/Interference Sources

Identifying known RF absorbers, reflectors, and interference sources while in the field during the installation phase is critical. Make sure that these sources are taken into consideration when you attach an access point to its fixed location.

RF absorbers include:

- Cement/concrete—Old concrete has high levels of water dissipation, which dries out the concrete, allowing for potential RF propagation. New concrete has high levels of water concentration in the concrete, blocking RF signals.
- Natural Items—Fish tanks, water fountains, ponds, and trees
- Brick

RF reflectors include:

- Metal Objects—Metal pans between floors, rebar, fire doors, air conditioning/heating ducts, mesh windows, blinds, chain link fences (depending on aperture size), refrigerators, racks, shelves, and filing cabinets.
- Do not place an access point between two air conditioning/heating ducts. Make sure that access points are placed below ducts to avoid RF disturbances.

RF interference sources include:

- Microwave ovens and other 2.4 or 5 GHz objects (such as cordless phones)
- Cordless headset such as those used in call centers or lunch rooms

Outdoor Planning and Deployment Considerations

Prior to deploying an outdoor wireless network, the environment must be evaluated to plan for a successful WLAN deployment. Successfully evaluating the environment enables the proper selection of routers and antennas and assists in the determination of their placement for optimal RF coverage.

Access Point Installation



Use of accessories, transducers and cables other than those specified or provided by the manufacturer of this equipment could result in increased electromagnetic emissions or decreased electromagnetic immunity of this equipment and result in improper operation.

The AP17 access point ships with a mount bracket to mount the AP to a solid surface, such as a wall.

The following sections provide instructions on how to use the mount bracket.

1. Use the mount bracket as the template to mark the four mounting points on the wall.
2. Use a drill to make four holes on the four markings from the previous step.
3. Insert an anchor bolt (not included in the package) into each drilled hole.
4. Place the mount bracket over the anchor bolts and press the bracket against the wall.
5. Place the washers and nut onto the bolt's threaded end and tighten the nut until the mount bracket is firmly attached to the wall.

Figure 3 Attaching the Mount Bracket to a Wall

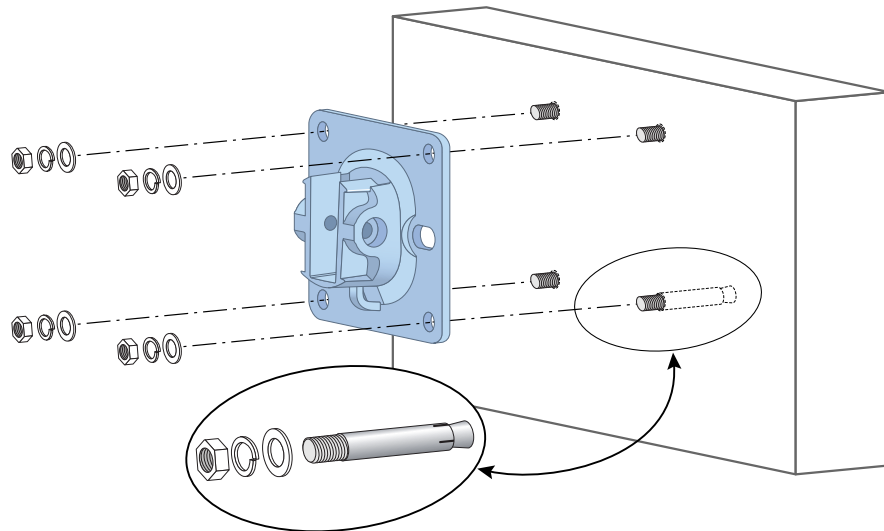

6. Slide the holder of the AP into the opening of the mount bracket and use the M6x45 screw included in the package to fix the AP to the mount bracket.

Figure 4 Attaching the AP to the Mount Bracket

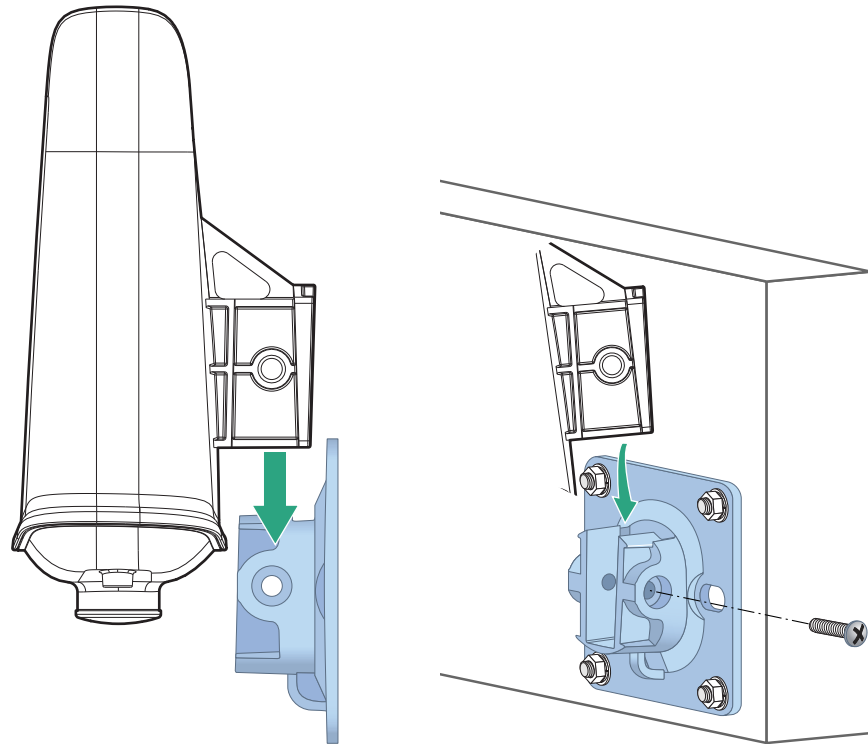
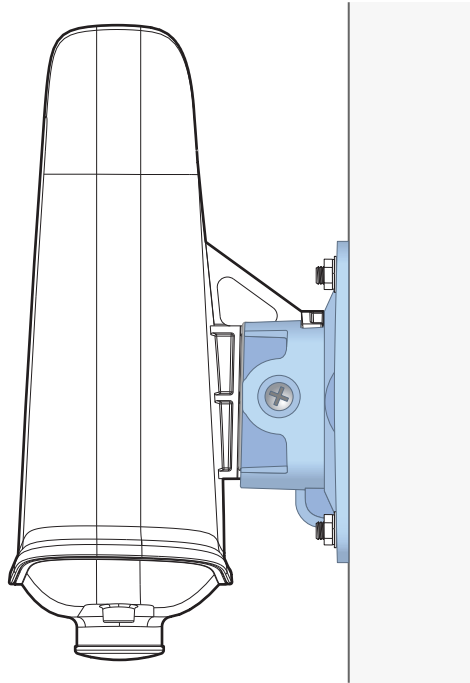

Figure 5 *Attaching the AP to the Mount Bracket (Completed)*



Grounding the AP

The grounding must be completed before powering up the access point. The grounding wire should be #8 AWG.

1. Peel the cover of one end of the grounding wire and place the bare grounding wire into the included copper lug, and press firmly with the crimping pliers.
2. Fasten the copper lug to the grounding hole on the AP with the included M4 x6 screw.

Powering the AP

To power the AP17 access point, connect an outdoor rated Cat5e or above Ethernet cable from the Ethernet port of the AP17 to a PoE port of a 802.3af compliant PoE Injector.

The PoE injector will be installed indoors and then a long cable will have to run from inside to outside where the AP is located. This cable will then be powering the AP. The PoE injector is not meant for outdoor installation as it is not weather tolerant.

When connecting the Ethernet cable to the Ethernet port of the AP17, the included cable gland must be installed to seal the connection.

Perform the following steps:

1. Slide the sealing nut over the cable (without the RJ45 connector attached to the end).
2. Slide the gland body over the cable.
3. Using a crimping tool, attach the shielded RJ45 connector to the end of the cable.
4. Remove the weatherproof cap on the Ethernet port.
5. Insert the RJ45 connector to the Ethernet port.
6. Move the seals towards the gland body until it locates at the recess of the gland body.
7. Screw the sealing nut onto the gland body. The Ethernet cable is now completely connected to the Ethernet port of AP17
8. Connect the other end of the Ethernet cable to a PoE port of a 802.3af compliant PoE Injector or PoE switch.

Figure 6 Cable Gland Exploded View

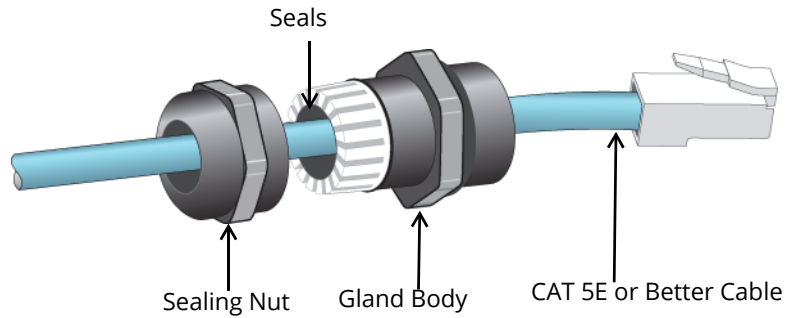

Failure to use the included Ethernet cable gland can lead to connectivity and POE issues.



Outdoor rated Cat5e or above cable should be used for all outdoor wired Ethernet connections and should be grounded through the AC ground of the PoE.



Cable feed must be pointed downwards when wall-mounted.



The seals inside the clamping ring by factory default is applicable for cables with 5-8.5 mm diameter. In the cable gland kit, another seals is provided for use with the cables with 7-10 mm diameter.

Verifying Post-Installation Connectivity

The integrated LED on the AP can be used to verify that the access point is receiving power and initializing successfully (see [Table 1](#) and [Table 2](#)).

Mobile Application Installation

Click the Apple App Store or Google Play badge below to download and install the Aruba Instant On mobile app to your phone. Launch the app and follow the instructions to complete the setup. Alternately, simply search for "Aruba Instant On" app within Apple App Store or Google Play.



Log in to Instant On Portal

Alternately, you can set up the Aruba Instant On access point from a web browser. Open a web browser and enter <https://portal.ArubaInstantOn.com> in the address bar to access the Aruba Instant On portal login screen. In the login screen, enter your Instant On account credentials to access your site.

Figure 7 Instant On Portal Login Screen



Log in to Instant On Portal

Enter your Instant On account credentials to access your site.

Email

Password

[Forgot your password?](#)

[Don't have an account? Create an account first.](#)

Electrical and Environmental Specifications

Electrical

- Ethernet:
 - One 10/100/1000 Base-T auto-sensing Ethernet interface (RJ-45)
- Power:
 - Maximum (worst-case) power consumption: 12.95W (802.3af PoE)
 - Power over Ethernet (PoE): 802.3af complaint source
 - Connect only to IEC 60950-1 or IEC 60601-1 3rd edition products and power sources.

Environmental

- Operating:
 - Temperature: -40° C to +50° C (-40° F to +122° F)
 - Humidity: 5% to 93% non-condensing
- Storage and transport
 - Temperature: -40° C to +70° C (-40° F to +158° F)

Regulatory Model Number

- AP17 RMN: APEX017

Safety and Regulatory Compliance



RF Radiation Exposure Statement: This equipment complies with RF radiation exposure limits. This equipment should be installed and operated with a minimum distance of 13.78 inches (35cm) between the radiator and your body for 2.4 GHz and 5 GHz operations. This transmitter must not be co-located or operating in conjunction with any other antenna or transmitter.



Déclaration de la concernant l'exposition aux rayonnements à fréquence radioélectrique (FR): Cet appareil est conforme aux limites d'exposition aux rayonnements FR établies. Il doit être installé et utilisé à une distance minimale de 35 cm (13,78 pouces) entre le radiateur et votre corps, qu'il opère sur la bande 2,4 GHz ou 5 GHz. Cet émetteur ne doit pas être installé ou utilisé à proximité immédiate d'une autre antenne ni d'un autre transmetteur.



Changes or modifications to this unit not expressly approved by the party responsible for compliance could void the user's authority to operate this equipment.



Toute modification effectuée sur cet équipement sans l'autorisation expresse de la partie responsable de la conformité est susceptible d'annuler son droit d'utilisation.

Federal Communication Commission

This device complies with Part 15 of the FCC Rules. Operation is subject to the following two conditions: (1) this device may not cause harmful interference, and (2) this device must accept any interference received, including interference that may cause undesired operation.

This equipment has been tested and found to comply with the limits for a Class B digital device, pursuant to Part 15 of the FCC Rules. These limits are designed to provide reasonable protection against harmful interference in a residential installation. This equipment generates, uses and can radiate radio frequency energy and, if not installed and used in accordance with the manufacturer's instructions, may cause harmful interference to radio communications. However, there is no guarantee that interference will not occur in a particular installation. If this equipment does cause harmful interference to radio or television reception, which can be determined by turning the equipment off and on, the user is encouraged to try to correct the interference by one or more of the following measures:

- Reorient or relocate the receiving antenna.
- Increase the separation between the equipment and receiver.
- Connect the equipment to an outlet on a circuit different from that to which the receiver is connected.
- Consult the dealer or an experienced radio or TV technician for help.

Industry Canada

This Class B digital apparatus meets all of the requirements of the Canadian Interference-Causing Equipment Regulations.

This device complies with Industry Canada's license-exempt RSS regulations. Operation of this device is subject to the following two conditions: (1) this device may not cause interference, and (2) this device must accept any interference, including interference that may cause undesired operation.

Déclaration d'Industrie Canada

Ce périphérique est conforme aux règlements RSS exempts de licence d'Industrie Canada. L'utilisation de ce périphérique est soumise aux deux conditions suivantes : (1) ce périphérique ne doit pas provoquer d'interférences, et (2) ce périphérique doit accepter toute interférence, y compris les interférences susceptibles de provoquer un dysfonctionnement.

Professional Installation Instruction

This product is designed for specific application and needs to be installed by a qualified personal who has RF and related rule knowledge. The general user shall not attempt to install or change the setting.

Please carefully select the installation position and make sure that the final output power does not exceed the limit set force in relevant rules. The violation of the rule could lead to serious federal penalty.

Instructions d'installation professionnelle

Ce produit est destiné à un usage spécifique et doit être installé par un personnel qualifié maîtrisant les radiofréquences et les règles s'y rapportant. L'installation et les réglages ne doivent pas être modifiés par l'utilisateur final.

Choisir avec soin la position d'installation et s'assurer que la puissance de sortie ne dépasse pas les limites en vigueur. La violation de cette règle peut conduire à de sérieuses pénalités fédérales.

European Union Regulatory Conformance

The Declaration of Conformity made under Radio Equipment Directive 2014/53/EU is available for viewing at: www.hpe.com/eu/certificates. Select the document that corresponds to your device's model number as it is indicated on the product label.

Wireless Channel Restrictions

5150-5350MHz band is limited to indoor only in the following countries; Austria (AT), Belgium (BE), Bulgaria (BG), Croatia (HR), Cyprus (CY), Czech Republic (CZ), Denmark (DK), Estonia (EE), Finland (FI), France (FR), Germany (DE), Greece (GR), Hungary (HU), Iceland (IS), Ireland (IE), Italy (IT), Latvia (LV), Liechtenstein (LI), Lithuania (LT),

Luxembourg (LU), Malta (MT), Netherlands (NL), Norway (NO), Poland (PL), Portugal (PT), Romania (RO), Slovakia (SK), Slovenia (SL), Spain (ES), Sweden (SE), Switzerland (CH), Turkey (TR), United Kingdom (UK).

Frequency Range MHz	Max EIRP
2402-2480	9 dBm
2412-2472	20 dBm
5150-5250	23 dBm
5250-5350	23 dBm
5470-5725	30 dBm
5725-5850	14 dBm

Medical

1. Equipment not suitable for use in the presence of flammable mixtures.
2. Connect to only IEC 60950-1 or IEC 60601-1 3rd edition certified products and power sources. The end user is responsible for the resulting medical system complies with the requirements of IEC 60601-1 3rd edition.
3. Wipe with a dry cloth, no additional maintenance required.
4. No serviceable parts, the unit must be sent back to the manufacturer for repair.
5. No modifications are allowed without Aruba approval.



This device is intended for indoor use in professional healthcare facilities.



This device has no IEC/EN60601-1-2 essential performance.



Use of this equipment adjacent to or stacked with other equipment should be avoided because it could result in improper operation. If such use is necessary, this equipment and the other equipment should be observed to verify that they are operating normally.



Compliance is based on the use of Aruba approved accessories.



Use of accessories, transducers and cables other than those specified or provided by the manufacturer of this equipment could result in increased electromagnetic emissions or decreased electromagnetic immunity of this equipment and result in improper operation.

Brazil



Este equipamento não tem direito à proteção contra interferência prejudicial e não pode causar interferência em sistemas devidamente autorizados.

Japan

ご使用になっている装置に VCCI マークが付いていましたら、次の説明文をお読み下さい。

この装置は、クラス B 情報技術装置です。この装置は、家庭環境で使用することを目的としていますが、この装置がラジオやテレビジョン受信機に近接して使用されると、受信障害を引き起こすことがあります。取扱説明書に従って正しい取り扱いをして下さい。

VCCI-B

México

La operación de este equipo está sujeta a las siguientes dos condiciones: (1) es posible que este equipo o dispositivo no cause interferencia perjudicial y (2) este equipo o dispositivo debe aceptar cualquier interferencia, incluyendo la que pueda causar su operación no deseada.

Morocco



Нормативные требования Евразийского Экономического Союза

Russia



НРЕ Russia: ООО "Хьюлетт Паккард Энтерпрайз" Российская Федерация, 125171, г. Москва, Ленинградское шоссе, 16А, стр.3, Телефон: +7 499 403 4248 Факс: +7 499 403 4677

'НРЕ Kazakhstan': ТОО «Хьюлетт-Паккард (К)», Республика Казахстан, 050040, г. Алматы, Бостандыкский район, проспект Аль-Фараби, 77/7, Телефон/факс: + 7 727 355 35 50

Kazakhstan

ЖШС "Хьюлетт Паккард Энтерпрайз" Ресей Федерациясы, 125171, Мәскеу, Ленинград тас жолы, 16А блок 3, Телефон: +7 499 403 4248 Факс: +7 499 403 4677

ЖШС «Хьюлетт-Паккард (К)», Қазақстан Республикасы, 050040, Алматы к., Бостандық ауданы, Әл-Фараби даңғылы, 77/7, Телефон/факс: +7 (727) 355 35 50

Taiwan

第十二條

經型式認證合格之低功率射頻電機，非經許可，公司、商號或使用者均不得擅自變更頻率、加大功率或變更原設計之特性及功能。

第十四條

低功率射頻電機之使用不得影響飛航安全及干擾合法通信；經發現有干擾現象時，應立即停用，並改善至無干擾時方得繼續使用。

前項合法通信，指依電信法規定作業之無線電通信。

低功率射頻電機須忍受合法通信或工業、科學及醫療用電波輻射性電機設備之干擾。

1. 本器材須經專業工程人員安裝及設定，始得設置使用，且不得直接販售給一般消費者。
2. 無線資訊傳輸設備避免影響附近雷達系統之操作。

Ukraine

Hereby, Hewlett Packard Enterprise Company declares that the radio equipment type APIN0303 is in compliance with Ukrainian Technical Regulation on Radio Equipment, approved by resolution of the CABINET OF MINISTERS OF UKRAINE dated May 24, 2017, No. 355. The full text of the UA declaration of conformity is available at the following internet address: <https://certificates.ext.hpe.com/public/certificates.html>

Hong Kong



Philippines



Singapore

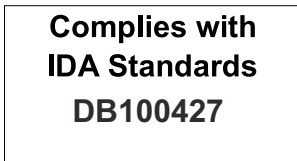

Contact Aruba

Main Site	https://www.ArubaInstantOn.com
Support Site	https://support.ArubaInstantOn.com
Aruba Instant On Community	https://community.ArubaInstantOn.com
North America Telephone	1-800-943-4526 1-408-754-1200
International Telephone	https://support.ArubaInstantOn.com

Copyright

© Copyright 2019 Hewlett Packard Enterprise Development LP

Open Source Code

This product includes code licensed under the GNU General Public License, the GNU Lesser General Public License, and/or certain other open source licenses. A complete machine-readable copy of the source code corresponding to such code is available upon request. This offer is valid to anyone in receipt of this information and shall expire three years following the date of the final distribution of this product version by Hewlett Packard Enterprise Company. To obtain such source code, send a check or money order in the amount of US \$10.00 to:

Hewlett Packard Enterprise Company
Attn: General Counsel
6280 America Center Drive
San Jose, CA 95002
USA

Warranty

This hardware product is protected by an Aruba warranty. For details, visit <https://www.ArubaInstantOn.com/docs>.