



# Maximal FV Series

## Dual Power Supply

### Access Power Controllers (fused)

### Models Include:

#### Maximal11FDV

- Power Supply 1:  
12VDC @ 3.3A or 24VDC @ 3.6A.
- Power Supply 2:  
12VDC @ 3.3A or 24VDC @ 3.6A.
- Sixteen (16) PTC protected outputs.

#### Maximal33FDV

- Power Supply 1:  
12VDC @ 5.3A or 24VDC @ 5.6A.
- Power Supply 2:  
12VDC @ 5.3A or 24VDC @ 5.6A.
- Sixteen (16) PTC protected outputs.

#### Maximal55FDV

- Power Supply 1: 12VDC @ 9.3A.
- Power Supply 2: 12VDC @ 9.3A.
- Sixteen (16) PTC protected outputs.

#### Maximal75FDV

- Power Supply 1: 12VDC @ 9.3A.
- Power Supply 2: 24VDC @ 9.6A.
- Sixteen (16) PTC protected outputs.

#### Maximal77FDV

- Power Supply 1: 24VDC @ 9.6A.
- Power Supply 2: 24VDC @ 9.6A.
- Sixteen (16) PTC protected outputs.

## Installation Guide



Rev. MFFDV031115

More than just power.™

Installing Company: \_\_\_\_\_ Service Rep. Name: \_\_\_\_\_

Address: \_\_\_\_\_ Phone #: \_\_\_\_\_

# Table of Contents:

MaximalFDV Series Overview . . . . .	pg. 3
MaximalFDV Series Configuration Chart . . . . .	pg. 3
Maximal Series Features. . . . .	pg. 4
ACM8CB Access Power Controller Modules . . . . .	pg. 4
eFlow Power Supply/Charger . . . . .	pg. 4
MaximalFDV Installation Instructions . . . . .	pg. 5
Maintenance . . . . .	pg. 6
Power Supply Board LED Diagnostics . . . . .	pg. 7
Access Power Controller LED Diagnostics . . . . .	pg. 7
Power Supply Board Terminal Identification . . . . .	pg. 7
Access Power Controller Terminal Identification . . . . .	pg. 8
Power Supply Board Stand-by Battery Specifications . . . . .	pg. 8
Power Supply Board Output Voltage Settings. . . . .	pg. 9
Access Power Controller Typical Application Diagram (for each ACM8CB) . . . . .	pg. 9
MaximalFDV Battery Hookup and Tamper Switch Installation . . . . .	pg. 10
NEC Power-Limited Wiring Requirements . . . . .	pg. 11
FACP/Optional Power Supply Hook-Up Diagrams . . . . .	pg. 12
Enclosure Dimensions . . . . .	pg. 15

## MaximalFDV Series Overview:

Altronix MaximalFDV Access Power/Controllers distribute and switch power to access control systems and accessories. They convert a 220VAC (working range 198VAC - 256VAC), 50/60Hz input into sixteen (16) independently controlled 12VDC or 24VDC PTC protected outputs. Outputs are activated by an open collector sink or normally open (NO) dry trigger input from an Access Control System, Card Reader, Keypad, Push Button, PIR, etc. Units will route power to a variety of access control hardware devices including: Mag Locks, Electric Strikes, Magnetic Door Holders, etc. Outputs will operate in both Fail-Safe and/or Fail-Secure modes. The FACP Interface enables Emergency Egress, Alarm Monitoring, or may be used to trigger other auxiliary devices. The fire alarm disconnect feature is individually selectable for any or all of the eight (8) outputs.

### MaximalFDV Series Configuration Chart:

Altronix Model Number	Nominal DC Output Voltage Options								Maximum Supply Current for Main and Aux. Outputs (Power Supply 1 / Power Supply 2) (A)	PTC Protected Auto-Resettable Outputs	220VAC 50/60 Hz Input (current)	Current per ACM8CB output (A)	Power Supply Board Input Fuse Rating	Power Supply Board Battery Fuse Rating
	Power Supply 1				Power Supply 2									
	[DC]		[AUX]		[DC]		[AUX]							
12VDC Output Range (V)	24VDC Output Range (V)	12VDC Output Range (V)	24VDC Output Range (V)	12VDC Output Range (V)	24VDC Output Range (V)	12VDC Output Range (V)	24VDC Output Range (V)							
Maximal11FDV	eFlow4NBV				eFlow4NBV				-	16	4.2A	2.5	5A/250V	7.5A/32V
	9.8-13.2	-	10.05-13.2	-	9.8-13.2	-	10.05-13.2	-	3.3A + 3.3A					
	9.8-13.2	-	10.05-13.2	-	19.9-26.4	-	20.2-26.4	-	3.3A + 3.6A					
	-	19.9-26.4	-	20.2-26.4	-	19.9-26.4	-	20.2-26.4	3.6A + 3.6A					
Maximal33FDV	eFlow6NBV				eFlow6NBV				-	16	4.2A	2.5	5A/250V	10A/32V
	9.7-13.2	-	10.03-13.2	-	9.7-13.2	-	10.03-13.2	-	5.3A + 5.3A					
	9.7-13.2	-	10.03-13.2	-	19.8-26.4	-	20.19-26.4	-	5.3A + 5.6A					
	-	19.8-26.4	-	20.19-26.4	-	19.8-26.4	-	20.19-26.4	5.6A + 5.6A					
Maximal55FDV	eFlow102NBV				eFlow102NBV				-	16	4.2A	2.5	5A/250V	15A/32V
	9.7-13.2	-	10.03-13.2	-	9.7-13.2	-	10.03-13.2	-	9.3A + 9.3A					
Maximal75FDV	eFlow102NBV				eFlow104NBV				9.3A + 9.6A	16	4.8A	2.5	5A/250V (eFlow102NBV) 6.3A/250V (eFlow104NBV)	15A/32V
	9.7-13.2	-	10.03-13.2	-	-	19.8-26.4	-	20.28-26.4						
Maximal77FDV	eFlow104NBV				eFlow104NBV				9.6A + 9.6A	16	5.4A	2.5	6.3A/250V	15A/32V
	-	19.8-26.4	-	20.28-26.4	-	19.8-26.4	-	20.28-26.4						

**All units:** These unit are suitable to power: sensors, electro-mechanical devices (e.g. electric door strikes).

## MaximalFDV Series Features:

### ACM8CB Access Power Controller Modules:

- Sixteen (16) independently trigger controlled outputs. Output options:
  - a) Sixteen (16) Fail-Safe filtered power outputs.
  - b) Sixteen (16) Fail-Secure filtered power outputs.
  - c) Any combination of the above.
- Sixteen (16) Access Control System trigger inputs. Input trigger options:
  - a) Sixteen (16) normally open (NO) dry trigger inputs.
  - b) Sixteen (16) open collector inputs.
  - c) Any combination of the above.
- Sixteen (16) unswitched filtered aux. power outputs (outputs are rated @ 2.5A).
- Red LEDs on ACM8CB board indicate individual outputs are triggered (relays energized).
- Fire Alarm disconnect (latching or non-latching) is individually selectable for any or all of the sixteen (16) outputs.

Fire Alarm disconnect input trigger options:

  - a) Normally open (NO) or normally closed (NC) dry trigger input.
  - b) Polarity reversal input from FACP signaling circuit.
- Green LED on ACM8CB board indicates FACP disconnect is triggered.
- FACP output relay indicates that FACP input is triggered.
- eFlow Power Supply/Charger provides common power for ACM8CB board (factory wiring) and all connected access control devices (field wiring).
- ACM8CB board main fuses are rated @ 10A. Output PTCs are rated @ 2.5A.

### eFlow Power Supply/Charger:

- Input: 220VAC, 50/60Hz.
  - For output voltage and supply current refer to *MaximalFDV series Configuration Chart, pg. 3*.
  - Auxiliary output rated @ 1A (unswitched).
  - Overvoltage protection.
  - Built-in charger for sealed lead acid or gel type batteries.
  - Maximum charge current 1.54A.
  - Automatic switch over to stand-by battery when AC fails. Transfer to stand-by battery power is instantaneous with no interruption.
  - Supervised Fire Alarm disconnect (latching or non-latching) 10K EOL resistor. Operates on a normally open (NO) or normally closed (NC) trigger.
  - AC fail supervision (form "C" contacts).
  - Battery fail & presence supervision (form "C" contacts).
  - Low power shutdown. Shuts down DC output terminals if battery voltage drops below 71-73% for 12V units and 70-75% for 24V units (depending on the power supply). Prevents deep battery discharge.
  - For fuse ratings refer to *MaximalFDV series Configuration Chart, pg. 3*.
  - Green AC Power LED indicates 220VAC present.
  - AC input and DC output LED indicators.
  - Short circuit and overload protection.
  - Enclosure accommodates up to four (4) 12VDC/12AH batteries.
- Enclosure dimensions (H x W x D): 26" x 19" x 6.25" (660.4mm x 482.6mm x 158.8mm).

## MaximalFDV Installation Instructions:

Wiring methods shall be in accordance with the National Electrical Code/NFPA 70/ANSI, the Canadian Electric Code, Part I, Part II and with all local codes and authorities having jurisdiction. Product is intended for indoor use only.

Power Supply Board LED Diagnostics	(pg. 7)
Access Power Controller LED Diagnostics	(pg. 7)
Power Supply Board Terminal Identification	(pg. 7)
Access Power Controller Terminal Identification	(pg. 8)
Power Supply Board Stand-by Battery Specifications	(pg. 8)
Power Supply Board Output Voltage Settings	(pg. 9)
Access Power Controller Typical Application Diagram	(pg. 9)
FACP/Optional Power Supply Hook-up Diagrams	(pg. 12)

1. Mount unit in desired location. Mark and predrill holes in the wall to line up with the top three keyholes in the enclosure. Install three upper fasteners and screws in the wall with the screw heads protruding. Place the enclosure's upper keyholes over the three upper screws, level and secure. Mark the position of the lower three holes. Remove the enclosure. Drill the lower holes and install the three fasteners. Place the enclosure's upper keyholes over the three upper screws. Install the three lower screws and make sure to tighten all screws (*Enclosure Dimensions, pg. 15*).

2. Connect unswitched AC power (220VAC 50/60Hz) to terminals marked [L, N] (*Fig. 3, pg. 10*). Use 14 AWG or larger for all power connections. Secure green wire lead to earth ground lug.

**Keep power-limited wiring separate from non power-limited wiring.**

**Minimum 0.25" spacing must be provided (Fig. 3, pg. 10).**

**CAUTION: Do not touch exposed metal parts. Shut branch circuit power before installing or servicing equipment. There are no user serviceable parts inside. Refer installation and servicing to qualified service personnel.**

3. Select desired DC output voltage by setting SW1 to the appropriate position on the power supply board on Maximal11FDV and Maximal33FDV, (*Fig. 1, pg. 9*). Maximal55FDV power supply is factory set at 12VDC. Maximal77FDV power supply is factory set at 24VDC. Maximal75FDV consists of one (1) power supply board that is factory set at 12VDC, and one (1) power supply board that is factory set at 24VDC.
4. Measure the output voltage of the unit before connecting any devices to ensure proper operation. Improper or high voltage will damage these devices.

5. **Output options** (*Fig. 2, pg. 9*):

The unit will provide either sixteen (16) switched power outputs, sixteen (16) dry form "C" outputs, or any combination of both switched power and form "C" outputs.

**(a) Fail-Safe Switched Power outputs:**

For Fail-Safe operation connect the positive (+) input of the access control devices to terminal marked [NC]. Connect the negative (-) input of the access control devices to terminal marked [COM].

**(b) Fail-Secure Switched Power outputs:**

For Fail-Secure operation connect the positive (+) input of the access control devices to terminal marked [NO]. Connect the negative (-) input of the access control devices to terminal marked [COM].

6. **ACM8CB Auxiliary Power outputs (unswitched):**

Connect access control devices that require constant power to terminals marked [C] positive (+) and [COM] negative (-).

**eFlow Auxiliary outputs (unswitched):**

For auxiliary device connection this output will not be affected by Low Power Disconnect or Fire Alarm Interface. Connect device to terminals marked [+ AUX -] (*Fig. 3, pg. 10*).

7. **Input trigger options** (*Fig. 2, pg. 9*):

**(a) Normally Open [NO] input trigger:**

Inputs 1-8 are activated by normally open or open collector sink inputs. Connect access control panel outputs, keypads, push buttons, REX PIRs, etc. to terminals marked [IN] and [GND].

**(b) Open Collector Sink inputs:**

Connect the access control panel open collector sink positive (+) to terminals marked [IN] and the negative (-) to terminals marked [GND].

8. **ACM8CB Fire Alarm Interface options** (Figs. 5-9, pg. 12):  
 A normally closed [NC] or normally open [NO] input trigger from a fire alarm control panel or a polarity reversal input from an FACP signaling circuit will affect selected outputs. To enable FACP Disconnect for an output turn the corresponding switch(es) [SW1-SW8] OFF on each ACM8CB board. To disable FACP disconnect for an output turn the corresponding switch(es) [SW1-SW8] ON on each ACM8CB board.
  - (a) **Normally Open [NO] input:**  
 For non-latching hook-up refer to Fig. 6, pg. 12. For latching hook-up refer to Fig. 7, pg. 12.
  - (b) **Normally Closed [NC] input:**  
 For non-latching hook-up refer to Fig. 8, pg. 12. For latching hook-up refer to Fig. 9, pg. 12.
  - (c) **FACP Signaling Circuit input trigger:**  
 Connect the positive (+) and negative (-) from the FACP signaling circuit output to the terminals marked [+ INP -]. Connect the FACP EOL to the terminals marked [+ RET -] (polarity is referenced in an alarm condition). Jumper located next to TRG LED must be cut (Fig. 2a, pg. 9 and Fig. 6, pg. 12).
9. **FACP Dry form "C" output** (not evaluated by UL) (Fig. 2b, pg. 9):  
 FACP form "C" contacts can be use to trigger reporting or signaling devices. These contacts switch upon a fire alarm input trigger to the ACM8CB boards.
10. **Stand-by Battery Connections** (Fig. 3, pg. 10):  
 For U.S. Access Control applications batteries are optional. Batteries are required for Canadian installations (ULC-S319). When batteries are not used, a loss of AC will result in the loss of output voltage. When the use of stand-by batteries is desired, they must be lead acid or gel type. Connect battery to terminals marked [- BAT +] (Fig. 3, pg. 10). Use two (2) 12VDC batteries connected in series for 24VDC operation (battery leads included). Use batteries - Casil CL1270 (12V/7AH), CL12120 (12V/12AH), CL12400 (12V/40AH), CL12650 (12V/65AH) batteries or UL recognized BAZR2 and BAZR8 batteries of an appropriate rating.
11. **Battery and AC Supervision outputs** (Fig. 3, pg. 10):  
 It is required to connect supervisory trouble reporting devices to outputs marked [AC Fail, BAT Fail] supervisory relay outputs marked [NC, C, NO] to appropriate visual notification devices. Use 22 AWG to 18 AWG for AC Fail and Low/No Battery reporting.
12. To delay AC reporting for 2 hrs., set DIP switch [AC Delay] to OFF position (Fig. 3, pg. 10).  
 To delay AC reporting for 1 min., set DIP switch [AC Delay] to ON position (Fig. 3, pg. 10).
13. **Low Power Shutdown** (Fig. 3, pg. 10):  
 To enable Low Output Power Shutdown, set DIP switch [Shutdown] to ON position.  
 To disable Low Output Power Shutdown, set DIP switch [Shutdown] to OFF position.
14. **Installation of tamper switch (Not Included)** (Fig. 3a, pg. 10):  
 Mount UL Listed tamper switch (Honeywell model 112 or equivalent) at the top of the enclosure. Slide the tamper switch bracket onto the edge of the enclosure approximately 2" from the right side (Fig. 3a, pg. 10). Connect tamper switch wiring to the Access Control Panel input or the appropriate UL Listed reporting device. To activate alarm signal, open the door of the enclosure.
15. **Multiple power supply inputs** (Fig. 2, pg. 9):  
 When using an additional Listed external power supply, jumpers J1 and J2 located on corresponding ACM8CB board must be cut (Fig. 2c, pg. 9 and Fig. 5, pg. 12). Connect external Listed power-limited access control power supply to the terminals marked [- Control +] (These terminals are paralleled to the [- Power +] terminals). When using DC power supplies, polarity must be observed. When using AC power supplies, polarity needs not be observed (Fig. 2d, pg. 9). All field wiring connections must be made employing suitable gauge CM or FPL jacketed wire (or equivalent substitute) (Fig. 4a, pg. 11).

## Maintenance:

Unit should be tested at least once a year for the proper operation as follows:

- FACP Supervision:** To ensure proper connection and operation of the Fire Alarm disconnect hookup. Please follow the appropriate procedure below:
- Normally Open Input:** Placing a short between terminals marked [T] and [+ INP] will trigger the Fire Alarm Disconnect. Remove the short to reset.
- Normally Closed Input:** Removing the wire from terminal marked [INP -] will trigger the Fire Alarm Disconnect. Replace the wire to terminal marked [INP -] to reset.
- FACP Signal Circuit Input:** It is necessary to trigger the Fire Alarm System. In all of the above scenarios the green TRG LED of the ACM8CBs will illuminate. All outputs selected for Fire Alarm Disconnect will activate releasing locking devices.
- Note:** All outputs [OUT 1] - [OUT 8] must be in a normal (de-energized) condition prior to testing. When the unit is configured for Normally Open (Fig. 8, pg. 12) or Normally Closed (Fig. 10, pg. 12) latching operation, it is necessary to reset the Fire Alarm Disconnect by activating the Normally Closed reset switch.
- Output Voltage Test:** Under normal load conditions, the DC output voltage should be checked for proper voltage level (refer to MaximalFDV series Configuration Chart, pg. 3).
- Battery Test:** Under normal load conditions check that the battery is fully charged, check specified voltage at the battery terminals and at the board terminals marked [+ BAT -] to ensure that there is no break in the battery connection wires.
- Note:** Maximum charge current is 1.54A. Expected battery life is 5 years; however, it is recommended to change batteries within 4 years or less if necessary.

### Power Supply Board LED Diagnostics:

Red (DC)	Green (AC/AC1)	Power Supply Status
ON	ON	Normal operating condition.
ON	OFF	Loss of AC. Stand-by battery is supplying power.
OFF	ON	No DC output.
OFF	OFF	Loss of AC. Discharged or no stand-by battery. No DC output.

Red (Bat)	Battery Status
ON	Normal operating condition.
OFF	Battery fail/low battery.

### Access Power Controller LED Diagnostics:

LED	ON	OFF
LED 1- LED 8 (Red)	Output relay(s) energized.	Output relay(s) de-energized.
Trg (Green)	FACP input triggered (alarm condition).	FACP normal (non-alarm condition).

### Power Supply Board Stand-by Battery Specifications:

Battery	Maximal11FDV	Maximal33FDV	Maximal55FDV, Maximal75FDV and Maximal77FDV
7AH	30 Mins./4A	10 Mins./6A	5 Mins./10A
12AH	35 Mins./4A	30 Mins./6A	30 Mins./10A
40AH	Over 4 Hours/4A	Over 4 Hours/6A	Over 2 Hours/10A
65AH	Over 4 Hours/4A	Over 4 Hours/6A	Over 4 Hours/10A

\*Only these configurations can be utilized in Canadian installations.

## Power Supply Board Terminal Identification:

Terminal Legend	Function/Description
L, N	Connect 220VAC, 50/60Hz to these terminals: L to hot, N to neutral. Do not use terminal marked [G].
+ DC –	Factory connected to ACM8CB board.
Trigger EOL Supervised	Fire Alarm Interface trigger input from a short or FACP. Trigger inputs can be normally open, normally closed from an FACP output circuit ( <i>Fig. 3, pg. 10</i> ).
NO, GND RESET	FACP interface latching or non-latching ( <i>Fig. 3, pg. 10</i> ).
+ AUX –	Auxiliary Power-Limited output rated @ 1A (unswitched) ( <i>Fig. 3, pg. 10</i> ).
AC FAIL NC, C, NO	Indicates loss of AC power, e.g. connect to audible device or alarm panel. Relay normally energized when AC power is present. Contact rating 1A @ 30VDC ( <i>Fig. 3, pg. 10</i> ).
BAT FAIL NC, C, NO	Indicates low battery condition, e.g. connect to alarm panel. Relay normally energized when DC power is present. Contact rating 1A @ 30VDC. A removed battery is reported within 5 minutes. Battery reconnection is reported within 1 minute ( <i>Fig. 3, pg. 10</i> ).
+ BAT –	Stand-by battery connections. Maximum charge current 1.54A ( <i>Fig. 3, pg. 10</i> ).

## Access Power Controller Terminal Identification:

Terminal Legend	Function/Description
– Power +	12VDC or 24VDC from power supply/charger (factory connected). These terminals are paralleled to the [– Control +] terminals.
– Control +	These terminals are paralleled to the [– Power +] terminals. These terminals can be connected to an external Listed power-limited access control power supply to provide isolated operating power for the devices (Not evaluated by UL). Jumpers J1 and J2 must be removed.
TRIGGER INPUT 1- INPUT 8 IN, GND	From normally open and/or open collector sink trigger inputs (request to exit buttons, exit pir's, etc.)
OUTPUT 1- OUTPUT 8 NC, C, NO, COM	12VDC to 24VDC trigger controlled outputs. Maximum load per output is 2.5A.
	<b>Maximal11FDV:</b> P/S 1 - 9.8-13.2VDC @ 3.3A P/S 2 - 9.8-13.2VDC @ 3.3A or P/S 1 - 19.9-26.4VDC @ 3.6A P/S 2 - 19.9-26.4VDC @ 3.6A or P/S 1 - 9.8-13.2VDC @ 3.3A and P/S 2 - 19.9-26.4VDC @ 3.6A.
	<b>Maximal33FDV:</b> P/S 1 - 9.7-13.2VDC @ 5.3A P/S 2 - 9.7-13.2VDC @ 5.3A or P/S 1 - 19.8-26.4VDC @ 5.6A P/S 2 - 19.8-26.4VDC @ 5.6A or P/S 1 - 9.7-13.2VDC @ 5.3A and P/S 2 - 19.8-26.4VDC @ 5.6A.
	<b>Maximal55FDV:</b> P/S 1 - 9.7-13.2VDC @ 9.3A and P/S 2 - 9.7-13.2VDC @ 9.3A.
	<b>Maximal75FDV:</b> P/S 1 - 9.7-13.2VDC @ 9.3A and P/S 2 - 19.8-26.4VDC @ 9.6A.
	<b>Maximal77FDV:</b> P/S 1 - 19.8-26.4VDC @ 9.6A and P/S 2 - 19.8-26.4VDC @ 9.6A.
	Fail-Safe [NC positive (+) & COM Negative (–)], Fail-Secure [NO positive (+) & COM Negative (–)], Auxiliary output [C positive (+) & COM Negative (–)]. When using AC power supplies polarity needs not to be observed. Contacts shown in a non-triggered state.
FACP INTERFACE T, + INPUT –	Fire Alarm Interface trigger input from FACP. Trigger inputs can be normally open, normally closed from an FACP signaling circuit output ( <i>Figs. 5-9, pg. 12</i> ).
FACP INTERFACE NC, C, NO	Form “C” relay contact rated @ 1A 28VDC for alarm reporting.



# Power Supply Board Output Voltage Settings:

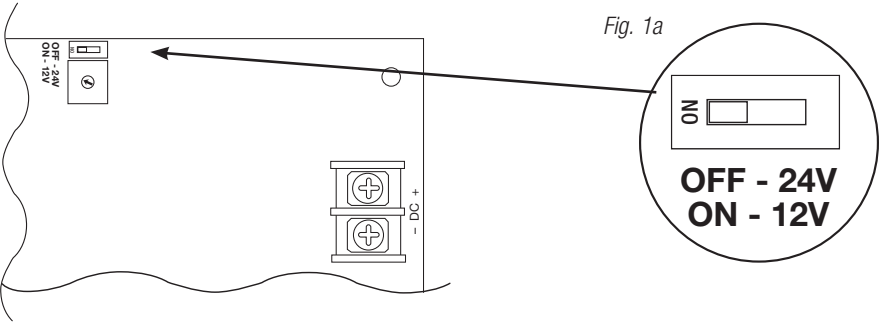

# Access Power Controller Typical Application Diagram (for each ACM8CB):

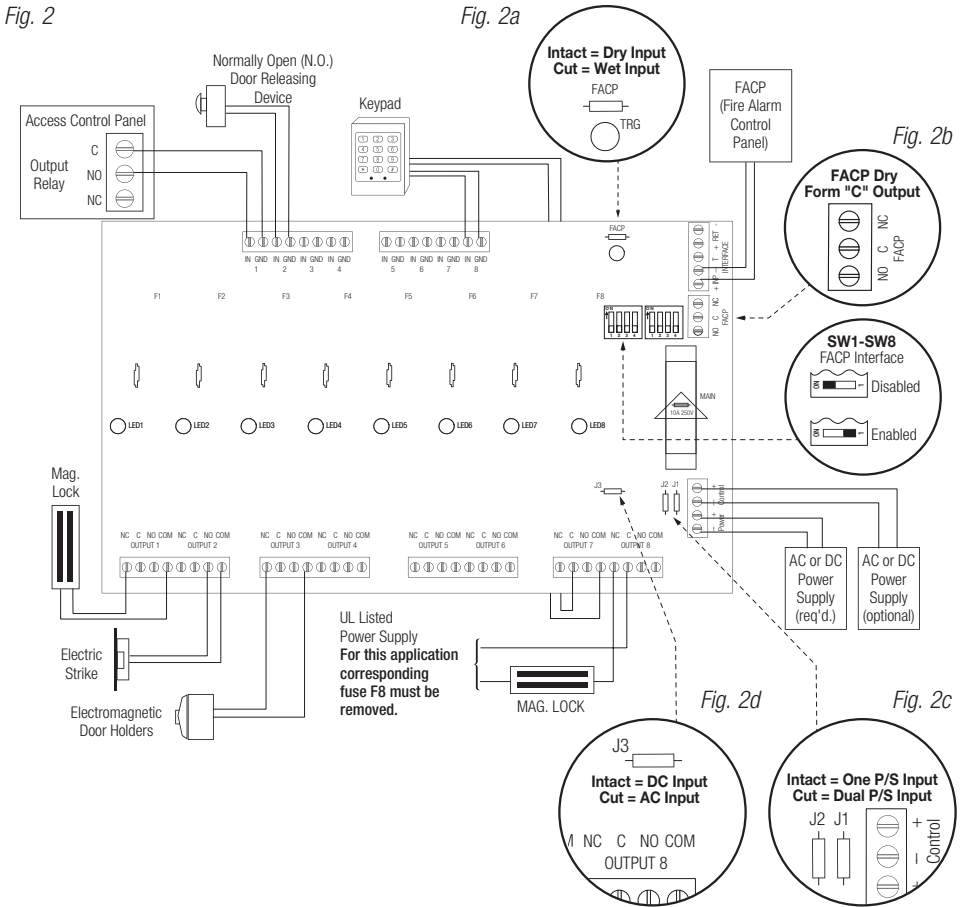
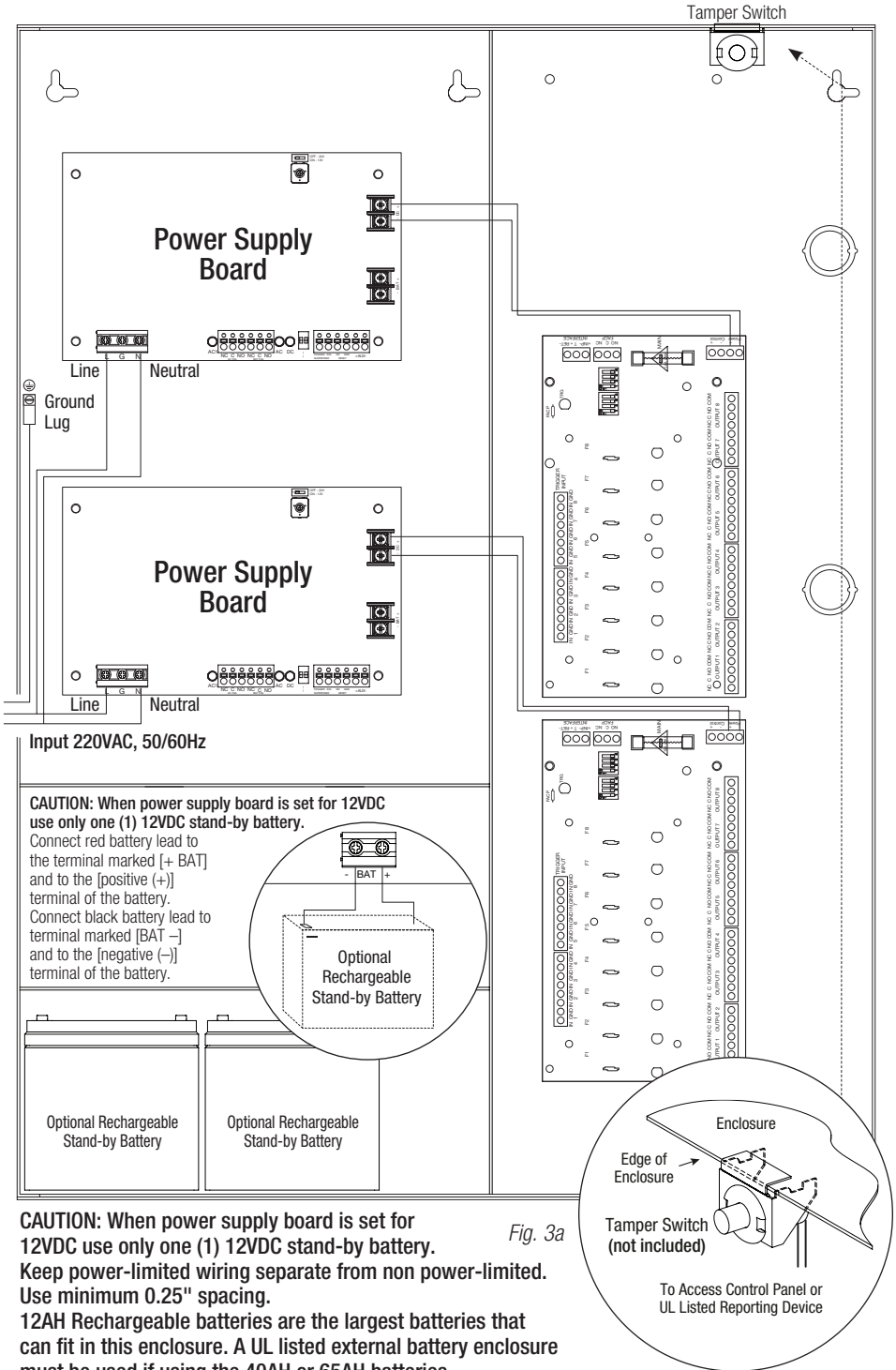

Fig. 3 - Maximal FDV Series



## NEC Power-Limited Wiring Requirements:

Power-limited and non power-limited circuit wiring must remain separated in the cabinet. All power-limited circuit wiring must remain at least 0.25" away from any non power-limited circuit wiring. Furthermore, all power-limited circuit wiring and non power-limited circuit wiring must enter and exit the cabinet through different conduits. One such example of this is shown below. Your specific application may require different conduit knockouts to be used. Any conduit knockouts may be used. For power-limited applications use of conduit is optional. All field wiring connections must be made employing suitable gauge CM or FPL jacketed wire (or equivalent substitute). Optional UL Listed battery enclosure must be mounted adjacent to the power supply via Class 1 wiring methods. For Canadian installations use shielded wiring for all connections. Note: Refer to wire handling drawing below for the proper way to install the CM or FPL jacketed wire (Fig. 4a).

Fig. 4

Supervisory Connections (power-limited)

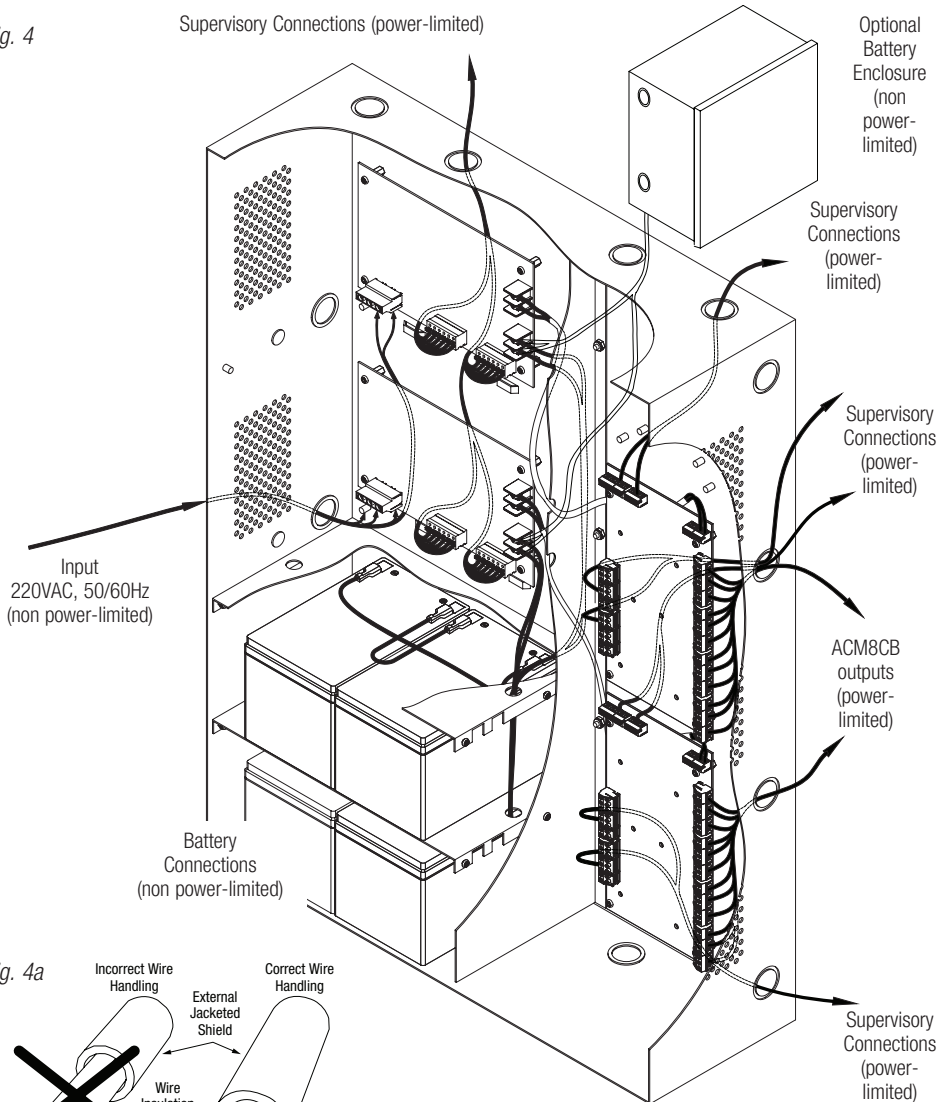
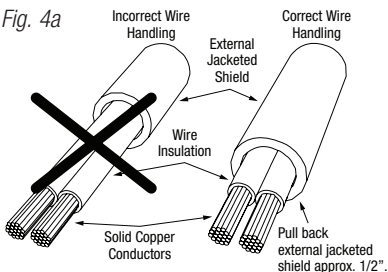

Fig. 4a



## FACP Hook-Up Diagrams:

Fig. 5 Optional hook-up using two (2) isolated power supply inputs (Only applicable on Maximal11FDV, not evaluated by UL):

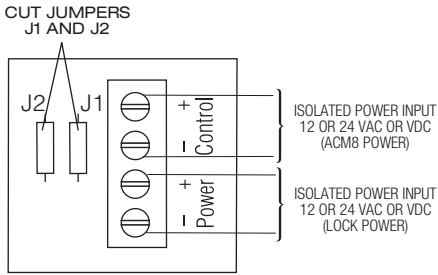

Fig. 6 Polarity reversal input from FACP signaling circuit output (polarity is referenced in alarm condition):

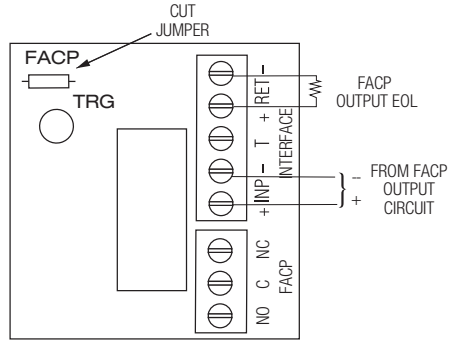

Fig. 7 Normally Open: Non-Latching FACP trigger input:

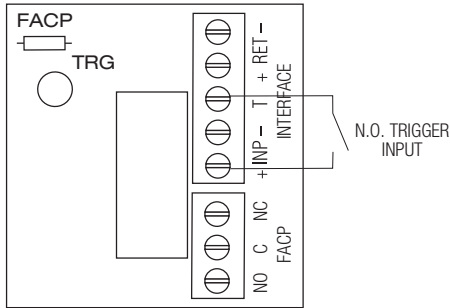

Fig. 8 Normally Open FACP Latching trigger input with reset (This output has not been evaluated by UL):

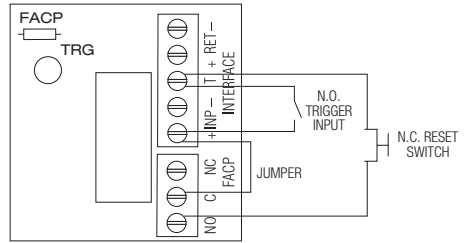

Fig. 9 Normally Closed: Non-Latching FACP trigger input:

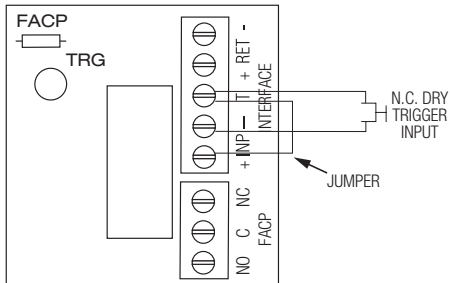
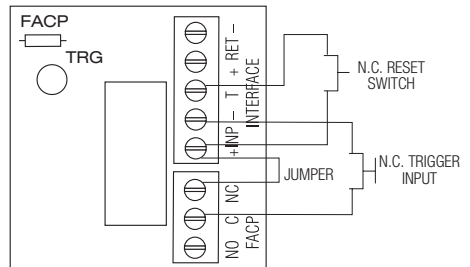

Fig. 10 Normally Closed: Latching FACP trigger input with reset (This output has not been evaluated by UL):



## Notes:

## Notes:

# Enclosure Dimensions (H x W x D approximate):

26" x 19" x 6.25" (660.4mm x 482.6mm x 158.8mm)

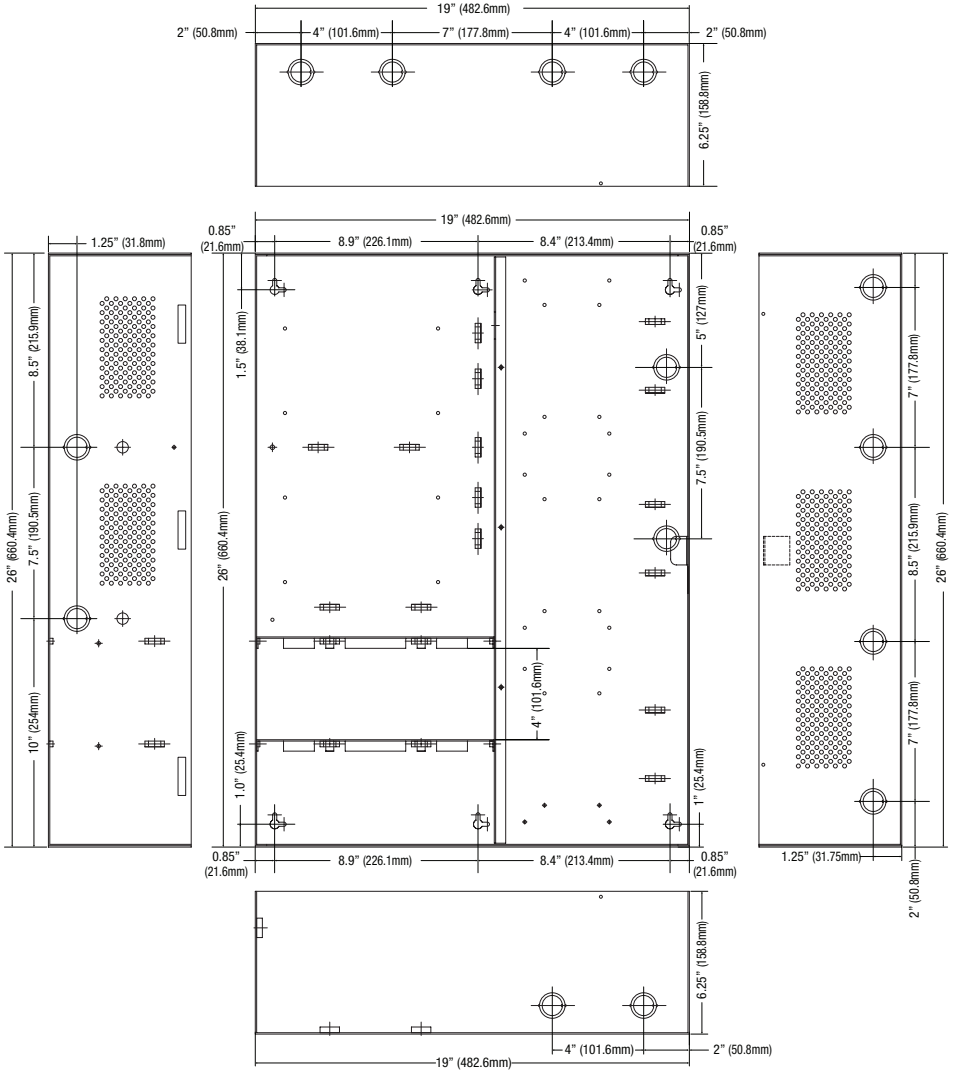

Altronix is not responsible for any typographical errors.

140 58th Street, Brooklyn, New York 11220 USA | phone: 718-567-8181 | fax: 718-567-9056  
 website: [www.altronix.com](http://www.altronix.com) | e-mail: [info@altronix.com](mailto:info@altronix.com) | Lifetime Warranty  
 IIMaximal11FDV/33FDV/55FDV/75FDV/77FDV Series H11U





## eFlow Power Supply/Chargers can be Controlled and Monitored while Reporting Power/Diagnostics from Anywhere over the Network...

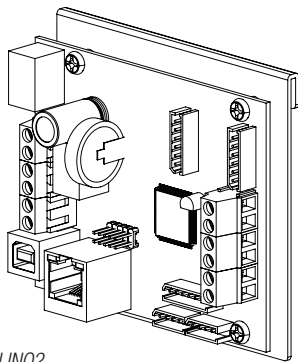

LINQ2

# LINQ™

### LINQ2 - Network Communication Module

LINQ2 provides remote IP access to real-time data from eFlow power supply/chargers to help keep systems up and running at optimal levels. It facilitates fast and easy installation and set-up, minimizes system downtime, and eliminates unnecessary service calls, which helps reduce Total Cost of Ownership (TCO) - as well as creating a new source of Recurring Monthly Revenue (RMR).

### Features:

- UL Listed in the U.S. and Canada.
- Local or remote control of up to (2) two Altronix eFlow power output(s) via LAN and/or WAN.
- Monitor real time diagnostics: DC output voltage, output current, AC & battery status/service, input trigger state change, output state change and unit temperature.
- Access control and user management: Restrict read/write, Restrict users to specific resources
- Two (2) integral network controlled Form "C" Relays.
- Three (3) programmable input triggers: Control relays and power supplies via external hardware sources.
- Email and Windows Dashboard notifications
- Event log tracks history.
- Secure Socket Layer (SSL).
- Programmable via USB or web browser - includes operating software and 6 ft. USB cable.

### LINQ2 Mounts Inside any Maximal F Enclosure

