



MLRK1-HAG

INSERT INSTRUCTIONS

The Command Access MLRK1 is a field installable motorized latch-retraction kit for:

- MRLK1-HAG - Hager 45/4600 series devices
- MRLK1-IDC - IDC 8000 series devices
- MRLK1-PDQ - PDQ 6200 series devices
- MRLK1-SQ - Stanley QED 1/2000 series devices
- MRLK1-LAW - Lawrence 8000 series devices
- MRLK1-LSDA1 - LSDA 9000 R/V series devices

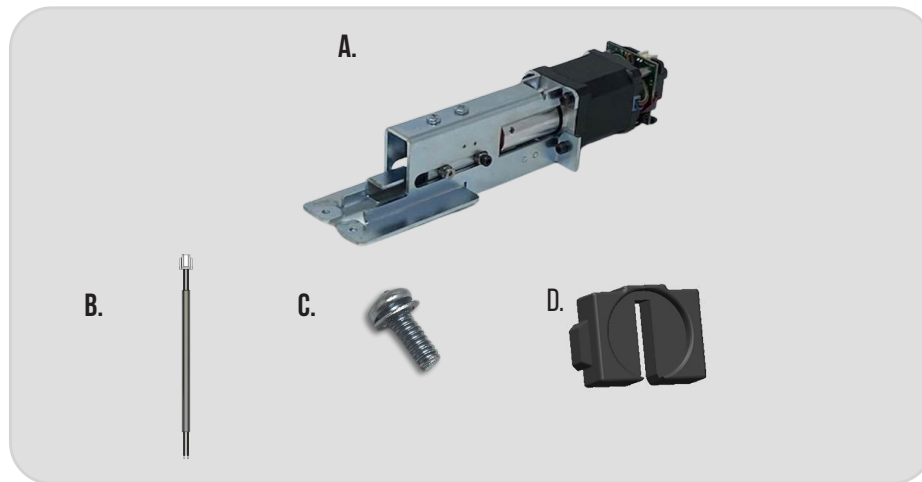

KIT INCLUDES

- A. 1- Motor Mount w/MM5
- B. 1- 50944 - Molex Pigtail
- C. 2- 40320 - M4 x 6MM Phillips Screws
- D. 1- 51235 Spacer

TOOLS REQUIRED

- Cordless Drill or Phillips Screwdriver

SPECIFICATIONS

- INPUT VOLTAGE: 24VDC +/- 10%
- AVERAGE LATCH RETRACTION CURRENT: 900 MA
- AVERAGE HOLDING CURRENT: 215 MA
- WIRE GAUGE: MINIMUM 18 GAUGE
- DIRECT WIRE RUN - NO RELAYS OR ACCESS CONTROL UNITS IN-BETWEEN POWER SUPPLY & MODULE

OPTIONAL BUILT-IN REX

- SPDT - RATED .5A @24V
- GREEN= COMMON (C)
- BLUE = NORMALLY OPEN (NO)
- GREY = NORMALLY CLOSED (NC)

RECOMMENDED POWER SUPPLIES: USE A POWER LIMITED CLASS 2 POWER SUPPLY

All Command Access exit devices & field installable kits have been thoroughly cycle tested with Command Access power supplies at our factory. If you plan on using a non-Command power supply it must be a filtered & regulated linear power supply.

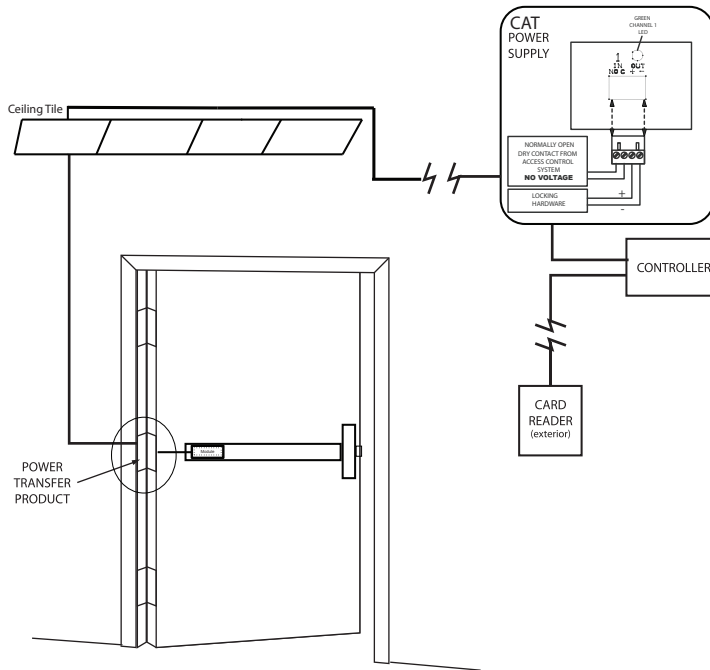

SETTING PUSH TO SET (PTS)

TO PUT THE DEVICE IN PTS MODE, FOLLOW THESE STEPS:

- Depress the MM5 button.
- Apply power and listen for short beep, which indicates that the device is now in PTS mode.
- Remove power.
- Release the button, but make sure you don't release it until the power is no longer going to the motor.

SET ADJUSTMENT:

- Depress the MM5 button.
- Depress the pushpad fully then release it 1/32", & hold.
- Apply power.
- Continue to hold the pushpad until the device gives you long beep.
- Remove power.

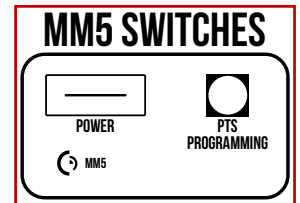

Note: Test the new location multiple times; if not to your liking, repeat the steps.

TROUBLESHOOTING & DIAGNOSTICS

BEEPS	EXPLANATION	SOLUTION
2 Beeps	Over Voltage	> 30V unit will shut down. Check voltage & adjust to 24 V.
3 Beeps	Under Voltage	< 20V unit will shut down. Check voltage & adjust to 24 V.
4 Beeps	Failed Sensor	Verify all 3 sensor wires are installed correctly. Replace sensor if problem persists by contacting office.
5 Beeps	Retraction or dogging failure	After 1st fail: 5 beeps then immediately attempts to retract again. After 2nd fail: 5 beeps with pause in-between for 30 seconds then device attempts to retract again. After 3rd fail: 5 beeps every 7 minutes, device will not attempt to retract. To Reset: Depress bar for 5 seconds at any time.

INSTALLATION INSTRUCTIONS

1. Remove **Head Cover** from device.



2. Remove (2) **Screws** securing Housing to Baserail.

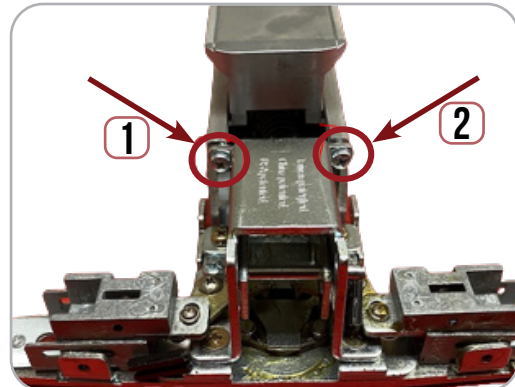

3. **Slide off** Housing to expose Pushpad & Baserail Assembly.

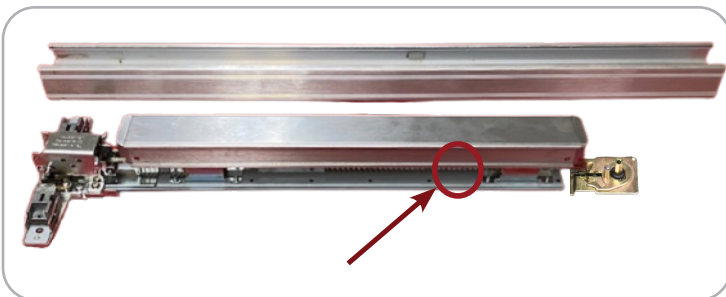

4. **Install Spacer** onto connecting rod in front of the back activating bracket to increase the return spring tension. Make sure Spacer is facing the correct direction.

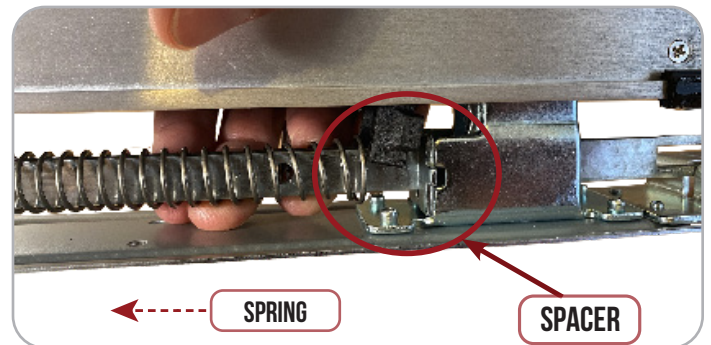

5. If your device has **Mechanical Dogging**, flip Baserail over & remove (2) screws securing dogging to Baserail.

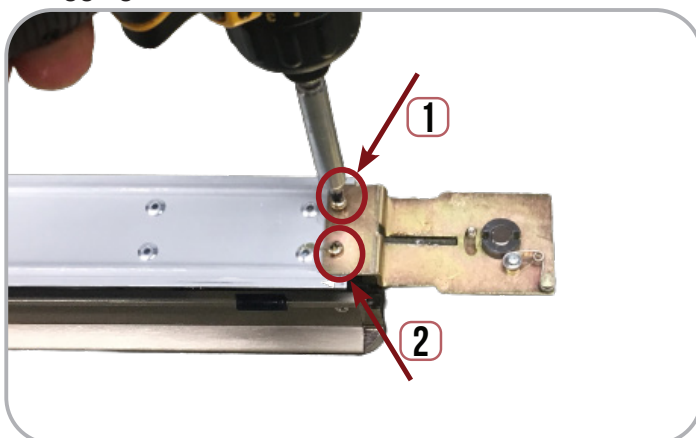

6. **Push Down** on Push Pad to extend connecting Rod's **Dogging Hole**.

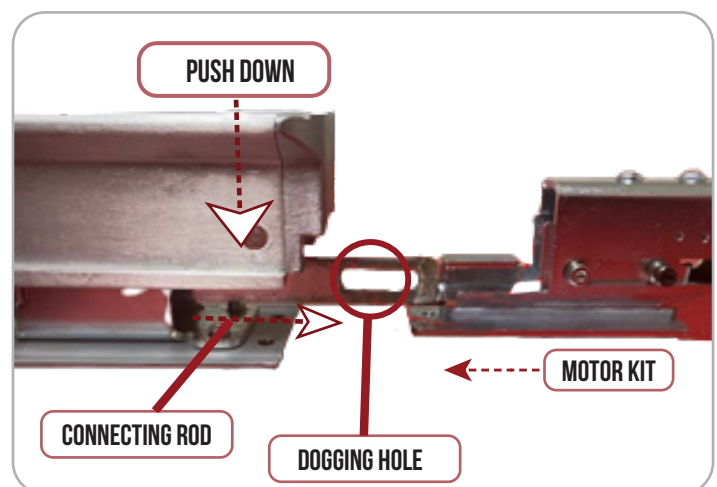

7. Slide Motor Kit's Attaching Arm into Dogging Hole. Make Sure the motor kit mounting bracket is on **TOP** of Baserail.

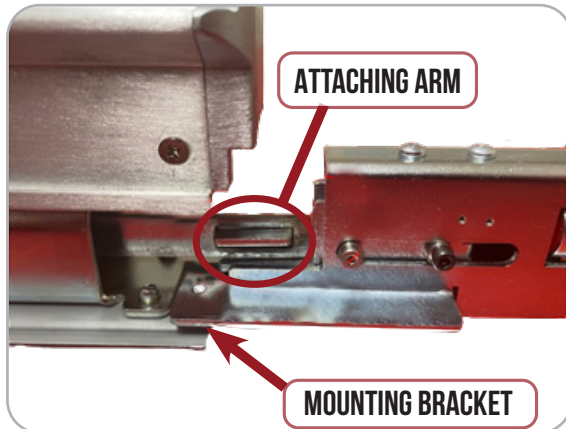

8. Flip Baserail/Pushpad over, holding motor kit in place so it stays attached. **Secure** Motor Kit with (2) M4 Screw provided.

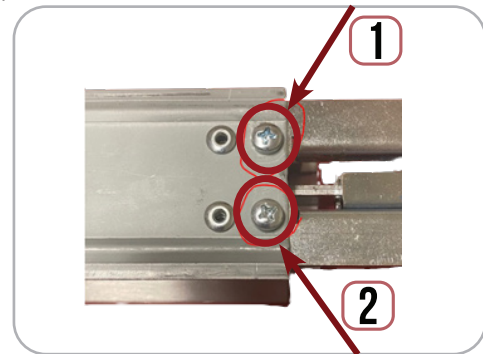

9. Slide Baserail motor side 1st back into the exit device Housing. **Make sure** the Motor & baserail go into the proper channels.

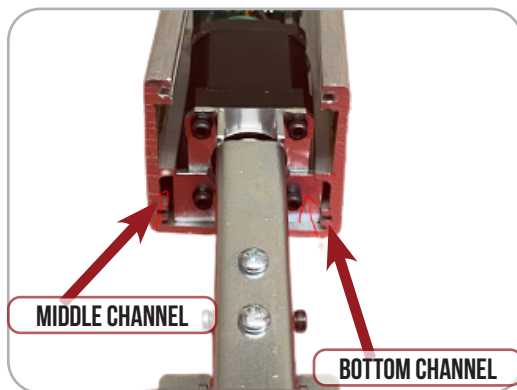

10. Re-install (2) Screws securing Housing to Baserail.

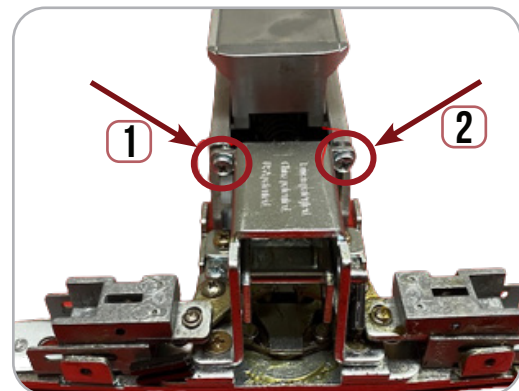

11. Set the "Push to Set Adjustment" following the steps below.



TO PUT THE DEVICE IN PTS MODE, FOLLOW THESE STEPS:

- Depress the MM5 button.
- Apply power and listen for short beep, which indicates that the device is now in PTS mode.
- Remove power.
- Release the button, but make sure you don't release it until the power is no longer going to the motor.

SET ADJUSTMENT:

- Depress the MM5 button.
- Depress the pushpad fully then release it 1/32", & hold.
- Apply power.
- Continue to hold the pushpad until the device gives you long beep.
- Remove power.

SETTING PUSH TO SET (PTS)

****IMPORTANT INFO****
MAKE SURE TO SET PTS BEFORE FINISHING INSTALLATION

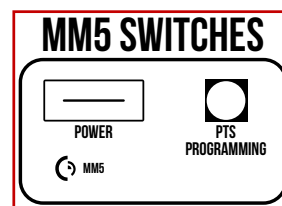

Note: Test the new location multiple times; if not to your liking, repeat the steps.