

STI WIRE GUARD DAMAGE STOPPER®

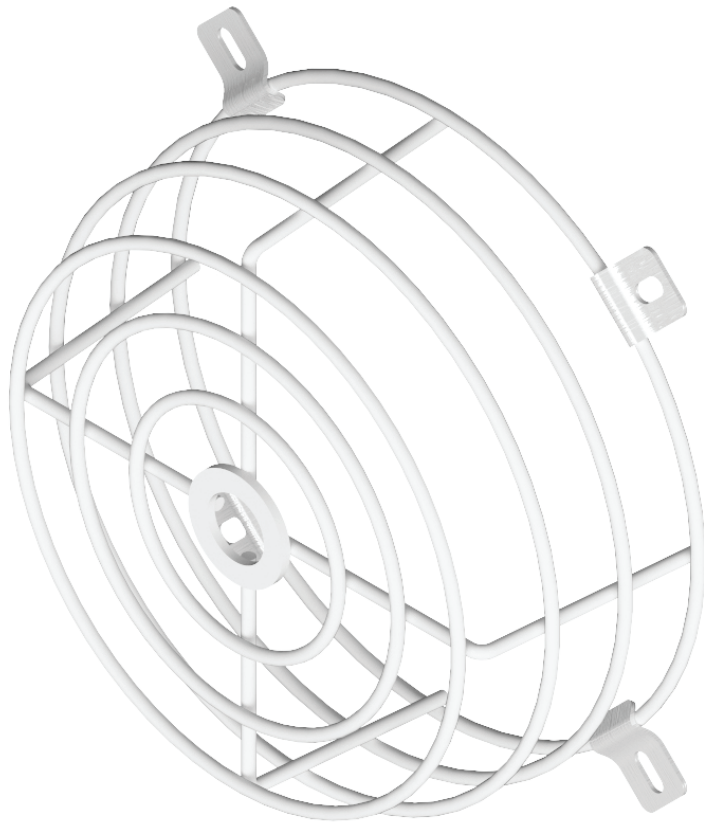

STI-9701

PRODUCT OVERVIEW

STI's super tough wire guard is the perfect solution to safeguard vape detectors and other vital air sensors from vandalism and accidental damage. The Stopper was created in response to numerous requests from valued STI customers. Installation is simple with the included fasteners. Servicing the detector is seamless, eliminating the need for guard removal. This cage is resistant to tampering when installed with optional tamper-resistant fasteners, ensuring the continued functionality of detectors in high-risk environments.

BACKED BY A THREE YEAR GUARANTEE

Constructed from 9-gauge steel wire coated with corrosion-resistant white polyester. The Stopper is extremely durable and recommended for areas where abuse is prevalent or where uninterrupted operation of detectors is imperative. Backed by a three year guarantee against breakage in normal use.

KEY FEATURES

General Information

- Helps protect vape detectors and more from vandalism, theft, and accidental damage.
- For use in a controlled environment (not intended for outdoor use).
- Three year guarantee against breakage in normal use.

Design

- Web-like octagon shape.
- 9-gauge steel wire makes them extremely difficult to break.

Construction

- Constructed of 9-gauge coated steel wire.
- Corrosion resistant polyester coating.

Installation

- Fast and easy installation with all screws and anchors provided.
- Requires minimal technical expertise or tools for installation.
- Mounting clamps and hardware included.
- Simple removal for servicing detector.
- Easy maintenance ensuring longevity and sustained effectiveness.

Options

- Tamper resistant hardware is available and recommended for areas where abuse is prevalent.

STI Wire Guard Damage Stopper®

Dimensions and Technical Information

MODELS AVAILABLE

STI-9701 Damage Stopper

WARRANTY

Three year guarantee against breakage in normal use.

Accessories

KIT-19038 Spanner bit for tamper resistant screws with 5/16 in. hex drive

KIT-82 Tamper resistant stainless steel screws, #8 X 1 1/2 in. snake eye (quantity 4)

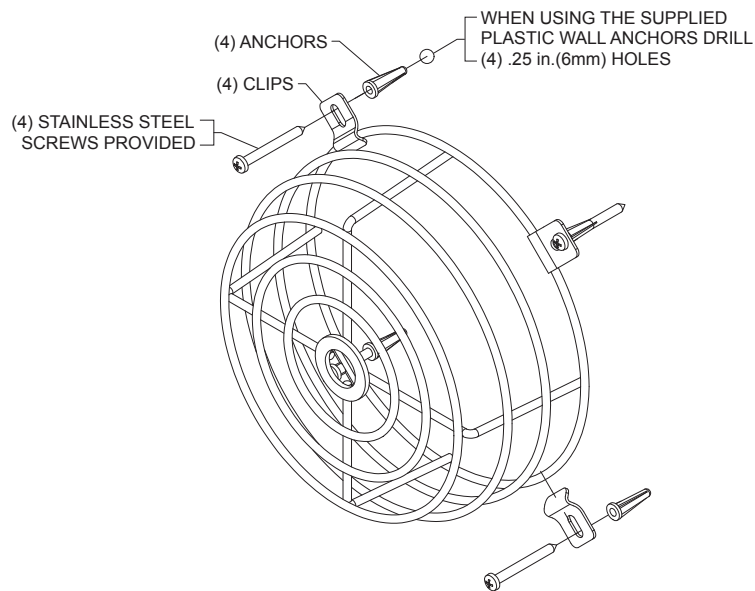
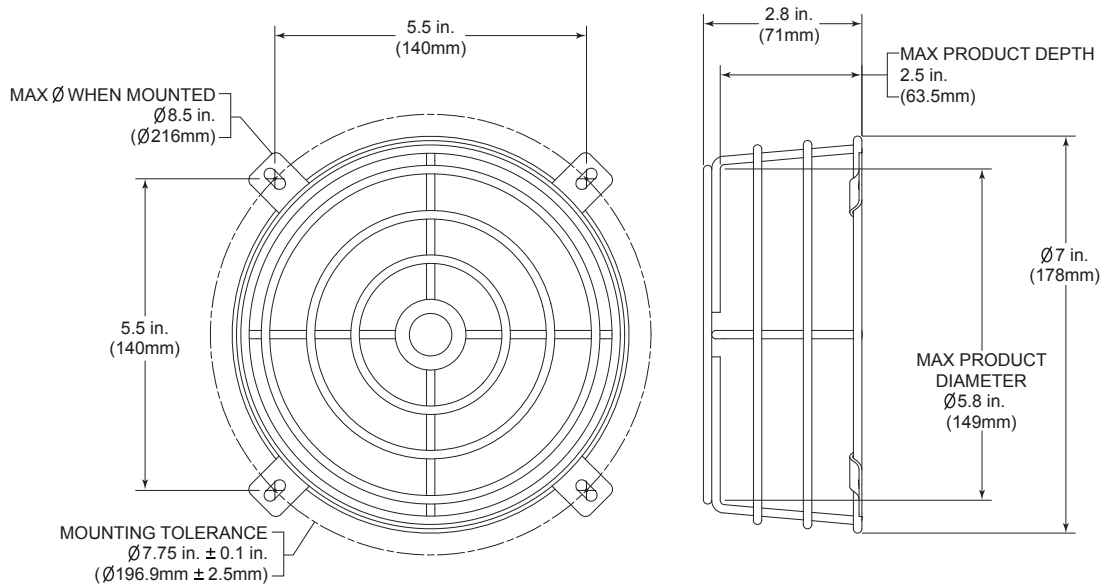

Safety Technology International

2306 Airport Road info@sti-usa.com
Waterford, MI www.sti-usa.com
48327, USA Tel: 248-673-9898

Taylor House
34 Sherwood Rd., Bromsgrove,
Worcs., B60 3DR, England

info@sti-emea.com
www.sti-emea.com
Tel: +44 (0) 1527 520 999

Unit 7A Lockheed Avenue
Airport Business Park
Waterford X91 HWF2 Ireland