

AREA OF REFUGE USER MANUAL AND INSTALLATION GUIDE

Read and save these instructions before installation and use

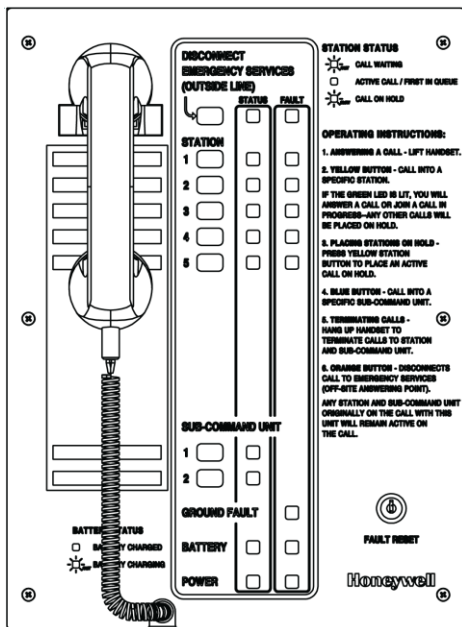

Model number(s)

HON-AOR-5*

HON-AOR-10*

DISCLAIMER

This document contains Talkaphone proprietary information.

Information contained herein is to be used solely for the purpose submitted, and no part of this document or its contents shall be reproduced, published, or disclosed to a third party without the express permission of Talk-A-Phone, LLC.

While this information is presented in good faith and believed to be accurate, Talkaphone disclaims the implied warranties of merchantability and fitness for a purpose and makes no express warranties except as may be stated in its written agreement with and for its customer.

In no event is Talkaphone liable to anyone for any direct, special, or consequential damages. The information and specifications in this document are subject to change without notice.

Talk-A-Phone and Talkaphone are registered trademarks of Talk-A-Phone, LLC. All rights reserved. Find out more at www.talkaphone.com.

The Honeywell trademark is used under license from Honeywell International Inc.

Honeywell International Inc. makes no representation or warranties with respect to these products. These products are manufactured by Talk-A-Phone, LLC, Niles, IL 60714, USA.

Copyright 2024 Talk-A-Phone, LLC

 <p>CAUTION</p>	<p>THIS PRODUCT MUST BE INSTALLED IN ACCORDANCE WITH THE NFPA 72 STANDARD.</p> <p>THIS PRODUCT MUST BE INSTALLED IN ACCORDANCE WITH THE APPLICABLE INSTALLATION CODE BY A PERSON FAMILIAR WITH THE CONSTRUCTION AND OPERATION OF THE PRODUCT AND THE HAZARDS INVOLVED.</p>
--	--

Table of contents

ABOUT THIS GUIDE.....	4
CONTENTS	5
TECHNICAL REQUIREMENTS	7
5-STATION WIRING DIAGRAM	9
10-STATION WIRING DIAGRAM.....	10
SYSTEM OVERVIEW	11
INTERNAL SYSTEM COMPONENTS – HON-AOR-5*	12
INTERNAL SYSTEM COMPONENTS – HON-AOR-10*	13
INSTALLATION	14
SYSTEM PROGRAMMING	21
OPERATING INSTRUCTIONS	32
SYSTEM FAULTS	34
SYSTEM MAINTENANCE	36
FREQUENTLY ASKED QUESTIONS	37
GENERAL TROUBLESHOOTING.....	38
SERVICING	39
LIMITED WARRANTY INFORMATION.....	40
SYSTEM INSTALLATION INFORMATION SHEET	41
OPERATING INSTRUCTION SHEET FOR THE COMMAND UNIT	42
OPERATING INSTRUCTIONS FOR SUB-COMMAND UNIT(s) – 5-STATIONS	43
OPERATING INSTRUCTIONS FOR SUB-COMMAND UNIT(s) – 10-STATIONS	44
FAULT CONDITIONS AND SERVICE CONTACT INSTRUCTION SHEET.....	45

About this guide

Scope

This installation guide describes how to install, program, operate, and maintain the Model Series **HON-AOR-5*** or Model Series **HON-AOR-10***.

For instructions on installation or programming of Area of Refuge (AOR) Call Stations, please refer to the manual for the HON-AOR-CS Call Station.

It is recommended that this instruction set be read completely prior to the start of any installation.

Revision history

Revision	Supported Release	Date	Description
1.0	Hardware 1.0 Software Releases FAORMAIN V2.1 and FAORAUX V1.3	May 22, 2024	<ul style="list-style-type: none"> Initial release of HON-AOR-5* and HON-AOR-10*.

Intended audience

This guide is primarily intended for field personnel who install and configure the product.

Related documents

The following list identifies publications that may contain information relevant to the information in this document:

- None at this time

 ATTENTION	This installation guide only applies to Software Release FAORMAIN V2.1 and FAORAUX V1.3.
--	--

Contents

Please ensure receipt of each of the included **HON-AOR-5 / HON-AOR-10** components:

Qty	Part Number	Description
1	HON-AOR-5-*, HON-AOR-10-*	5- or 10-Station Area of Refuge Command Unit
1	110-00009	12VDC, 9Ah Backup Battery

*-DKL has a door with keyed latch, -ETL is UL 2525 approved, -R provides a red enclosure instead of black

Accessory components (sold separately) include:

Qty	Part Number	Description
1	HON-AOR-PSU-5-10	Class 2 power supply with enclosure for HON-AOR-5* or HON-AOR-10* Command Unit. 115VAC input, 24VDC output.
1	HON-AOR-TR10	Flush mount trim ring for HON-AOR-5[-ETL] or HON-AOR-10[-ETL] Command Unit without door. Unit is painted black.
1	HON-AOR-TR10-R	Flush mount trim ring for HON-AOR-5*-R or HON-AOR-10*-R Command Unit without door. Unit is painted red.
1	HON-AOR-TR10-D	Flush mount trim ring for HON-AOR-5-DKL* or HON-AOR-10-DKL* Command Unit with door. Unit is painted black.
1	HON-AOR-TR10-D-R	Flush mount trim ring for HON-AOR-5-DKL*-R or HON-AOR-10-DKL*-R Command Unit with door. Unit is painted red.
1	42970	6-18 Phillips Screw for Flush Mount Trim Ring (for replacement).

(Continued) Accessory components (sold separately) include:

Qty	Part Number	Description
1	HON-AOR-SCU-1	Sub-Command Unit for HON-AOR-5* or HON-AOR-10* Command Unit. Up to two (2) supported for secondary on-site Area of Refuge answering points.
1	HON-AOR-CGW-4G-GSM	AT&T 4G/LTE cellular gateway for analog AOR systems. Does not include MIMO antenna kit (Model HON-AOR-CGW-ANT-6-KIT or HON-AOR-CGW-ANT-17-KIT).
1	HON-AOR-CGW-4G-V	Verizon 4G/LTE cellular gateway for analog AOR systems. Does not include MIMO antenna kit (Model HON-AOR-CGW-ANT-6-KIT or HON-AOR-CGW-ANT-17-KIT).
1	HON-AOR-CGW-ANT-17-KIT	MIMO antenna with 17-foot cable assembly. Includes U-bolts and 2-inch right-angle mounting bracket.
1	HON-AOR-CGW-ANT-6-KIT	MIMO antenna with 6-foot cable assembly. Includes U-bolts and 2-inch right-angle mounting bracket.

Technical Requirements

Programming

At time of installation or programming, please have either of the below ready:

- Connect a Sub-Command Unit or telephone test set to either the **SUB-C 1** or **SUB-C 2** terminal—DTMF programming commands can be issued from the built-in keypad of either of these devices.

The Sub-Command Unit (Model **HON-AOR-SCU-1**) is sold separately as an accessory.

A telephone test set can be purchased from any telecom retailer—examples include the Fluke TS30 Series or a basic corded trimline telephone.

- Or connect a PSTN/POTS telephone line (i.e. analog telephone line) to the **PSTN Line** terminal.

Please note the phone number of the telephone line—you will need that number in order to call from another telephone (e.g., cell phone). DTMF programming commands can be issued from the keypad of the device placing a call to the connected telephone line.

Power for Command Unit

For Command Units that are **not** UL 2525 approved, please provide either:

- **115VAC, 3.5A** when installed with Model **AOR-PSU-5-10** power supply (sold separately);
- Or a **regulated 24 VDC, 2A power source** (supplied by others).

 CAUTION	<p>FOR UL 2525 APPROVED COMMAND UNITS (I.E. MODEL NUMBERS WITH THE -ETL DESIGNATOR), SYSTEM MUST BE INSTALLED WITH OFFICIAL POWER SUPPLY MODEL HON-AOR-PSU-5-10 (SOLD SEPARATELY).</p> <p>THIS PRODUCT MUST BE INSTALLED IN ACCORDANCE WITH THE NFPA 72 STANDARD.</p>
--	---

Battery Backup

Backup battery specification is: **9Ah, valve regulated lead–acid (VRLA) battery**

Backup battery charging output is: **12VDC at 0.250A**

For a replacement battery, please order Talkphone P/N **110-00009**, Power Sonic **PS-1290 F2**, or an equivalent.

Power for HON-AOR-CS Call Stations

HON-AOR-CS Call Stations are line-powered by the **HON-AOR-5 / HON-AOR-10** Command Unit.

Cabling should meet these specifications:

- Twisted, shielded pair specifically designed for use with analog telephones
- Connect shield to earth ground at the Command Unit
- Recommended wire gauges along with the respective wire run distance ranges are provided in the table below:

Distance from Command Unit to HON-AOR-CS Call Station or Sub-Command Unit(s)	Recommended Wire Gauge
0 to 1,000 feet	24 AWG
1,001 to 1,500 feet	22 AWG
1,501 to 2,500 feet	20 AWG
2,501 to 3,500 feet	18 AWG

 ATTENTION	HON-AOR-CS Call Stations are connected to a Class B Pathway.
---	--

PSTN/POTS Telephone Line

For Local Mode Only:

No external phone line (i.e. POTS/PSTN telephone line) is required.

For Remote Mode:

One (1) dedicated POTS/PSTN telephone line (i.e. analog telephone line or analog PBX extension line).

If connected to a PBX, the analog extension must provide:

1. Minimum of 24V talk battery and 20 mA off-hook loop current
2. Either a CPC (Calling Party Control) disconnect pulse (voltage drop at end of call) or 30-seconds of silence after hang-up (no re-order or howler feature)

If connected to a POTS/PSTN line, there must be no special features, such as hook-flash, call-waiting, auto-redial when busy or voicemail. If the telephone company has activated any such features, contact them to have these features turned off.

5-Station Wiring Diagram

IMPORTANT NOTE:
 (A) Survivability requirements and regulations may vary depending on the local jurisdiction. Please contact your Authority Having Jurisdiction (AHJ) for further details.
 (B) Since fire-rated system requirements can vary from jurisdiction to jurisdiction, please approach a third-party firestop company for an "engineering judgment" or "firestop EJ".
 (C) Installation of components of the system into a fire-rated area or room may be required depending on the requirements of the jurisdiction.

Wiring Specifications for Each Call Station:
 (A) Maximum cable length will vary with wire gauge.
 (1) With 18 AWG wire, the supported distance range between Command Unit and Call Station is 2,501-3,500 ft.
 (2) With 20 AWG wire, the supported distance range between Command Unit and Call Station is 1,501-2,500 ft.
 (3) With 22 AWG wire, the supported distance range between Command Unit and Call Station is 1,001-1,500 ft.
 (4) With 24 AWG wire, the supported distance range between Command Unit and Call Station is 0-1,000 ft.
 (B) Twisted, shielded pairs are recommended with the shield connected to earth ground at the Command Unit end.

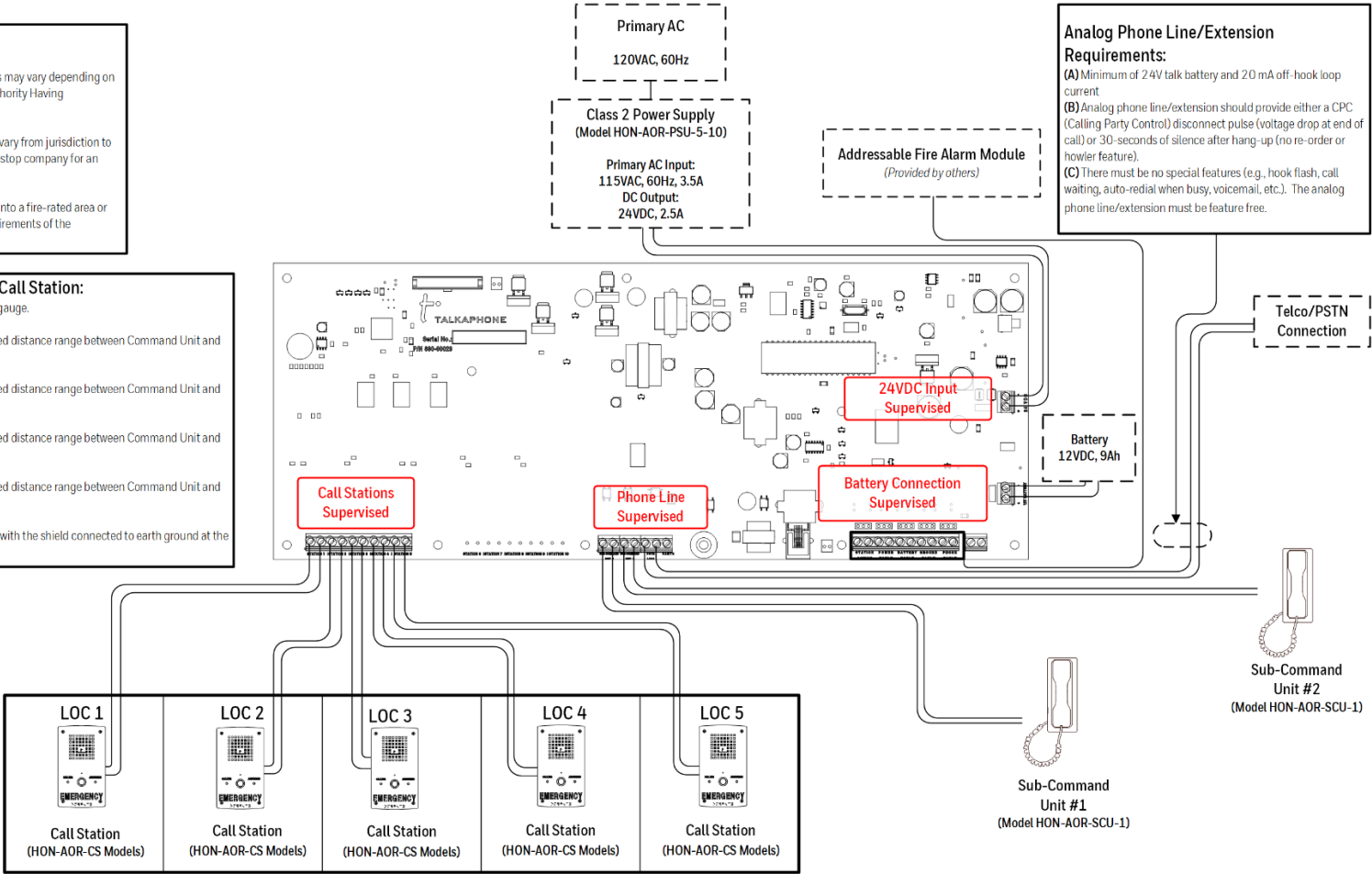

Analog Phone Line/Extension Requirements:
 (A) Minimum of 24V talk battery and 20 mA off-hook loop current
 (B) Analog phone line/extension should provide either a CPC (Calling Party Control) disconnect pulse (voltage drop at end of call) or 30-seconds of silence after hang-up (no re-order or howler feature).
 (C) There must be no special features (e.g., hook flash, call waiting, auto-redial when busy, voicemail, etc.). The analog phone line/extension must be feature free.

IMPORTANT NOTE:
 Call Stations are each connected to a CLASS B pathway.

10-Station Wiring Diagram

IMPORTANT NOTE:

- (A) Survivability requirements and regulations may vary depending on the local jurisdiction. Please contact your Authority Having Jurisdiction (AHJ) for further details.
- (B) Since fire-rated system requirements can vary from jurisdiction to jurisdiction, please approach a third-party firestop company for an "engineering judgment" or "firestop EJ".
- (C) Installation of components of the system into a fire-rated area or room may be required depending on the requirements of the jurisdiction.

Wiring Specifications for Each Call Station:

- (A) Maximum cable length will vary with wire gauge.
 - (1) With 18 AWG wire, the supported distance range between Command Unit and Call Station is 2,501-3,500 ft.
 - (2) With 20 AWG wire, the supported distance range between Command Unit and Call Station is 1,501-2,500 ft.
 - (3) With 22 AWG wire, the supported distance range between Command Unit and Call Station is 1,001-1,500 ft.
 - (4) With 24 AWG wire, the supported distance range between Command Unit and Call Station is 0-1,000 ft.
- (B) Twisted, shielded pairs are recommended with the shield connected to earth ground at the Command Unit end.

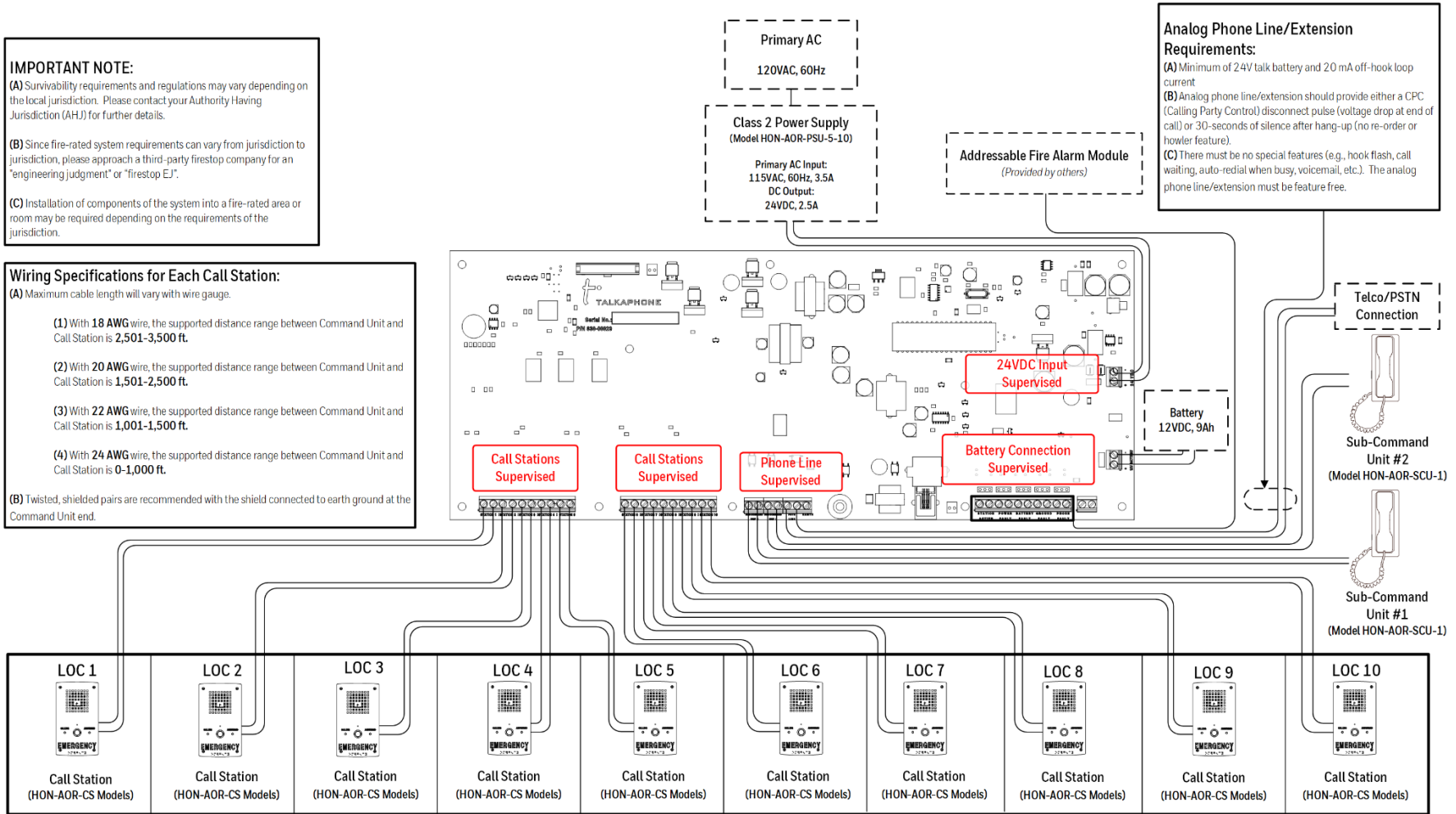

IMPORTANT NOTE:

Call Stations are each connected to a **CLASS B pathway**.

System Overview

Local Mode

In Local Mode, pressing the button on any of the Analog Call Stations will call the **HON-AOR-5 / HON-AOR-10** Command Unit and/or Sub-Command Unit(s).

Remote Mode

Remote Mode is primarily used when a central control point is not always constantly attended.

In Remote Mode, the Command Unit will allow any of the AOR-CS Call Stations access to a phone line for remote dial out.

In this mode, AOR-CS Call Stations can dial, in round robin fashion, from a list of up to five (5) phone numbers—this list can be comprised of a mix of remote phone numbers or local answering points (i.e. the **HON-AOR-5 / HON-AOR-10** Command Unit and/or Sub-Command Unit(s)).

For this configuration, connect an outside phone line or a cellular gateway (Model **HON-AOR-CGW-4G-***) to the **PSTN Line** terminal.

 ATTENTION	See, Technical Requirements (p.7), for outside phone line requirements.
--	---

Internal System Components – HON-AOR-5*

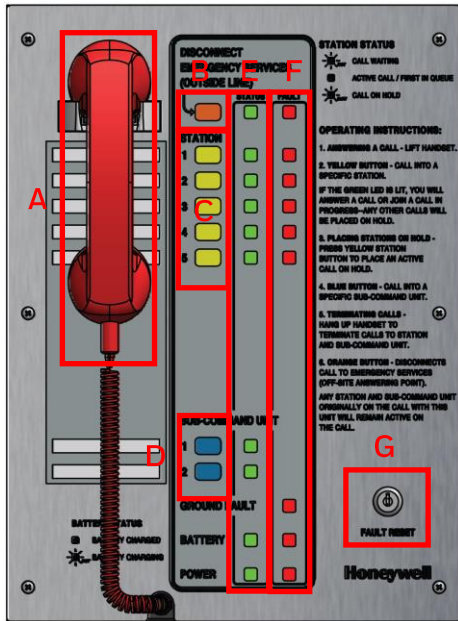

Item	Component
A	Local Handset
B	PSTN Line Disconnect Button
C	Call Station Selection Buttons
D	Sub-Command Unit Selection Buttons
E	Status LEDs
F	Fault LEDs
G	FAULT RESET Key Switch

Figure 1. Model HON-AOR-5*, front operating panel.

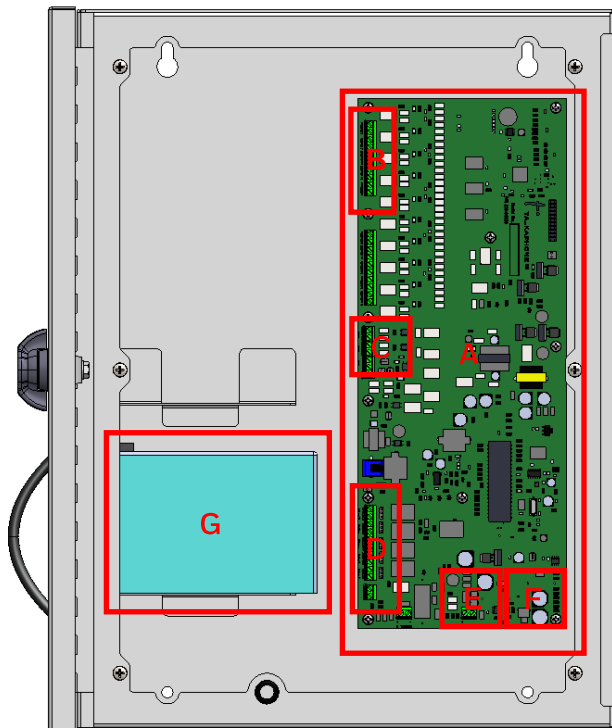

Item	Component
A	5-channel Controller Board
B	Call Station 1-5 Terminals
C	PSTN Line Terminal
D	Open/Short/System Ground Fault/HON-AOR-CS Call Station Activation Relay Outputs
E	24VDC Input Terminal
F	Orange-red Configuration Button
G	12VDC, 9Ah Backup Battery

Figure 2. Model HON-AOR-5*, internal components.

Internal System Components – HON-AOR-10*

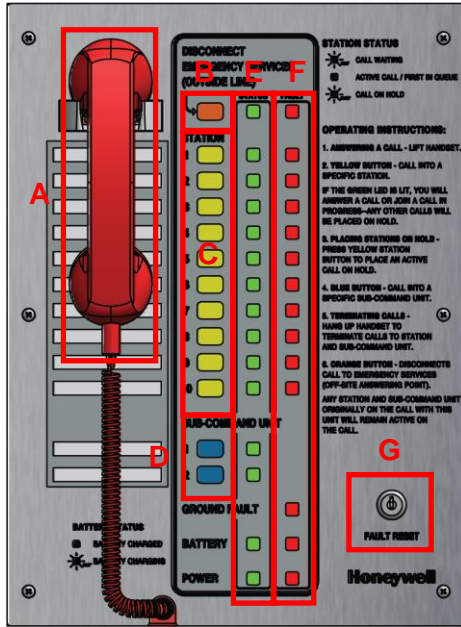

Item	Component
A	Local Handset
B	PSTN Line Disconnect Button
C	Call Station Selection Buttons
D	Sub-Command Unit Selection Buttons
E	Status LEDs
F	Fault LEDs
G	FAULT RESET Key Switch

Figure 3. Model HON-AOR-10*, front operating panel.

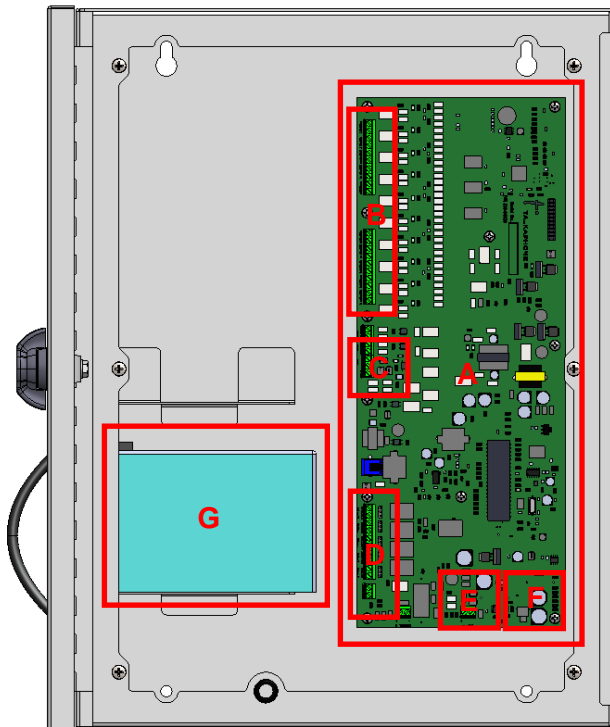

Item	Component
A	10-channel Controller Board
B	Call Station 1-10 Terminals
C	PSTN Line Terminal
D	Open/Short/System Ground Fault/HON-AOR-CS Call Station Activation Relay Outputs
E	24VDC Input Terminal
F	Orange-red Configuration Button
G	12 VDC, 9Ah Backup Battery

Figure 4. Model HON-AOR-10*, internal components.

Installation

1. Remove the **HON-AOR-5 / HON-AOR-10** unit from its packaging carton and inspect for any possible damage. If the unit is damaged or if any components are missing, please contact your distributor immediately.

Do not discard any hardware or packaging prior to checking for all included components listed above and ensuring that the unit is installed and functioning as expected.

2. **Model Configurations without Latched Door:**

Remove the six (6) screws from the stainless steel front panel. Carefully take the panel off the enclosure—there are cables connected to the front panel.

Model Configurations with Latched Door:

Open the latched door and remove the packaged front cover door handle. Install the handle onto the outside surface of the latched door using the provided screws.

Remove the six (6) screws from the stainless steel front panel. Carefully take the panel off the enclosure—there are cables connected to the front panel.

3. The **HON-AOR-5 / HON-AOR-10** unit may be either surface mounted or flush mounted to a wall.

 ATTENTION	For flush mounting configuration without the latched door, HON-AOR-5 / HON-AOR-10 units should be ordered with the available HON-AOR-TR10, HON-AOR-TR10-R, HON-AOR-TR10-D, or HON-AOR-TR10-D-R Flush Mount Trim Ring (sold separately).
---	---

For flush mounting configurations with latched door, **HON-AOR-5 / HON-AOR-10** units should be ordered with the available **HON-AOR-TR10-D** or **HON-AOR-TR10-D-R** Flush Mount Trim Ring (sold separately).

 CAUTION	Conduit knockouts exist on the left, right, and bottom sides of the cabinet for access to power and communication lines. Determine the method of bringing in these power and communication lines <u>before</u> mounting the enclosure.
--	--

 CAUTION	Whenever possible, it is best to keep the maximum clearance possible between analog phone lines and alternating current. Running phone lines too close to hot VAC lines will lead to noise or interference on the phone line.
--	---

4. **Surface Mounting onto an Interior Wall:**

The **HON-AOR-5 / HON-AOR-10** unit has four (4) surface mounting keyholes located on the rear of the chassis.

5. **Flush Mounting into an Interior Wall:**

The **HON-AOR-5 / HON-AOR-10** unit has six (6) screw points on the sides which can be used to mount the Command Unit within a wall.

Both halves of the **HON-AOR-TR10 / HON-AOR-TR10-R** trim ring (or **HON-AOR-TR10-D / HON-AOR-TR10-D-R** for latched door configurations) should be secured to the wall using the provided 6-18 screws.

6. Interfaces for HON-AOR-5* Controller Board

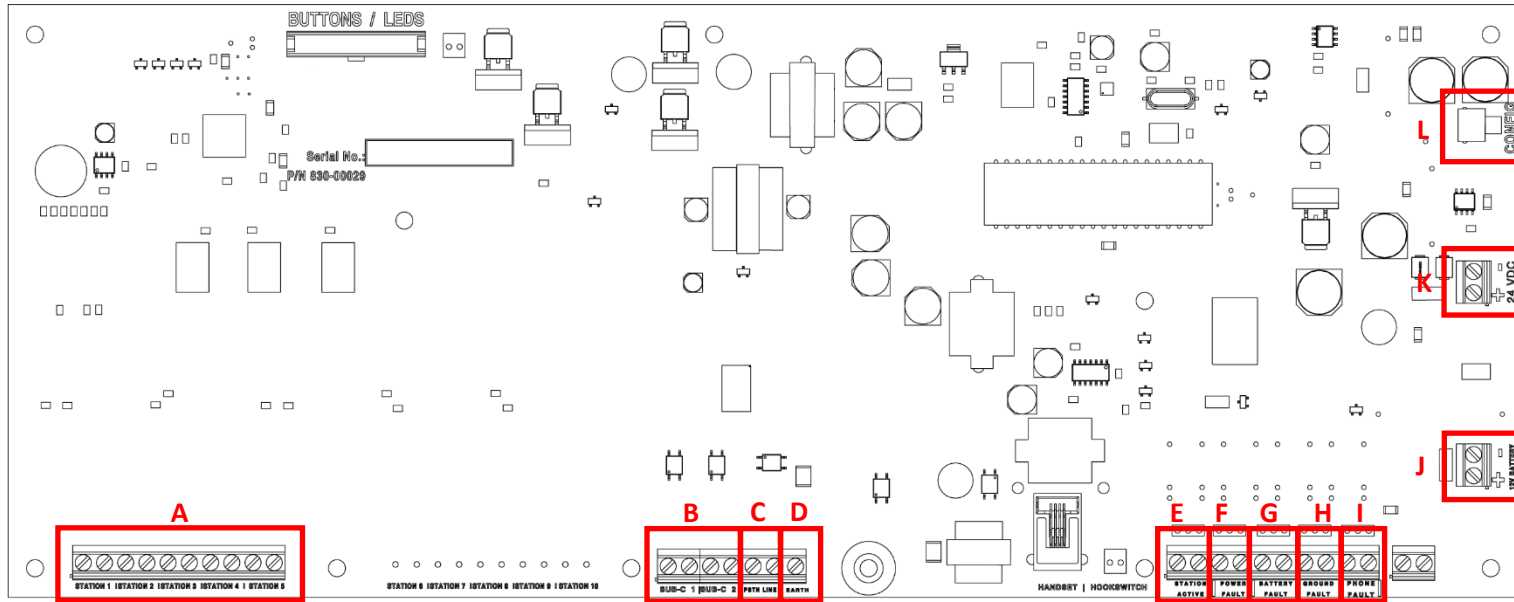

This section outlines the interfaces on the HON-AOR-5* controller board.

- (A) **STATION 1** – For the first HON-AOR-CS Call Station
STATION 2 – For the second HON-AOR-CS Call Station
STATION 3 – For the third HON-AOR-CS Call Station
STATION 4 – For the fourth HON-AOR-CS Call Station
STATION 5 – For the fifth HON-AOR-CS Call Station
- (B) **SUB-C 1** – Dedicated terminal for Sub-Command Unit #1
SUB-C 2 – Dedicated terminal for Sub-Command Unit #2
- (C) **PSTN LINE** – Connect an analog (PSTN/POTS) telephone line or analog PBX extension line for dialing off-site or to a remote answering point
- (D) **EARTH** – Connect Earth ground
- (E) **STATION ACTIVE** – This relay output (normally open, NO) will provide a contact closure when any HON-AOR-CS Call Station is activated
- (F) **POWER FAULT** – This relay output (normally open, NO) will provide a contact closure when there is a loss in 24VDC power
- (G) **BATTERY FAULT** – This relay output (normally open, NO) will provide a contact closure when the backup battery is disconnected or providing a low voltage output
- (H) **GROUND FAULT** – This relay output (normally open, NO) will provide a contact closure when a system ground fault is present
- (I) **PHONE FAULT** – This relay output (normally open, NO) will provide a contact closure when a short or open is present on any Call Station and PSTN Line terminal
- (J) **12V BATTERY** – Connect the included 12V backup battery
- (K) **24 VDC** – Connect a 24VDC power supply
- (L) **CONFIG** – This push button is used to configure the Call Station and PSTN Line terminals

7. Interfaces for HON-AOR-10* Controller Board

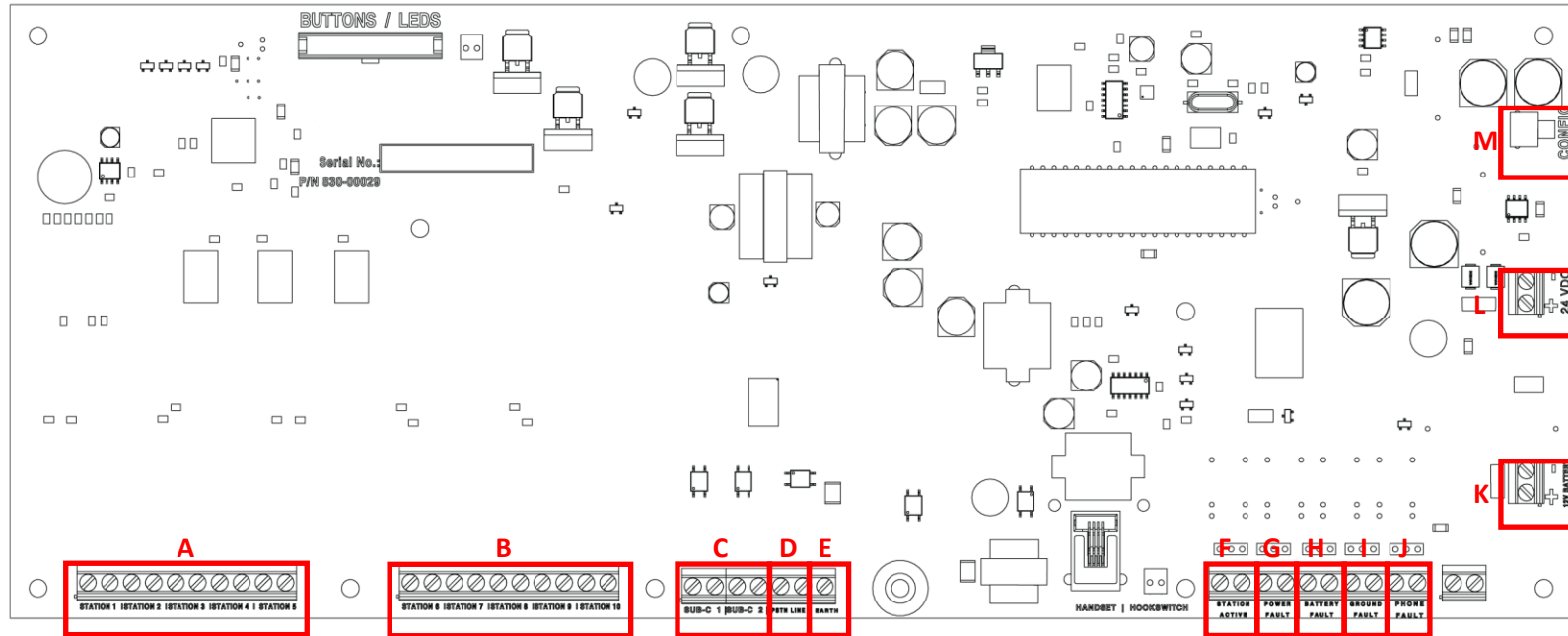

This section outlines the interfaces on the HON-AOR-10* controller board.

- (A) **STATION 1** – For the first HON-AOR-CS Call Station
STATION 2 – For the second HON-AOR-CS Call Station
STATION 3 – For the third HON-AOR-CS Call Station
STATION 4 – For the fourth HON-AOR-CS Call Station
STATION 5 – For the fifth HON-AOR-CS Call Station
- (B) **STATION 6** – For the sixth HON-AOR-CS Call Station
STATION 7 – For the seventh HON-AOR-CS Call Station
STATION 8 – For the eighth HON-AOR-CS Call Station
STATION 9 – For the ninth HON-AOR-CS Call Station
STATION 10 – For the tenth HON-AOR-CS Call Station
- (C) **SUB-C 1** – Dedicated terminal for Sub-Command Unit #1
SUB-C 2 – Dedicated terminal for Sub-Command Unit #2
- (D) **PSTN LINE** – Connect an analog (PSTN/POTS) telephone line or analog PBX extension line for dialing off-site or to a remote answering point
- (E) **EARTH** – Connect Earth ground
- (F) **STATION ACTIVE** – This relay output (normally open, NO) will provide a contact closure when any HON-AOR-CS Call Station is activated
- (G) **POWER FAULT** – This relay output (normally open, NO) will provide a contact closure when there is a loss in 24VDC power
- (H) **BATTERY FAULT** – This relay output (normally open, NO) will provide a contact closure when the backup battery is disconnected or providing a low voltage output
- (I) **GROUND FAULT** – This relay output (normally open, NO) will provide a contact closure when a system ground fault is present
- (J) **PHONE FAULT** – This relay output (normally open, NO) will provide a contact closure when a short or open is present on any Call Station and PSTN Line terminal
- (K) **12V BATTERY** – Connect the included 12V backup battery
- (L) **24 VDC** – Connect a 24VDC power supply
- (M) **CONFIG** – This push button is used to configure the Call Station and PSTN Line terminals

- 8. The **HON-AOR-5*** can support up to five (5) HON-AOR-CS Call Stations and the **HON-AOR-10*** can support up to ten (10) HON-AOR-CS Call Stations.

The HON-AOR-CS Call Stations can dial out through an analog (PSTN/POTS) telephone line, to the local handset on the Command Unit, or to a Sub-Command Unit.

- 9. **Routing Cabling:**

Route the HON-AOR-CS Call Station cabling and the analog (PSTN/POTS) telephone line (depending on the local jurisdiction, may or may not be required) through the conduit knockouts located on the left, right, or bottom sides of the Command Unit. Always try to separate power lines from communication lines in order to mitigate the risks of noise or interference on the communication lines.

- 10. **Terminating HON-AOR-CS Call Station Cabling:**

Terminate the cabling for each HON-AOR-CS Call Station to **Station 1 through Station 5 (or through Station 10)**.

The tip and ring connections for the HON-AOR-CS Call Stations are **NOT** polarity sensitive.

 ATTENTION	HON-AOR-CS Call Stations are connected to a Class B Pathway.
--	--

- 11. **Terminating PSTN/POTS Telephone Line for Off-site Dialing:**

If an analog (PSTN/POTS) telephone line, analog PBX extension line, or cellular gateway is to be used for off-site dialing, terminate the analog telephone line or PBX extension line to the **PSTN Line** terminal on the controller board—this connection is **NOT** polarity sensitive.

Each **HON-AOR-5 / HON-AOR-10** Command Unit supports one (1) dedicated POTS/PSTN telephone line or cellular gateway.

 ATTENTION	See, Technical Requirements (p.7), for analog PSTN/POTS telephone line specifications.
--	--

12. Connecting Primary Power:

Once the appropriate low voltage field cabling terminations have been completed, connect the primary power (24VDC, 2A) to the controller board—the power input connector is located at the center-bottom of the controller board.

Earth ground should be connected to the **Earth Ground** terminal on the center-left side of the controller board.

 ATTENTION	The Command Unit will only power on when primary power is connected. If the backup battery is connected first, the Command Unit will not power on until primary power is connected to the system.
--	---

 CAUTION	It is the installer’s obligation to ensure compliance with all national, regional, and local regulations.
--	---

13. Fault Detection Configuration for HON-AOR-CS Call Stations and PSTN Line:

Carrying out this procedure on the controller board is required for proper open/short fault and PSTN/POTS telephone line fault detection on the system.

In the lower-right of the controller, there is an orange-red configuration button.

Once you have the HON-AOR-CS Call Stations and the PSTN/POTS telephone line (if required) terminated to the controller board, press and hold the orange-red button for three (3) seconds—the LED will flash rapidly. When the LED turns solid, release the orange-red button. You will hear a beep to confirm that configuration has been completed.

 ATTENTION	Before carrying out this procedure for configuring fault detection and utilizing the orange-red button, please check and make sure that the handset is fully seated in the cradle on the front operating panel. Alternatively, the HOOKSWITCH connection on the controller board can be temporarily disconnected while carrying out this fault detection configuration procedure. After completing configuration, please ensure that the HOOKSWITCH connection has been fully reconnected.
--	---

14. Connecting the Backup Battery:

Install the backup battery inside the Command Unit cabinet and connect its faston tabs to the appropriately marked battery cable—black goes to black, red goes to red.



CAUTION

It is the installer's obligation to ensure compliance with all national, regional, and local regulations.



CAUTION

It is the installer's obligation to mark the "date of installation" on each battery.

System Programming

List of Programming Codes for the Command Unit

Command	Function
* 31 * [up to 8 digits] *	Guard Access Code entry for phone programming [Default * 31 * *]
* 30 * [up to 8 digits] *	Master Access Code entry to change Guard Access Code, Master Access Code, and/or factory default the unit [Default * 30 * 12345678 *]
* 30 * 14725836 *	Resets controller board programming to factory defaults. Requires prior Master Access Code entry.
* 32 * [up to 8 digits] *	Programs and stores a new Master Access Code. Requires prior Master Access Code entry.
* 33 * [up to 8 digits] *	Programs and stores a new Guard Access Code. Requires prior Master Access Code entry.
* 34 * [1 to 99] *	Sets number of rings before controller board picks up when it is dialed (1 to 99) [Default 3]
* 37 *	Local Mode NOTE: All calls will route to the Command Unit handset and/or Sub-Command Unit(s).
* 38 * [1 to 24] *	PSTN line test interval in hours (1-24 hours) [Default 23]
* 39 * 1 *	PSTN line is a Central Office (CO) line from the telephone company (allows 9 transfers) [Default]
* 39 * 2 *	PSTN line is a PBX extension (disables 9 transfers)

(Continued) List of Programming Codes for the Command Unit

Command	Function
* 55 * [00 to 21] *	<p>Sends a touch tone asterisk (*) once the configured period of time (in seconds) has elapsed after picking up the Command Unit handset.</p> <p>This programming code is only used in a scenario where an AOR-CS Call Station is configured with the Command Unit handset as the primary number, with an outside (PSTN) phone number as a secondary number, and with a repeating (i.e. looping) voice message.</p> <p>[Default 00 for disabled]</p> <p>[01 for 1-second, 02 for 2-seconds, ... , 21 for 21-seconds]</p>
* 56 * 1 *	<p>Ignore any inbound PSTN line call when Call Stations, Command Unit, and/or Sub-Command Unit(s) are active</p> <p>[Default]</p>
* 56 * 2 *	<p>Allow any inbound PSTN line call to barge in when Call Stations, Command Unit, and/or Sub-Command Unit(s) are active</p>
* 57 *	<p>Erase the "On Hold" voice message for calls in queue or on hold</p>
* 58 *	<p>Record the "On Hold" voice message for calls in queue or on hold.</p> <p>Press the # key to stop recording or it will end after 50 seconds. The recorded message will automatically play back.</p>
* 59 *	<p>Preview the recorded "On Hold" voice message for calls in queue or on hold</p>
* 62 *	<p>Remote Mode</p> <p>[Default]</p>

List of Operational Codes for the Command Unit

Command	Function
* 4 [1 through 5 or 0 through 9] *	<p><u>Use only to establish two-way communication with a HON-AOR-CS Call Station:</u></p> <p>Enter this code when connected through a Sub-Command Unit or a remote PSTN call – routes to a specific HON-AOR-CS Call Station on Station #1-5 or #1-10.</p> <p>Does not require Guard Access Code or Master Access Code entry.</p>
* 4 # *	<p>HON-AOR-CS Call Station all call when connected through a Sub-Command Unit or a remote PSTN call.</p> <p>Does not require Guard Access Code or Master Access Code entry.</p>
* 7 [1 through 5 or 0 through 9] *	<p><u>Use only to program HON-AOR-CS Call Stations:</u></p> <p>Enter this code when connected through a Sub-Command Unit or a remote PSTN call—routes to a specific HON-AOR-CS Call Station on Station #1-5 or #1-10.</p> <p>This code allows for DTMF transmission from the Command Unit to the HON-AOR-CS Call Station for programming.</p>
5	<p>Call the Command Unit handset.</p> <p>Dial this number from an HON-AOR-CS Call Station, Sub-Command Unit, or remote PSTN call.</p> <p>Does not require Guard Access Code or Master Access Code entry.</p>
6	<p>Call Sub-Command Unit #1.</p> <p>Dial this number from an HON-AOR-CS Call Station, Sub-Command Unit #2, or remote PSTN call.</p> <p>Does not require Guard Access Code or Master Access Code entry.</p>
7	<p>Call Sub-Command Unit #2.</p> <p>Dial this number from an HON-AOR-CS Call Station, Sub-Command Unit #1, or remote PSTN call.</p> <p>Does not require Guard Access Code or Master Access Code entry.</p>
8	<p>Call Command Unit handset and Sub-Command Unit(s).</p> <p>Dial this number from an HON-AOR-CS Call Station or remote PSTN call.</p> <p>Does not require Guard Access Code or Master Access Code entry.</p>

(Continued) List of Operational Codes for the Command Unit

Command	Function
9	Switch to a CO line (requires * 37 * and * 39 * 1 *) Does not require Guard Access Code or Master Access Code entry.
#	Terminate connection when not recording the "On Hold" voice message

Programming the Command Unit

1. There are two (2) methods to program the Command Unit:
 - Via the keypad on a Sub-Command Unit (or any telephone test set);
 - Remotely by calling the phone number of the connected PSTN/POTS telephone line.

In either case, the Command Unit will answer and output one (1) beep.

2. When entering programming codes, the controller board will provide the following feedback:

System Feedback	Definition or Meaning
One (1) Beep	Programming code successfully accepted
Two (2) Beeps	Error code—please re-enter the programming code

If you hear two (2) beeps or silence, re-enter the programming code again. If you continue to hear two (2) beeps or silence a second time, hang up and try again.

3. **Remote Mode:**

1. Pick up a Sub-Command Unit handset (or remotely call into the connected PSTN/POTS telephone line) and listen for one (1) beep.
2. Enter the Guard Access Code to enter programming mode: ***31****
3. Program the controller board for Remote Mode: ***62***
4. Program the controller board for the type of PSTN/POTS telephone line:

39*1 for a CO line from the telephone company (allows 9 transfers)

39*2 for a PBX extension (disables 9 transfers)

5. Recording the “On Hold” Voice Message for Calls in Queue or on Hold:
 - a. To begin recording, enter: ***58***
Wait for the tone to begin speaking/recording. The recorded message has a maximum length of **50 seconds**.
 - b. Press the # key to stop recording or it will end after 50 seconds. The recorded message will automatically play back.
 - c. To review the recorded message again, press: ***59***
 - d. To delete the recorded message, press: ***57***

6. To exit programming and disconnect, hang up the call or press: #
7. Move onto **Programming the HON-AOR-CS Call Stations.**

4. **Local Mode:**

1. Pick up a Sub-Command Unit handset and listen for one (1) beep.
2. Enter the Guard Access Code to enter programming mode: ***31****
3. Program the controller board for Local Mode: ***37 ***
4. Recording the "On Hold" Voice Message for Calls in Queue or on Hold:

- a. To begin recording, enter: ***58***

Wait for the tone to begin speaking/recording. The recorded message has a maximum length of **50 seconds**.

- b. Press the # key to stop recording or it will end after 50 seconds. The recorded message will automatically play back.
- c. To review the recorded message again, press: ***59***
- d. To delete the recorded message, press: ***57***

5. To exit programming and disconnect, hang up the call or press: #
6. Move onto **Programming the HON-AOR-CS Call Stations.**

Programming the HON-AOR-CS Call Stations

Once the **HON-AOR-5 / HON-AOR-10** Command Unit has been programmed, the HON-AOR-CS Call Stations will need to be programmed individually.

1. Calling into the HON-AOR-CS Call Station to enter programming mode.
 1. To call from a remote phone, dial the telephone number of the analog (PSTN/POTS) telephone line connected to the Command Unit. Go to **Step (3)**.
 2. To call from a Sub-Command Unit, simply pick up the handset.
 3. In either case, you will hear one (1) beep when the Command Unit is ready.
 4. Enter the code to route to a specific HON-AOR-CS Call Station:

*** 7 [1 through 5 or 1 through 0] ***

There will be a short pause and then the HON-AOR-CS Call Station will answer with an open channel (microphone and speaker are active).



ATTENTION

After each HON-AOR-CS Call Station programming code, two (2) beeps indicate the code has been accepted. Four (4) beeps indicate an error—re-enter the code again.

2. Enter the security code: **827827**
3. Program the Primary Phone Number to dial: **[0-20 digits for phone number] # 00**

For **local mode**, use **any of the following numbers** as the phone number:

5 calls the Command Unit handset

6 calls Sub-Command Unit #1

7 calls Sub-Command Unit #2

8 calls the Command Unit handset and the Sub-Command Unit(s)—rings all at the same time, first to pick up answers the call

For **remote mode** (i.e. calling an outside phone number), use the **10-digit phone number** of the answering point as the phone number.

Please program the phone number in the following format depending on whether a PSTN/POTS telephone line, analog PBX extension line, or cellular gateway is connected.

For a Central Office (CO) line from the telephone company or cellular gateway: **9 + 1 + Area Code + 7-digit Phone Number**

For a PBX extension: **1 + Area Code + 7-digit Phone Number**

4. Program the Second Phone Number to dial: **[0-20 digits for phone number] # 01**

Follow the same dialing rules as outlined in **Step (3)** above.

5. Set the call length, silence time out, ring count, and dial next number on busy:

294521 # 18

See **Timing/Dialing Options for the HON-AOR-CS Call Station (p.29)** for further details or other options.

6. Recording a Location Message:

1. Record the location message for the HON-AOR-CS Call Station in question: *** 4**

Wait for the tone to begin speaking/recording. The recorded message has a maximum length of **16 seconds**.

2. Press any key to stop recording or it will end after 16 seconds. The recorded message will automatically play back.
3. To review the recorded message again, press: *** 5**
4. To delete the recorded message, press: *** 3**

7. To exit programming and disconnect, press: **# 7**

List of Programming Codes for the HON-AOR-CS Call Station

Command	Memory Slot	Function
0-20 digits	#00	Primary autodial phone number *
0-20 digits	#01	Secondary autodial phone number *
0-20 digits	#02	Third autodial phone number *
0-20 digits	#03	Fourth autodial phone number *
0-20 digits	#04	Fifth autodial phone number *
6 digits	#18	Timing/dialing options. For further details, see “ Timing/Dialing Options for the HON-AOR-CS Call Station ” on p.29. [Default 234721]
6 digits	#19	Change the security code [Default 827827 or TAPTAP]
* 7		Add 4-second pause at any point of the dial string
[Enter No Digits]	#00 through #04	Clear autodial phone numbers
# 7		Exit programming mode and disconnect
# # #		Reset to factory defaults

 NOTE	<p>* For Remote Mode with a CO Line connected, the dial string should be set to the following format to route the call through the <u>PSTN Line</u> port:</p> <p style="text-align: center;">9 + 1 + Area Code + 7-digit Phone Number</p> <p>Alternatively, any of the following numbers can be set as a phone number to reach local answering points:</p> <p style="text-align: center;"><u>5</u> calls the Command Unit handset</p> <p style="text-align: center;"><u>6</u> calls Sub-Command Unit #1</p> <p style="text-align: center;"><u>7</u> calls Sub-Command Unit #2</p> <p style="text-align: center;"><u>8</u> calls the Command Unit handset and the Sub-Command Unit(s)—rings all at the same time, first to pick up answers the call</p>
---	--

 ATTENTION	<p>After each HON-AOR-CS Call Station programming code, two (2) beeps indicate the code has been accepted. Four (4) beeps indicate an error—re-enter the code again.</p>
--	--

Timing/Dialing Options for the HON-AOR-CS Call Station

The timing/dialing option code is comprised of six (6) digits defined in the table below.

Parameter	Function	Values	Definition
A	Talk/Listen Delay. Switching time between talk and listen modes (i.e. VOX switching time).	1	0.1 seconds
		2	0.2 seconds [Default]
		3	0.3 seconds
		4	0.4 seconds
		5	0.5 seconds
		6	0.6 seconds
		7	0.7 seconds
		8	0.8 seconds
		9	0.9 seconds
B	Call Length. Sets maximum length of time the HON-AOR-CS Call Station can be connected to a call.	0	Disabled
		1	1 minute
		2	2 minutes
		3	3 minutes [Default]
		4	4 minutes
		5	5 minutes
		6	6 minutes
		7	7 minutes
		8	8 minutes
9	9 minutes		

(Continued) Timing/Dialing Options for the HON-AOR-CS Call Station

Parameter	Function	Values	Definition
C	Silence Time Out. Sets the length of time a call will be connected without any voice transmission.	0	Disabled
		1	10 seconds
		2	20 seconds
		3	30 seconds
		4	40 seconds [Default]
		5	50 seconds
		6	60 seconds
		7	70 seconds
		8	80 seconds
		9	90 seconds
D	Dial Next Number Timer. Sets the number of rings before the HON-AOR-CS Call Station dials the next phone number in the number list.	0 or 1	Disabled
		2, 3, 4, ... , 9	Dials next number after 2, 3, 4, ... , 9 rings
E	Dial Next Number on Busy. When a busy is detected the HON-AOR-CS Call Station will dial the next phone number in the number list.	1	Disabled
		2	Enabled [Default]
F	Not Used	Always set to 1 .	-

Operating Instructions

General Information

When the push button on the HON-AOR-CS Call Station is pressed, it will automatically either ring the Command Unit handset, the Sub-Command Unit(s), or dial out using the phone line connected to the PSTN Line terminal according to how the controller board is programmed (i.e. local mode or remote mode).

When a call comes into the HON-AOR-5 / HON-AOR-10 Command Unit, an LED will light indicating which HON-AOR-CS Call Station is calling in. If a call is already in progress, any other calls which come in will cause the appropriate LED to blink to indicate they are awaiting an open line—if recorded and configured, the “On Hold” voice message will also playback at the HON-AOR-CS Call Stations in queue. Alternatively, a double ring back will be heard at the HON-AOR-CS Call Station(s) in queue.

As soon as the initial call has been completed, any calls that were waiting will be put through in the order in which they were placed.

Calling Into HON-AOR-CS Call Stations from the Command Unit

1. To call from a remote phone, dial the telephone number of the phone line connected to the command unit—you will hear one (1) beep when the system is ready. Go to **Step (4)**.
2. To call from the Command Unit, simply pick up the handset—you will hear one (1) beep when the system is ready.
Press the button dedicated to the particular HON-AOR-CS Call Station. Go to **Step (5)**.
3. To call from a Sub-Command Unit, simply pick up the handset—you will hear one (1) beep when the system is ready. Go to **Step (4)**.
4. Enter the code to route to a specific HON-AOR-CS Call Station:
*** 4 [1 through 5 or 1 through 0] ***
5. There will be a short pause and then the HON-AOR-CS Call Station will answer with an open channel (microphone and speaker are active).

Answering Calls at the Command Unit

1. When calls are routed to the Command Unit handset, the Command Unit will ring.
2. To answer the call, pick up the Command Unit handset.
3. A prerecorded voice message with physical location information may play at the beginning of the call.

Answering Calls at a Sub-Command Unit

1. When calls are routed to a Sub-Command Unit, the Sub-Command Unit will ring.
2. To answer the call, pick up the Sub-Command Unit handset.
3. A prerecorded voice message with physical location information may play at the beginning of the call.

Answering Calls Off-site or at a Central Station

When calls are routed off-site (i.e. monitoring service, call center, central station, or 911), calls are answered accordingly and a prerecorded voice message with physical location information may play at the beginning of the call.

All Call to HON-AOR-CS Call Stations

- From either Sub-Command Unit or through a remote PSTN call, enter * 4 # *. This command will call every HON-AOR-CS Call Station and initiate a one-way audio page.
- An all call initiated through a remote PSTN call has a 90 second limit.
- An all call initiated through a Sub-Command unit does not have a time limit.
- This operation command does not require initial entry of the Guard Access Code or the Master Access Code.

System Faults

Fault Conditions

- **Audible Indicator** – When any fault occurs, a steady tone will be emitted from the Command Unit.
- **Visual Indicator for Opens** – When an open occurs on an HON-AOR-CS Call Station cable run, the respective **FAULT** LED(s) will flash on the Command Unit panel indicating the specific call station location(s) with the fault.
- **Visual Indicator for Shorts** – When a short occurs on an HON-AOR-CS Call Station cable run, the respective **FAULT** LED(s) will flash on the Command Unit panel indicating the specific call station location(s) with the fault.
- **Visual Indicator for PSTN/POTS Telephone Line Fault** – When the PSTN/POTS telephone line has an open or a short, the **OUTSIDE LINE FAULT** LED will flash on the Command Unit panel.
- **Visual Indicator for System Ground Fault** – When a system ground fault occurs at the Command Unit, the **GROUND FAULT** LED will flash on the Command Unit panel.
- **Visual Indicator for Battery Fault** – When a battery fault occurs at the Command Unit, the **BATTERY FAULT** LED will flash on the Command Unit panel.
- **Visual Indicator for Power Fault** – When a primary power loss occurs at the Command Unit, the **POWER FAULT** LED will flash and the **POWER** LED will disengage on the Command Unit panel.

Correcting Faults

- **Opens/Shorts on an HON-AOR-CS Call Station Cable Run** – Check cable for continuity and repair or replace cable.
- **Opens/Shorts on the PSTN/POTS Telephone Line Cable Run** – Check cable for continuity and repair or replace cable.
- **System Ground Faults** – Check the Command Unit for proper electrical grounding and correct any ground loops.
- **Battery Faults** – Check the voltage level of the backup battery. Replace the battery if the voltage level is low.
- **Power Faults** – Check that primary power is available—restore primary power.

Temporarily Silencing a Fault Condition

Use the **FAULT RESET** key switch to silence the audible fault indicator. The audible alarm will be temporarily silenced until the next timed supervisory test occurs (programmable with a factory default of every 23 hours). If the fault remains during the next timed supervisory test, the audible alarm will be provided again.

The LED fault indicators will remain in their trouble condition until the faults have been fully corrected. An audible double beep will also be heard when the **FAULT RESET** key switch is toggled to silence the alarm.

Resetting Fault Condition

When any faults have been corrected, use the **FAULT RESET** key switch on the Command Unit panel to have it conduct its supervisory tests and clear audible and visual alarms for any corrected faults.

Any faults that have not been corrected will continue to provide a visual alarm. The audible alarm will return on the next timed supervisory test (programmable with a factory default of every 23 hours) if the fault is still present.

Primary Power Loss

When the Command Unit loses primary power and begins to run on battery backup, the **POWER** LED will disengage (turn off) and the **POWER FAULT** LED will flash on the Command Unit panel.

The **POWER** LED will illuminate and the **POWER FAULT** LED will disengage once the primary power has been restored.

System Maintenance

NFPA 72 requires that area of refuge two-way communication systems be **inspected, tested, and maintained** on an **annual basis**. NFPA 72 specifies the method required as “verify location and condition”.

As such, the following guidelines are highly recommended:

- An annual inspection and testing be scheduled as part of the facility/building preventative maintenance schedule
- Each HON-AOR-CS Call Station should be inspected and tested.
- The Command Unit should be inspected and tested.
- The Sub-Command Unit should be inspected and tested.
- Verify the condition of the backup battery and replace if necessary.

Frequently Asked Questions

1. Can the system support more than one (1) local answering point?

Yes, in addition to the Command Unit handset as the main local answering point, the system supports up to two (2) Sub-Command Units as additional local answering points.

2. If I have more than one Command Unit can each one be connected to same PSTN/POTS telephone line?

Because an Area of Refuge system is considered a life safety system, each HON-AOR-5 / HON-AOR-10 Command Unit requires a dedicated telephone line.

3. If I forgot the Master Access Code or the programming configuration, can I reset the programming on the Command Unit?

If you have forgotten your Master Access Code or the programming configuration, you can reset the programming to factory defaults through the following procedure.

First, power off the Command Unit.

Then, while pressing and holding the orange-red configuration button, apply power to the Command Unit. Release the button when the LED turns on and a single-beep is heard.

After the factory reset has been completed, you will need to perform the Fault Detection Configuration procedure (p.21, Section 13) and/or reprogram the controller board.



ATTENTION

You will NOT have to reprogram the individual HON-AOR-CS Call Stations.

4. Does the Command Unit controller board retain its programming if there is complete power loss?

Yes, memory is non-volatile and does not require a backup battery.

5. Are the HON-AOR-CS Call Stations powered by the Command Unit?

Yes, they are line-powered by the Command Unit.

General Troubleshooting

Problem	Possible Causes
<p>The Command Unit does not function at all. It cannot dial out or it cannot be called into.</p>	<ol style="list-style-type: none"> 1. The internal power supply is not properly connected (check primary power and the battery). 2. The cabling for the PSTN/POTS telephone line or analog PBX extension line may not have been properly terminated inside the Command Unit. Verify the internal connections. 3. The cabling for the PSTN/POTS telephone line or analog PBX extension line may have been disconnected. Please verify continuity throughout the cable run. 4. The Command Unit has been damaged by a power surge. Contact Technical Support.
<p>I hear noise on the line.</p>	<ol style="list-style-type: none"> 1. The cabling run for the HON-AOR-CS Call Station may not be twisted, shielded wire. Fluorescent lights, elevator machinery, and other devices can emit noise onto the wire run if they are not twisted and shielded. 2. See Technical Requirements for further details.
<p>The Local Phone rings briefly, but then when I pick up the handset I hear one beep.</p>	<ol style="list-style-type: none"> 1. The HON-AOR-CS Call Station that called in was not programmed with a phone number.
<p>The controller board will not accept the Guard Access Code.</p>	<ol style="list-style-type: none"> 1. You may be remotely programming through a PSTN/POTS telephone line or analog PBX extension line that does not transmit in-band DTMF. Please ensure that in-band DTMF is available. 2. The Guard Access Code has been changed. You can reset the code by first entering the Master Access Code (default is *30*12345678*). <p>Then enter the following command to change the Guard Access Code: * 33 * [0-8 digits] *</p>
<p>On the Command Unit panel, the Station Fault LEDs are illuminated, however the Battery Status and Power Status LEDs are not illuminated.</p>	<p>The ribbon cable connection to the Command Unit controller board is connected in the wrong orientation.</p> <p>Disconnect that controller board side of the ribbon cable, flip that side of the ribbon cable 180-degrees, and reconnect the cable to the controller board.</p>

Servicing

For product service and repair, please contact:

Talkaphone Area of Refuge (AOR) Support

Email: aorsupport@talkaphone.com

Phone: 773.539.1100

Limited Warranty Information

For the latest warranty information, please visit:

<https://www.honeywellareaofrefuge.com/warranty>

System Installation Information Sheet

This installation information sheet has been provided in order to record and safely retain information for future maintenance and operation of this Area of Refuge system.

Area of Refuge System

Installation Address: _____

Installation Date: _____

1. To reach this Command Unit, call this phone number:

2. Phone Number for Off-site Dialing (e.g., Central Station or Monitoring Center):

3. Sub-Command Unit #1 Physical Location:

Sub-Command Unit #2 Physical Location:

4. Termination Location of Telephone Line for Off-site Dialing:

In the event of trouble, please contact the below local service representative.

Name: _____

Company: _____

Address: _____

Phone: _____

Operating Instruction Sheet for the Command Unit

The below operating instruction sheet must be completed and then framed and placed adjacent to the Command Unit for ready reference.

<u>Area of Refuge System</u>		
Model Number:	HON-AOR- _____	Issue Date: _____
OPERATING INSTRUCTIONS:		
1.	ANSWERING A CALL – LIFT HANDSET.	
2.	YELLOW BUTTON – CALL INTO A SPECIFIC STATION. IF THE GREEN LED IS LIT, YOU WILL ANSWER A CALL OR JOIN A CALL IN PROGRESS—ANY OTHER CALLS WILL BE PLACED ON HOLD.	
3.	PLACING STATIONS ON HOLD – PRESS YELLOW STATION BUTTON TO PLACE AN ACTIVE CALL ON HOLD.	
4.	BLUE BUTTON – CALL INTO A SPECIFIC SUB-COMMAND UNIT.	
5.	TERMINATING CALLS – HANG UP HANDSET TO TERMINATE CALLS TO STATION AND SUB-COMMAND UNIT.	
6.	ORANGE BUTTON – DISCONNECTS CALL TO EMERGENCY SERVICES (OFF-SITE ANSWERING POINT). ANY STATION AND SUB-COMMAND UNIT ORIGINALLY ON THE CALL WITH THIS UNIT WILL REMAIN ACTIVE ON THE CALL.	
<u>IMPORTANT NOTE:</u>		
THESE INSTRUCTIONS ARE TO BE FRAMED AND PLACED ADJACENT TO THE COMMAND UNIT FOR READY REFERENCE.		

Operating Instructions for Sub-Command Unit(s) – 5-Stations

The below operating instruction sheet must be completed and then framed and placed adjacent to a Sub-Command Unit for ready reference.

<u>Area of Refuge System</u>		
Model Number:	AOR- _____	Issue Date: _____
OPERATING INSTRUCTIONS:		
1.	ANSWERING A CALL – LIFT HANDSET.	
2.	CALLING A SPECIFIC STATION – LIFT HANDSET—A SINGLE BEEP WILL BE HEARD.	
	ROUTE TO A SPECIFIC STATION BY ENTERING:	
	* 4 + [STATION NUMBER NEXT PHYSICAL LOCATION LABEL BELOW]	
	THERE WILL BE A PAUSE, THEN THE STATION WILL ANSWER WITH AN OPEN CHANNEL (LIVE MIC AND SPEAKER).	
3.	TERMINATING CALLS – HANG UP HANDSET TO TERMINATE CALLS AT THIS SUB-COMMAND UNIT.	
STATION NUMBER	FLOOR	LOCATION NAME
1	_____	_____
2	_____	_____
3	_____	_____
4	_____	_____
5	_____	_____
<u>IMPORTANT NOTE:</u>		
THESE INSTRUCTIONS ARE TO BE FRAMED AND PLACED ADJACENT TO THE COMMAND UNIT FOR READY REFERENCE.		

Operating Instructions for Sub-Command Unit(s) – 10-Stations

The below operating instruction sheet must be completed and then framed and placed adjacent to a Sub-Command Unit for ready reference.

Area of Refuge System

Model Number: **AOR-** _____ **Issue Date:** _____

OPERATING INSTRUCTIONS:

- 1. **ANSWERING A CALL** – LIFT HANDSET.
- 2. **CALLING A SPECIFIC STATION** – LIFT HANDSET—A SINGLE BEEP WILL BE HEARD.

ROUTE TO A SPECIFIC STATION BY ENTERING:

*** 4 + [STATION NUMBER NEXT PHYSICAL LOCATION LABEL BELOW]**

THERE WILL BE A PAUSE, THEN THE STATION WILL ANSWER WITH AN OPEN CHANNEL (LIVE MIC AND SPEAKER).

- 3. **TERMINATING CALLS** – HANG UP HANDSET TO TERMINATE CALLS AT THIS SUB-COMMAND UNIT.

STATION NUMBER	FLOOR	LOCATION NAME
1	_____	_____
2	_____	_____
3	_____	_____
4	_____	_____
5	_____	_____
6	_____	_____
7	_____	_____
8	_____	_____
9	_____	_____
10	_____	_____

IMPORTANT NOTE:

THESE INSTRUCTIONS ARE TO BE FRAMED AND PLACED ADJACENT TO THE COMMAND UNIT FOR READY REFERENCE.

Fault Conditions and Service Contact Instruction Sheet

The below fault conditions and service contact instruction sheet must be completed and then framed and placed adjacent to the Command Unit for ready reference.

Area of Refuge System

Model Number: HON-AOR- _____ **Issue Date:** _____

FAULT CONDITIONS:

- **TEMPORARILY SILENCING THE AUDIBLE FAULT ALARM** – USE THE **FAULT RESET** KEY SWITCH. AN AUDIBLE DOUBLE BEEP WILL BE PROVIDED. IF THE FAULT REMAINS DURING THE NEXT TIMED SUPERVISORY TEST, THE AUDIBLE FAULT ALARM WILL RESUME AGAIN.

LED FAULT INDICATOR(S) WILL REMAIN ACTIVATED UNTIL THE FAULT(S) HAVE BEEN CORRECTED.

- **RESETTING FAULT CONDITIONS AFTER CORRECTIONS** – WHEN THE FAULTS HAVE BEEN CORRECTED AND THE **FAULT RESET** KEY SWITCH USED AFTER THE CORRECTION, AN AUDIBLE DOUBLE BEEP WILL BE PROVIDED, THE AUDIBLE FAULT ALARM WILL SILENCE, AND THE LED FAULT INDICATOR(S) WILL EXTINGUISH.

- **LED FAULT INDICATORS**

OUTSIDE LINE – THERE IS AN OPEN OR SHORT ON THE TELEPHONE LINE—
CHECK CABLING AND CORRECT.

STATION – THERE IS AN OPEN OR SHORT FOR A SPECIFIC CALL STATION—
CHECK CABLING AND CORRECT.

GROUND FAULT – CHECK THE COMMAND UNIT FOR PROPER GROUNDING
AND CORRECT ANY GROUND LOOPS.

BATTERY – BACKUP BATTERY VOLTAGE LEVEL IS LOW – REPLACE BATTERY.

POWER – PRIMARY POWER LOSS HAS OCCURRED

In the event of trouble, please contact the below local service representative.

Name: _____

Company: _____

Address: _____

Phone: _____

IMPORTANT NOTE:

THESE INSTRUCTIONS ARE TO BE FRAMED AND PLACED ADJACENT TO THE COMMAND UNIT FOR READY REFERENCE.

Talk-A-Phone, LLC

7530 N. Natchez Ave.

Niles, IL 60714

773.539.1100

aorsupport@talkaphone.com

www.honeywellareaofrefuge.com

© 2024 Talk-A-Phone, LLC. All rights reserved. Specifications subject to change without notice.

The Honeywell trademark is used under license from Honeywell International Inc.
Honeywell International Inc. makes no representation or warranties with respect to these products.
These products are manufactured by Talk-A-Phone, LLC, Niles, IL 60714, USA.

771-00001 | Rev 1.0 | 05/22/2024

Honeywell