

PEDESTALPRO.COM  
1-800-660-3072

UNLESS OTHERWISE SPECIFIED:

DIMENSIONS ARE IN INCHES  
TOLERANCES:  
FRACTIONAL: ± 1/32  
ANGULAR: ± 2°  
TWO PLACE DECIMAL ± 0.010  
THREE PLACE DECIMAL ± 0.005

INTERPRET GEOMETRIC  
TOLERANCING PER:  
ASME Y14.5 -2009

NAME DATE

DRAWN

CHECKED

PROPRIETARY AND CONFIDENTIAL

THE INFORMATION CONTAINED IN THIS  
DRAWING IS THE SOLE PROPERTY OF  
PEDESTALPRO LLC. ANY REPRODUCTION  
IN PART OR AS A WHOLE WITHOUT THE  
WRITTEN PERMISSION OF PEDESTALPRO LLC  
IS PROHIBITED.

TITLE:

INSTALLATION

Thursday, October 25,  
2018 3:57:46 PM

WEIGHT:

SIZE  
**A**

PART NO.  
22PE1-BUT-03-CRS

REV  
**B**

NO SCALE

SHEET 1 OF 5

| ITEM NO. | PART NUMBER             | DESCRIPTION   | QTY. |
|----------|-------------------------|---|------|
| 1        | 22PE1-BUT-03-CRS        | 2x2 SQ STEEL TUBE   | 1    |
| 2        | PLTBAS-5-2              | 5" STANDARD BASE PLATE  | 1    |
| 3        | PLTCOV-5-2              | 5" STANDARD COVER PLATE   | 1    |
| 4        | --                      | 316 Stainless Steel Ultra-Low-Profile<br>Socket Head Screw 8-32 X 5/16" | 4    |
| 5        | 12IN MONARCH FACE PLATE | BMX 12" MONARCH MOUNTING PLATE  | 1    |
| 6        | --                      | 18-8 Stainless Steel Cap Nut 8-32                                       | 4    |

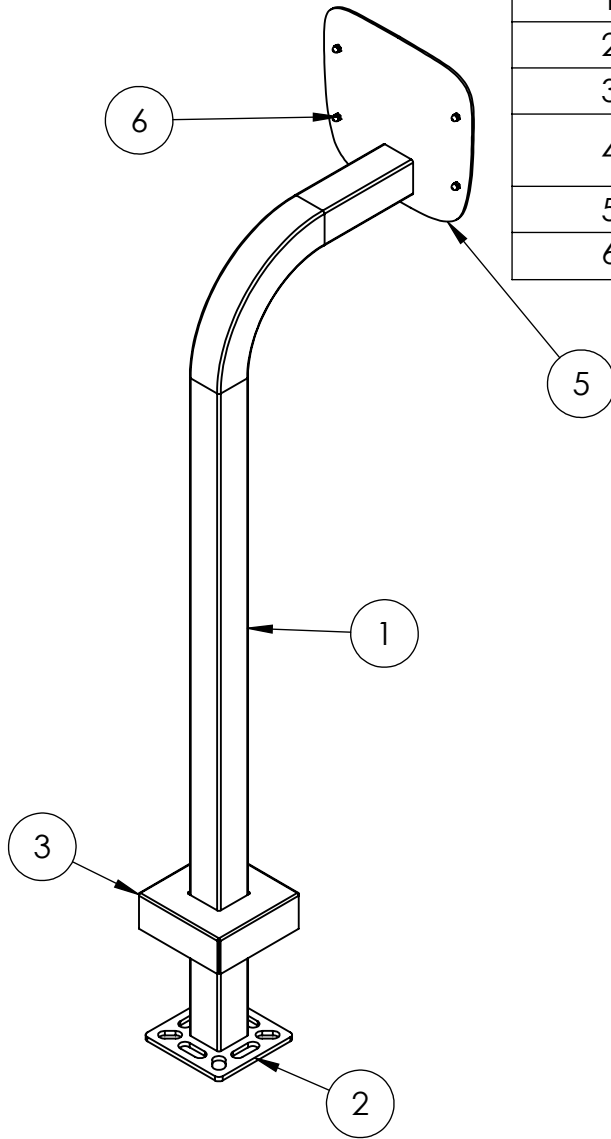

**NOTES:**

1. BUTT WELDED SECTIONS ARE NOT ALLOWED, EACH SECTION OF TUBE MUST BE FROM CONTINUOUS STOCK.
2. ALL WELDS ARE TO BE CONTINUOUS FILLET WELDS UNLESS NOTED OTHERWISE.
3. SEE STANDARD PREPARATION AND COATING INSTRUCTIONS FOR COATING PROCEDURE AND COLOR.
4. FASTENERS ARE TO BE BAGGED AND SHIPPED WITH PEDESTAL.
5. SEE STANDARD PACKAGING INSTUCTIONS FOR PACKAGING PROCEDURE.



PEDESTALPRO.COM  
1-800-660-3072

UNLESS OTHERWISE SPECIFIED:

DIMENSIONS ARE IN INCHES  
TOLERANCES:  
FRACTIONAL  $\pm 1/32$   
ANGULAR:  $\pm 2^\circ$   
TWO PLACE DECIMAL  $\pm 0.010$   
THREE PLACE DECIMAL  $\pm 0.005$

INTERPRET GEOMETRIC  
TOLERANCING PER:  
ASME Y14.5 -2009

| NAME    | DATE |
|---------|------|
| DRAWN   |      |
| CHECKED |      |

**PROPRIETARY AND CONFIDENTIAL**

THE INFORMATION CONTAINED IN THIS DRAWING IS THE SOLE PROPERTY OF PEDESTALPRO LLC. ANY REPRODUCTION IN PART OR AS A WHOLE WITHOUT THE WRITTEN PERMISSION OF PEDESTALPRO LLC IS PROHIBITED.

TITLE:

**ASSEMBLY**

Thursday, October 25,  
2018 3:57:46 PM

WEIGHT:

SIZE  
**A**

PART NO.  
22PE1-BUT-03-CRS

REV  
**B**

NO SCALE

SHEET 2 OF 5