

TAKEX

BATTERY OPERATED PHOTOELECTRIC BEAM SENSOR

TXF-125E-KH : OUTDOOR 100m (330ft)

Instruction Manual

Thank you for purchasing this product. Before using the product, please read this instruction manual to ensure correct operation. This product is designed to be installed into the housing (sold separately) for use. Make sure to install this product into the housing for use.

This unit is a battery operated photoelectric beam sensor consisting of a transmitter and a receiver.

The direct path between the transmitter and the receiver forms the detection line. When this detection line is interrupted (light is obstructed for 0.05 to 0.5sec. or more), the receiver outputs a signal.

The battery operated design allows this unit to operate without an external power supply over a long period of time. The battery power also can be shared with a wireless transmitter.

In order to ensure that the detection line has sufficient margin of sensitivity, adjust the direction of the light beams before putting the system into operation. Providing sufficient margin of sensitivity reduces the malfunction caused by dense fog, heavy rain, frost, snow, and other such weather conditions.

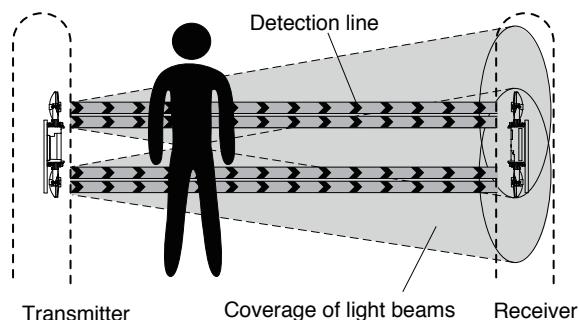

Main Features

(1) WIDE BEAM



As is the case with the wired system, increasing the vertical beam pitch together with the 4 beam simultaneous interruption system significantly reduces false alarms from birds or fallen leaves, etc.

(2) QUAD HIGH POWER BEAM



The beam power is 100 times greater than the minimum requirement. The beam distance is 10 times longer than the described specification. This high power beam ensures high reliability against harsh conditions such as fog, snow and heavy rain.

(3) REDUCE COSTS



By combining a wireless transmitter, external wiring becomes unnecessary, which can substantially reduce wiring material costs and related work. In addition, this unit realizes longer battery life due to its low current consumption.

(4) DETECTION DISTANCE SELECTABLE



4 detection distances are selectable within a single unit [100m(330') / 75m(247') / 50m(165') / 25m(82')]]

(5) BATTERY SHARING FUNCTION



This function integrated in the sensor enables battery sharing with a wireless transmitter. Low battery output voltage is adjustable by volume switch.

(6) ECOLOGY



Environment friendly. RoHS compliant. (2011/65/EU+(EU)2015/863)

(7) DUAL RING SIGHT



Enables clear view for easy beam alignment.

(8) TARGET COLOR



The vivid color of the internal structure can be recognized easily at distance during the beam alignment procedure. The color differs between transmitter and receiver for easy installation and checking.

(9) INCREASED ANGLE ADJUSTMENT



$\pm 20^\circ$ vertical adjustment to adapt to changes in elevation for maximum flexibility <Reference> This unit can be installed in a place with a height difference of 18m(59') or less when the protection distance is 50m(165'), and 36m(118') or less when it is 100m(330').

(10) WIRELESS ALIGNMENT CHECKER



Enables easy and accurate beam alignment. (Sold separately)

(11) LIGHTNING PROTECTION



This unit is insusceptible to induced lightning because of its battery operated system.

— TABLE OF CONTENTS —

1 PARTS DESCRIPTION	4 INSTALLATION METHOD	9
(1) MAIN UNIT	ATTACHING TO THE TOWER	9
(2) ACCESSORIES	5 OPTICAL AXIS ADJUSTMENT	10
(3) NAMES OF OPERATION SECTION	(1) NAMES AND FUNCTIONS	10
(4) NAMES OF TERMINAL SECTION	(2) ALIGNMENT MECHANISM	11
2 PRECAUTIONS	(3) SOUND CHECK	13
3 BEFORE USE	(4) MONITOR OUTPUT VOLTAGE	14
(1) CHECKING SPACE FOR WIRELESS TRANSMITTER	(5) WIRELESS ALIGNMENT CHECKER	15
(2) ABOUT BATTERIES	6 OPERATION CHECK	15
(3) MOUNTING WIRELESS TRANSMITTER	7 SENSOR FUNCTIONS	16
(4) WIRELESS TRANSMITTER WIRING	8 TROUBLESHOOTING	18
(5) SETTING LOW BATTERY OUTPUT VOLTAGE	9 SPECIFICATIONS	19
(6) MOUNTING BATTERIES	10 EXTERNAL DIMENSIONS	20

1 PARTS DESCRIPTION

This section describes the contents of the product package and the names and functions of the parts that appear in this instruction manual. Check that the following transmitter, receiver, and accessories are included in the box when you first unpack the product.

(1) MAIN UNIT

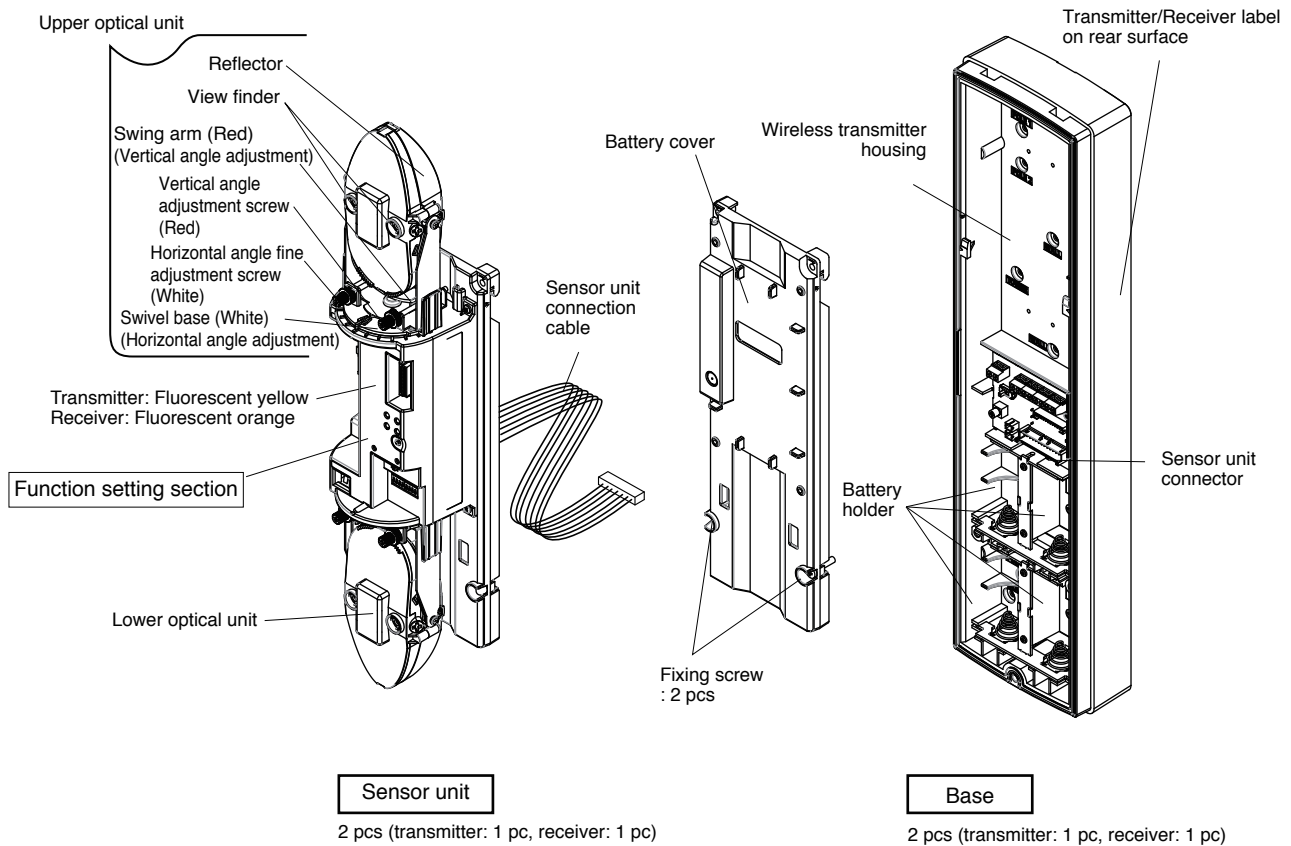

(2) ACCESSORIES

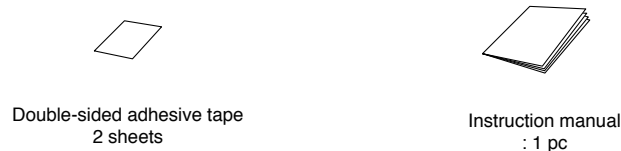

(3) NAMES OF OPERATION SECTION

[Transmitter]

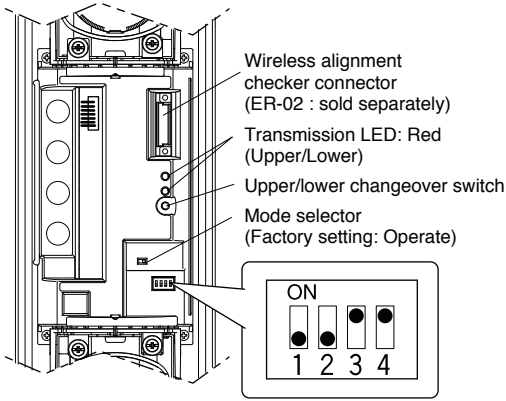

- ① ② Transmission channel changeover switch (Factory setting: 1CH)
- ③ ④ Protection distance changeover switch (Factory setting: 100m (330'))

[Receiver]

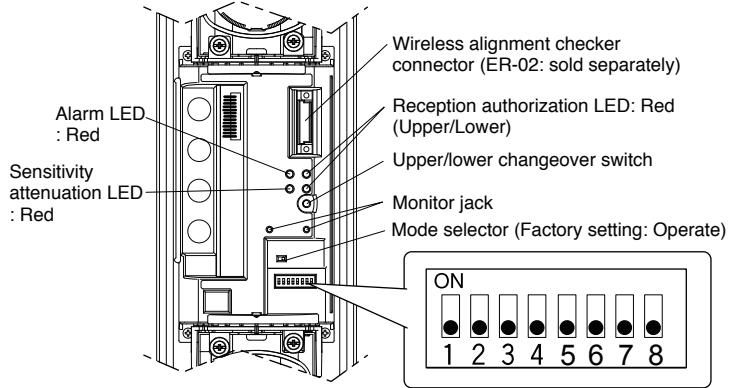

- ① ② Beam channel changeover switch (Factory setting: 1CH)
- ③ ④ Detection response time changeover switch (Factory setting: 50ms (0.05sec.))
- ⑤ Battery saving function switch (Factory setting: OFF)
- ⑥ Repeat output function switch (Factory setting: OFF)
- ⑦ Sound check switch (Factory setting: OFF)
- ⑧ Not used

For each switch functions, refer to "7. SENSOR FUNCTIONS".

(4) NAMES OF TERMINAL SECTION

[Transmitter]

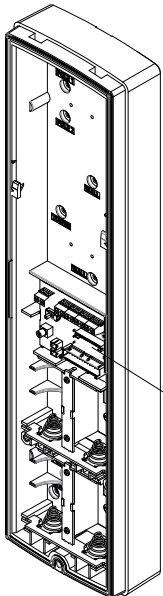

Test switch of low battery to a wireless transmitter
Adjustment volume of power supply voltage to a wireless transmitter when the battery level is low

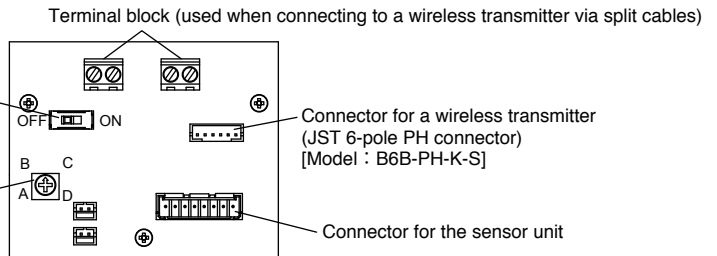

[Receiver]

Test switch of low battery to a wireless transmitter
Adjustment volume of power supply voltage to a wireless transmitter when the battery level is low

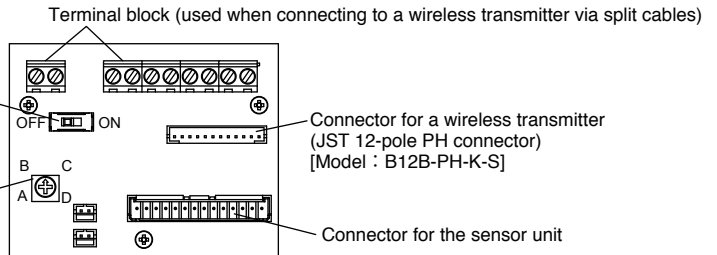

2 PRECAUTIONS

Be sure to observe

This manual describes precautions by classifying them based on degrees of danger and damage that would be generated if using the unit incorrectly.



Warning

This indicates the possibility of severe injury, and even death, if ignored or a user handles the unit incorrectly.



Caution

This indicates the possibility of minor injury and/or damage to properties, or of a notification delay in your system due to false operations and/or non-detection, if ignored or a user handles the unit incorrectly.

● We categorize these precautions throughout the manual using the following symbols.



A prohibited action, you must not do.



An action you must do, and information you should keep in mind



Warning



Do not disassemble or modify this device. This may cause a fire, electrical shock, or malfunction of the device.



If the following events occur, turn off the power of the unit immediately, and ask the place of purchase for repair. Failure to follow this may result in fire, electric shock, and/or malfunction.

- Smoke, abnormal odor, and/or sound are found
- Liquid, such as water, and/or foreign material has entered the unit
- The unit has deformed and/or damaged parts



Do not install this device in a location that cannot support its weight. This may cause the device to fall and cause an injury or malfunction of the device.



Use batteries correctly. Failure to follow this may result in burns, injury, fire, and/or pollution in the surroundings due to burst, heat generation, and/or liquid spill of batteries.

- Do not charge batteries.
- Do not heat, disassemble, and/or put them into fire or water.
- Do not use new and old batteries together.
- Do not contact metal on the positive and negative ends. Do not carry or store them with metal.
- Be sure to use the specified batteries, and check that the polarity is correct when connecting.





Medical equipment may be subject to influence from the unit, if you use it nearby. In such cases, avoid using the unit. Or, before using, perform a sufficient operation check and confirm there is no influence.

⚠ Caution

 Do not apply impact to the unit. Strong impact may result in performance deterioration and/or damage to the unit.

 The unit may not operate properly near devices that generate a strong electric or magnetic field. Also, devices near the unit may not operate properly due to the magnetic field and/or magnetism generated from the unit. Make sure to confirm before operation.

 Make sure to perform a sufficient operation check on the whole system before operation.

 Do not use the transmitter and receiver of different model numbers together. Failure to follow this could result in false and/or non-detection.

 Do not use models other than this series (TXF-125E) on the extension of the same detection line. Failure to follow this could result in false and/or non-detection due to interference between the sensors.

 Installing the unit in the following places may result in false and/or non-detection.

- Places shielded by trees
- Places where there are light reflecting objects on the ground on the optical axis
- Places where moving objects (such as laundry) shield the light in the optical axis
- Places that are unstable and prone to vibration
- Uneven places
- Places subject to polluted water, seawater, and/or chemicals
- Places where small animals may pass, such as directly above fences
- Places close to fences
- Inclined or horizontal installation

 When branches, leaves of trees and weeds around the detection line blow in the wind, they may interrupt the detection line and result in false detection. Periodically trim (cut) branches leaves, and weeds.

 Vine plants may entwine the unit when growing, which may result in false detection. Periodically trim them.

 For multi-level protection, use the upper and lower sensors with the same rated protection distance, and set the same frequency channel for both sensors. Failure to follow this could result in false and/or non-detection.

 Do not install the unit in places subject to oil smoke, steam, high humidity, and/or a lot of dust. Electricity that travels through these substances may result in fire, electric shock, and/or false operation.

 Securely conduct installation work according to the instruction manual. Also, make sure to use the supplied accessories and specified components. Failure to follow this may result in injury and/or property damage in the event of fire, electric shock or fall of the unit.

 Install the unit straight so that it does not look inclined from the front.

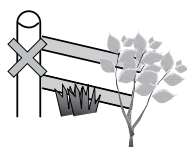

• Installation in locations shaded by trees etc.

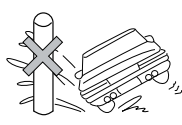

• Installation in locations where the device may be splashed by dirty water or direct sea spray.

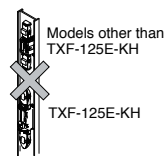

• Using TXF-125E-KH together with other models

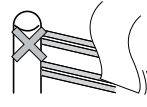

• Installation in areas where moving objects (the laundry etc) can obstruct the optical axis

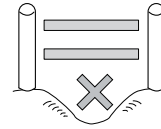

• Installation on uneven ground



• Installation in an unstable, wobbling location

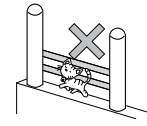

• Installation directly above a wall

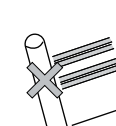

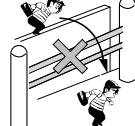

• Slanted installation





• Installation close to a wall

 Avoid mounting, battery connection, and battery replacement where humidity is high. Humidity may enter the unit and generates condensation, which could result in malfunction.

 Do not touch connector sections and batteries with wet hands, which could result in electric shock and/or corrosion.

 Make sure that batteries are not heated, when removing them.

 Use the lithium-metal primary batteries for this unit. Handle them as dangerous goods for transport by air, observing the IATA Dangerous Goods Regulations in terms of packing, marking and labeling.

 When disposing batteries, observe regulations in force of each country.

 For replacement of batteries, use the batteries specified in the instruction manual. If you use different batteries, specified performance will not be met.

 The battery life is just a reference when used at the normal temperature, and it is not the guaranteed value.

 Before actual installation, perform a sufficient operation check in a place of operation and confirm that the receiver can clearly receive the beams.

 Installing the unit in location where direct sunlight, headlight of vehicle, IR illumination or LED light directly enter the optical axis may result in false and / or non-detection.

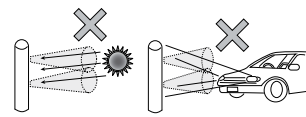

Installation in location where strong light such as sunlight or light from vehicle headlights can directly enter the optical axis.

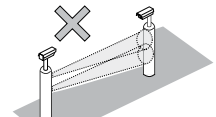

Installing IR illumination overlapping detection line of beam sensor.

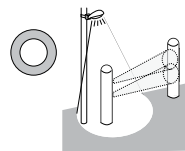

Installation so that the LED light does not enter into the optical axis of beam sensor.

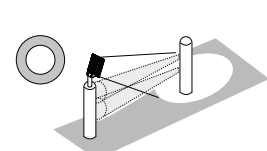

Installation so that the LED light illuminates transmitter side, where LED light is required.

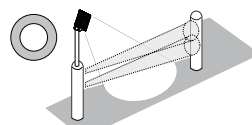

Installing the LED light so that it looks down from high mounted position, separated from the optical axis of receiver where LED lights in parallel with detection line.

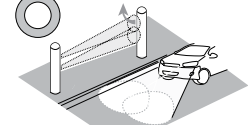

Installation so that the optical axis (Receiver) is adjusted toward an opposite direction of road, when detection line is set in parallel with road.

Cautions when using the outdoor photoelectric beam sensor (Regular maintenance)

- In areas where there are trees or weeds, the photoelectric beams may become obstructed by overgrown branches or leaves. As this may cause false detection, be sure to trim down leaves and branches according to the growth of the plants. Furthermore, the photoelectric beams may get obstructed by swaying branches or leaves due to wind.
- Vine plants may wrap around the photoelectric beam sensors causing false detections. Therefore, be sure to prune such plants regularly.
- Insects, bird droppings, or other natural phenomena may also soil the sensors causing false detection. Be sure to clean the sensors regularly.

PROTECTION DISTANCE AND LIGHT BEAM COVERAGE

As the infrared light leaves the transmitter, it expands into conical shaped light beams. The optical axis is in the center of the light beams. Adjust the reflector so that the device on the opposite side is in the center of the light beams.



If the optical axis (center of the light beams) is aligned correctly, a detection line with sufficient margin of sensitivity is formed.



If the optical axis is not aligned correctly, there will be insufficient margin of sensitivity even if the receiver is at the center of the light beams, making the system more susceptible to adverse effects of the environment resulting in a malfunction.

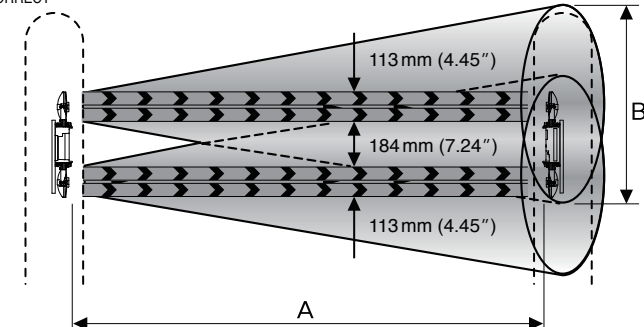

A: Protection Distance	B: Light Beam Coverage
50 m (165')	Approx. 1.2 m (4')
100 m (330')	Approx. 2.4 m (8')

MOUNTING HEIGHT

As these sensors are designed to detect humans, adjust the center of the sensors to the height of approximately 0.8 m (2.6ft) from the ground when installing both on a wall and on a pole.

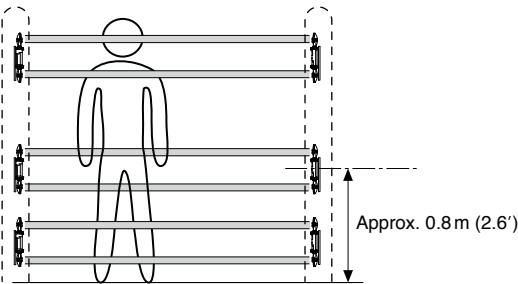

Installing by adjusting the center of the sensor to approximately 0.8 m (2.6ft) from the ground i.e. the protection line is at waist height for humans, for reliable detection.



If the installation position is too high or too low, making protection line above shoulder height or below knee height, detection becomes less reliable.

OPTICAL AXIS ADJUSTMENT RANGE

Refer to the diagram below, and install the sensors within the optical axis adjustment range. (Photoelectric beams are shown in simplified form)

Top View

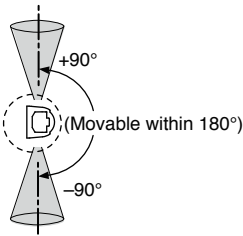

Side View

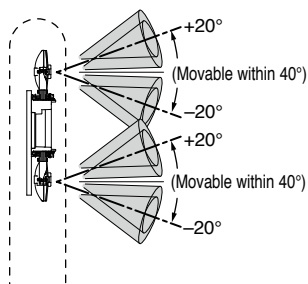

Caution

The optical axis may be shielded depending on the shape of the housing and mounting surface. Check the optical axis range carefully and start installation before use.

Range where the optical axis is shielded

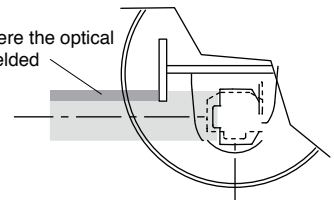

(Example 1)

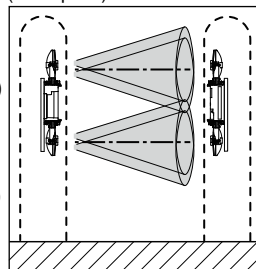

(Example 2)

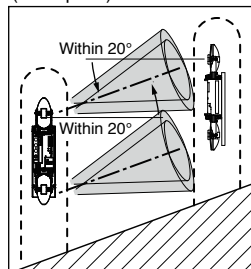

(Example 3)

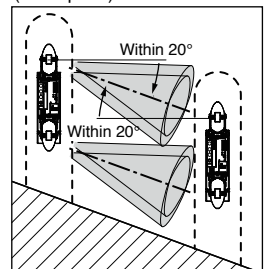

EXAMPLE OF PRACTICAL APPLICATION

In order to minimize the occurrence of malfunctions, refer to the protection diagram below for optimal operation. Using the sensors incorrectly may cause malfunction. (Light beams are shown in simplified form)



- Mutual interference or wraparound of the photoelectric beams can be prevented by changing the channels. Refer to "7 SENSOR FUNCTIONS"
- Set corresponding transmitters and receivers to the same channel.
- Do not use other series together (for example, PXB series with double modulation type). This unit may receive interference, and detection may fail.

- When using multi-level protection or installing straight line protection with multiple spans, use a sensor with selectable modulation frequency. In addition, select an appropriate channel and install the transmitter and the receiver in appropriate locations, according to the following examples. Incorrect channel selection may cause malfunction.
- In case of multi-level protection, set modulation frequency channel for upper and lower sensors to the channels at intervals, such as "1" and "3", or "2" and "4".

● Straight Line Protection

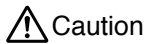
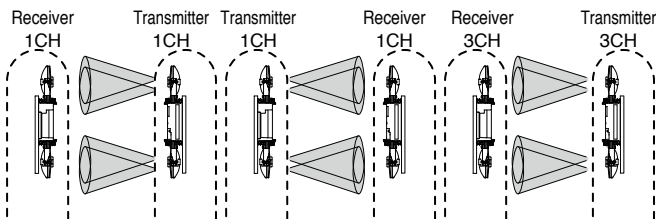

For straight line protection, set the frequency of 2 adjacent sensors to the channels at intervals and provide up to 4 spans. Also, perform a sufficient operation check before actual operation. Failure to follow this may result in false detection due to wraparound.

● 2 Level Protection

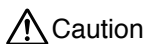
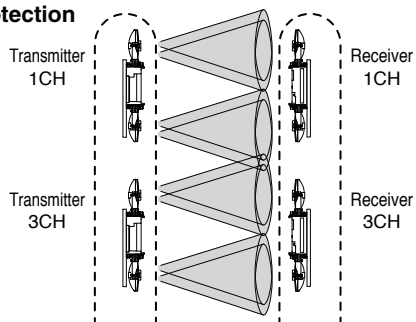

For 2 level straight line protection, set the frequency of 2 adjacent sensors to the channels at intervals and perform a sufficient operation check before actual operation. Also, set the same photo-transmitting power (distance setting) in the upper and lower sensors. Failure to follow this may result in false detection due to wraparound.

● 2 Level Straight Line Protection

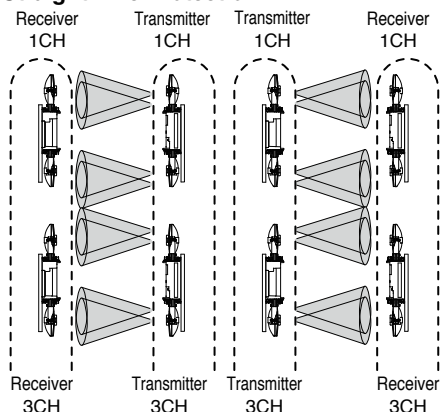

For 2 level straight line protection, set the frequency of 2 adjacent sensors to the channels at intervals and provide up to 2 spans. Also, perform a sufficient operation check before actual operation. Failure to follow this may result in false detection due to wraparound.

● External Perimeter Protection

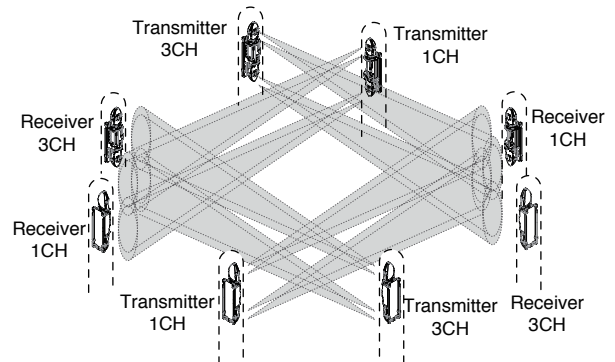

● 2 Level External Perimeter Protection

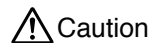
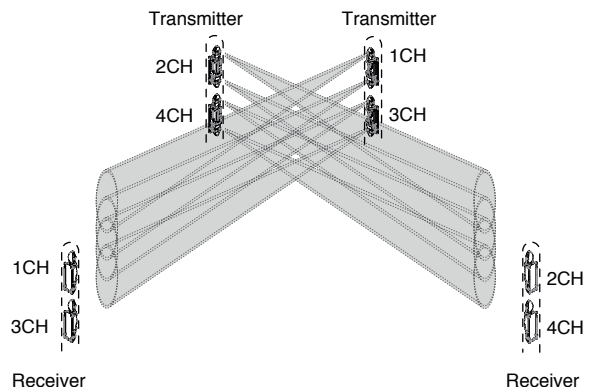

For 2 level external perimeter protection, install receivers by keeping one away from another, and perform a sufficient operation check before actual operation. Failure to follow this could result in false detection due to wraparound.



- For the installation methods not described in the instruction manual (installation of straight line protection with 4-span or more, 3 level protection or more, or others), contact the place of purchase or TAKEX.
- Consult with TAKEX distributor or TAKEX regional office about the frequency selection for installations not mentioned in this instruction manual. Inappropriate choice of frequency may cause malfunction.

3 BEFORE USE

(1) CHECKING SPACE FOR WIRELESS TRANSMITTER

- The space accommodates a wireless transmitter.
- Please consider the dimensions of the wireless transmitter unit and the necessary wiring prior to installation.

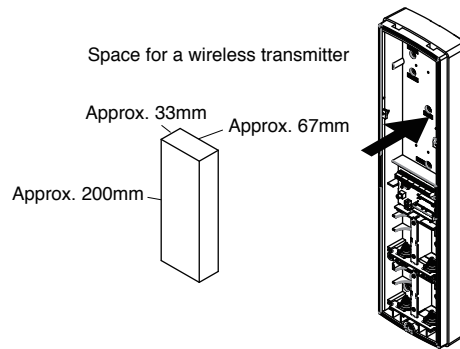

(2) ABOUT BATTERIES

- The recommended battery is SAFT LS33600 (3.6VDC).
- The battery life is approximately 5 years if 2 batteries (recommended) are used. (when the unit performs detection 100 times a day, excluding wireless transmitter)
- Note that when batteries other than those recommended are used, the unit may not operate correctly.

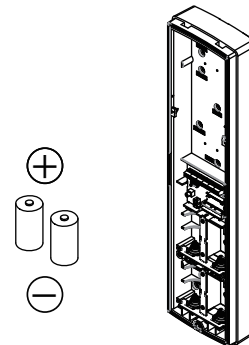

(3) MOUNTING WIRELESS TRANSMITTER

- Attach the supplied double-sided adhesive tape to the wireless transmitter, and fix it in the space of the base.
- Depending on the wireless transmitter fixing location, pole or wall mounting holes may be hidden. In such cases, fix the wireless transmitter after mounting the base.
- For a wireless transmitter to be mounted, check operation and configure settings according to instruction manual of the wireless transmitter.

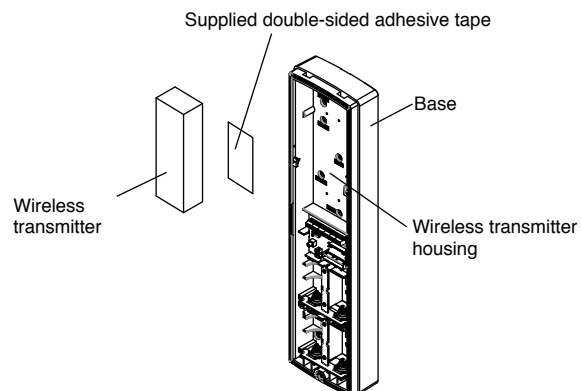

(4) WIRELESS TRANSMITTER WIRING

The wireless transmitter can be wired in two ways, using the terminal block or connector. For wiring using the connector, prepare a connector harness separately.

[Transmitter]

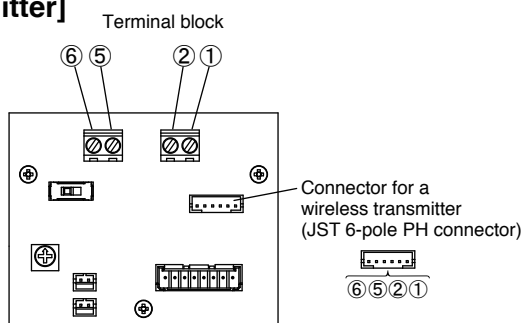

Terminal block

LOW BATTERY OUTPUT		
①	N.C.	Contact method: Dry contact relay (N.C)
②	COM	Contact capacity: 30V DC 0.1A (resistive load)
POWER OUTPUT		
⑤	+	3.0V DC 65mA MAX
⑥	-	

[Receiver]

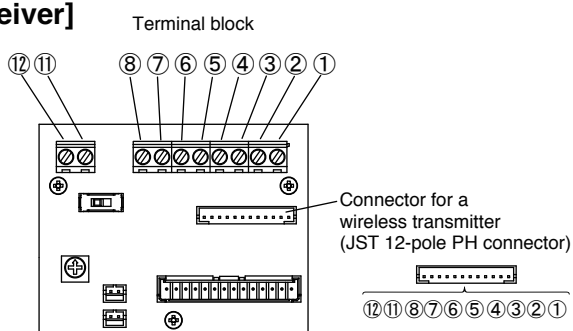

Terminal block

ALARM OUTPUT		
①	N.C.	Contact method: Dry contact relay output form C Contact capacity: 30V DC 0.1A (resistive load)
②	COM	
③	N.O.	
ENVIRONMENT OUTPUT		
④	N.C.	Contact method: Dry contact relay output form C Contact capacity: 30V DC 0.1A (resistive load)
⑤	COM	
⑥	N.O.	
LOW BATTERY OUTPUT		
⑦	N.C.	Contact method: Dry contact relay (N.C.) Contact capacity: 30V DC 0.1A (resistive load)
⑧	COM	
POWER OUTPUT		
⑪	+	3.0V DC 65mA MAX
⑫	-	

(5) SETTING LOW BATTERY OUTPUT VOLTAGE

When sharing the battery power with a wireless transmitter, check and adjust the low battery output voltage level for the wireless transmitter. Refer to the "MOUNTING BATTERIES" section, and mount batteries.

Warning

 When sharing the battery power of TXF-125E-KH with a wireless transmitter, don't insert batteries into the wireless transmitter. Failure to follow this may result in fire or explosion.

 Wireless transmitter is not incorporated into this unit at the time of shipment from the manufacturer. There is a possibility that the operation of beam sensor becomes unstable depending on the wireless transmitter to use.

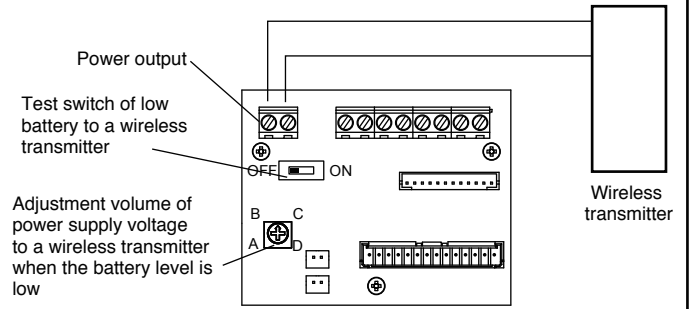

*The figure shows the terminal section on the receiver.

- ① Check the specifications of the wireless transmitter first. Refer to the table on the right for low battery voltage, and set the power supply voltage adjustment volume to an appropriate value.
- ② Turn the low battery test switch ON, and check if low battery signal is output from the wireless transmitter.
- ③ After checking, be sure to turn the test switch OFF.

Reference for the low battery voltage

A	Approx. 2.0V
B	Approx. 2.1V
C	Approx. 2.2V
D	Approx. 2.3V

OFF  ON

(6) MOUNTING BATTERIES

Mount batteries in the battery holder of the base.

- *Max, 4 batteries can be accommodated in battery holder.
- *Use 2 or more batteries.
- *Using 4 batteries allows for longer battery life.
- *Batteries can be mounted in any position. However, it is recommended to accommodate the batteries on the upper side of the battery holder when two batteries are used in order to make the space open to the screw fixing holes for wall or pole mounting on the lower side.

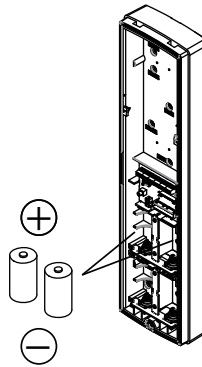

 Be sure to place the positive end of batteries on the top as in the figure.

4 INSTALLATION METHOD

1

Sensor unit

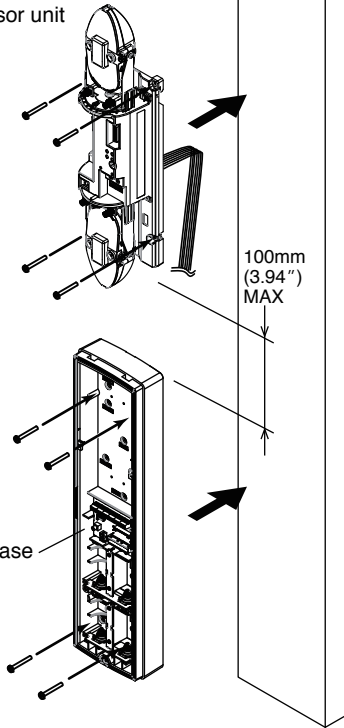

100mm
(3.94")
MAX

Base

- ① Break appropriate knockouts for the mounting holes of the base unit using a screwdriver.
- ② Attach the sensor and base units to the housing base using tapping screws.

2

Connection cable

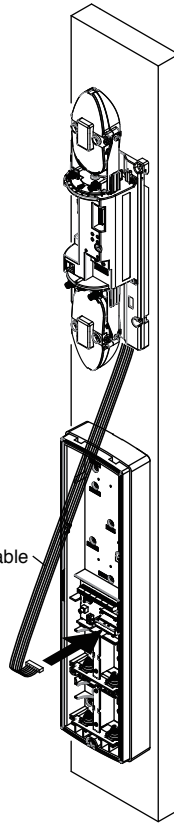

- ① Mount a wireless transmitter to a wireless transmitter space. Arrange wiring and configure settings according to the wireless transmitter instruction manual.
- ② Connect the connection cable of the sensor unit to the base unit.

3

Wireless transmitter housing

Battery cover

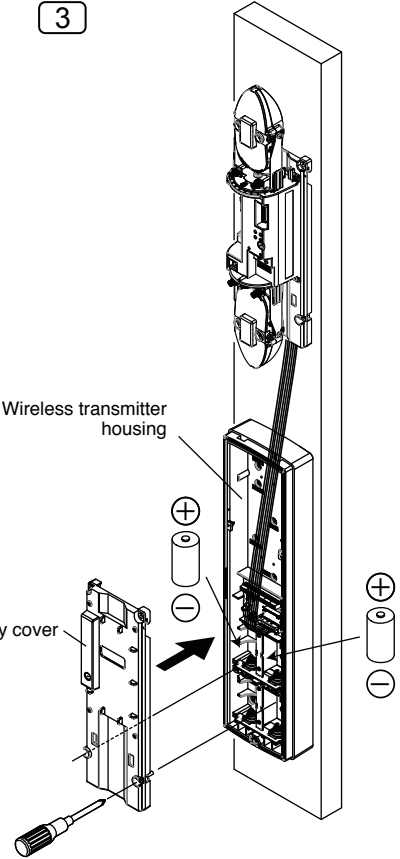

- ① Mount batteries in the battery space on the base. (Refer to the "3 (7) MOUNTING BATTERIES" section)
- ② Attach the battery cover.

ATTACHING TO THE TOWER

1

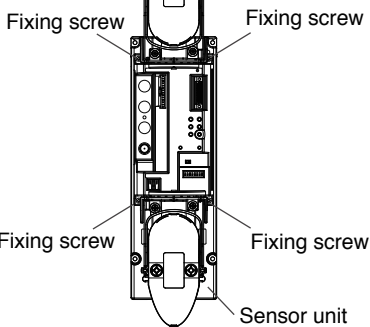

Remove 4 × fixing screws on the sensor unit

2

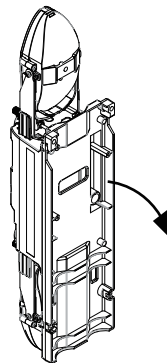

Remove the mounting plate fixed on the sensor unit

3

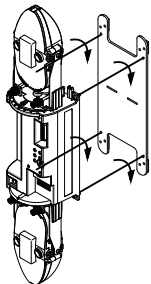

Fix the TAKH BRACKET to the sensor unit with 4 × attached screws

4

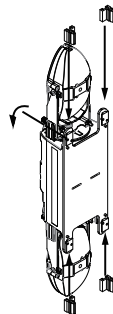

Slide 4 × attached fixing piece into the TAKH BRACKET and lightly fix with attached screws

5

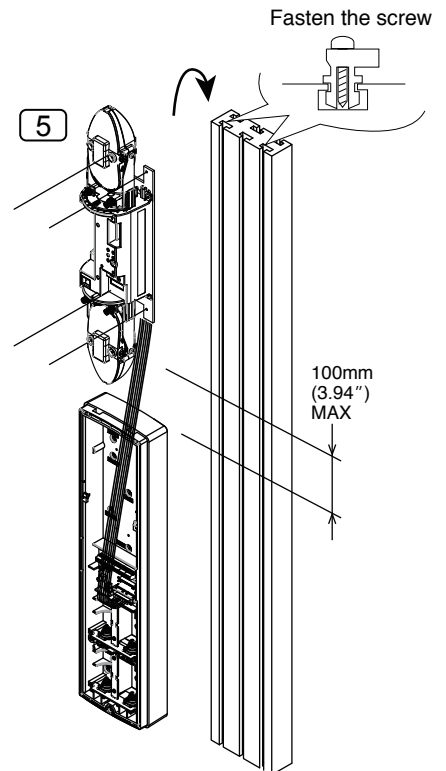

Fasten the screw

100mm
(3.94")
MAX

Slide the sensor unit with TAKH BRACKET from top of the beam tower spine and fasten screws

5 OPTICAL AXIS ADJUSTMENT

By aligning the optical axis correctly, a protection line with sufficient margin of sensitivity can be created, reducing the occurrence of malfunction. Always adjust the optical axis on both upper and lower levels.



Adjusting the optical axis correctly ensures a sufficient sensitivity margin that increases resistance to dense fog, snow, and heavy rain, establishing a highly reliable intrusion alarm system.

(1) NAMES AND FUNCTIONS

● Names of the Optical Unit

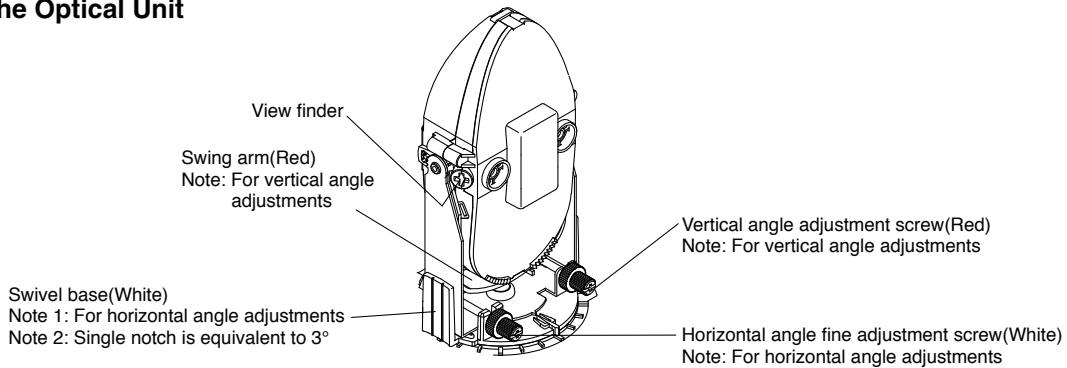

● Reflector Section Horizontal/Vertical Angle Adjustment Method

Horizontal

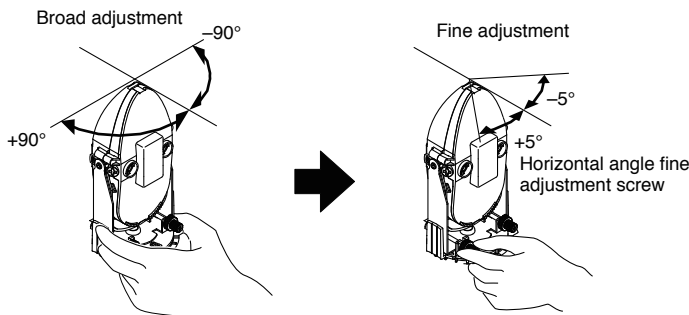

Broad adjustment can be made by moving the swivel base within the range of 0° to ±90°.

Next, fine adjustment of 0° to ±5° can be made using the horizontal angle adjustment screw.

Vertical

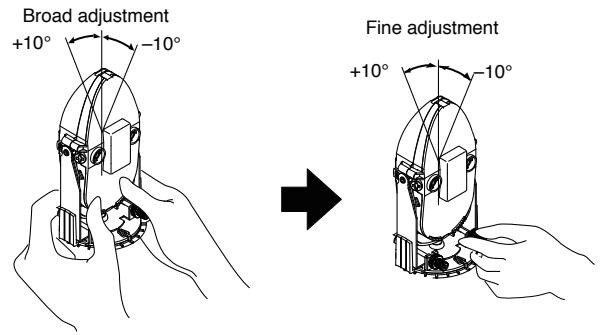

The inclination of the reflector can be adjustable between -10° and +10° by pushing it forwards or backwards.

Next, fine adjustments of 0° to ±10° can be made using the vertical angle adjustment screw.

● Double Ring Alignment Mechanism, visible from the view finder

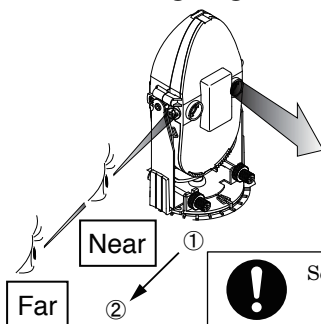

Near When looking at the view finder closely, the view appears as the diagram on the right. Adjust the angle so that the target color appears in the center of the ring.

Far When looking at the view finder from a distance, the view appears as the diagram on the right. Adjust the angle so that the target color appears in the center of the ring.

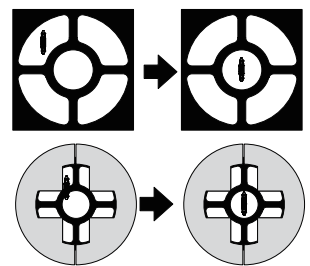

(High accuracy)

! Sequence of adjustment ①→②

(2) ALIGNMENT MECHANISM

- 1 Move the swivel base and swing arm so that the opposite device is roughly aligned with the view finder.

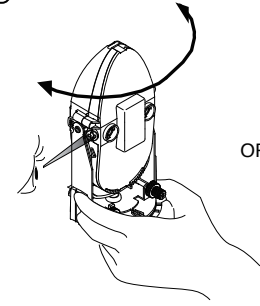

Horizontal angle adjustment

OR

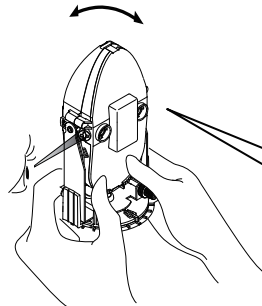

Vertical angle adjustment

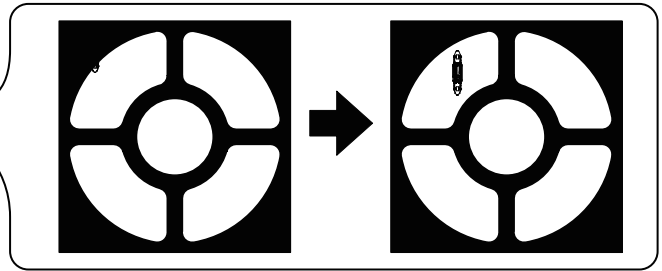

- 2 Look closely through the view finder, and adjust the position so that the sensor of the opposite device is visible at the center of the ring using the horizontal and vertical angle fine adjustment screws.

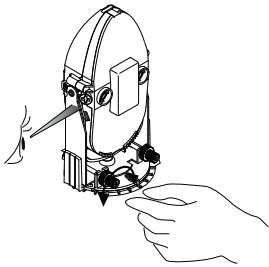

Horizontal angle fine adjustment

OR

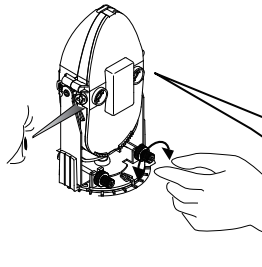

Vertical angle adjustment

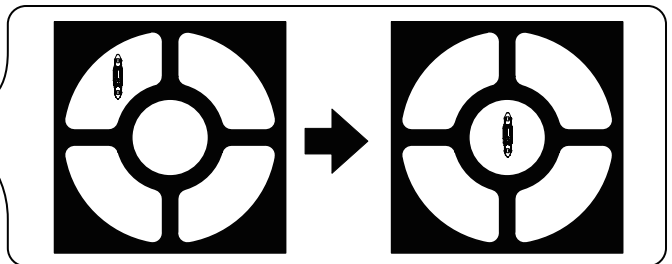

- 3 Look through the view finder from a distance, and readjust so that the sensor of the opposite device is visible at the center of the ring using the horizontal and vertical angle fine adjustment screws.

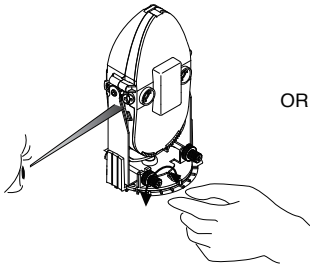

Horizontal angle fine adjustment

OR

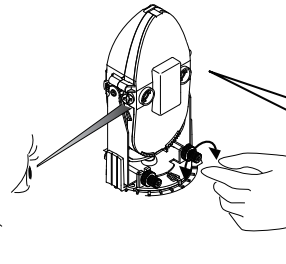

Vertical angle adjustment

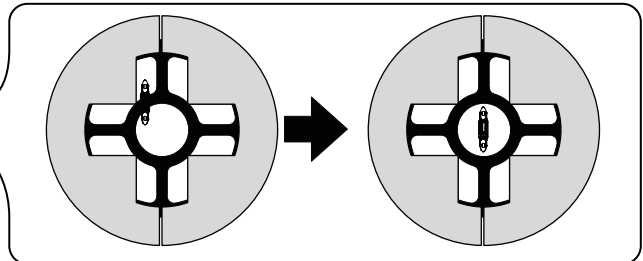

- 4 Turn on the power to the transmitter and receiver. When adjusting beam alignment, please select "Mode selector" to "Alignment" check that the LEDs of both the transmitter and receiver units are lit.

Names of operation section

Note: This section describes the name and function of each part used during optical axis adjustment.

Alarm LED
Note: Only available on the receiver
• Lights up when an alarm is output.

Sensitivity attenuation LED
Note: Only available on the receiver
• Lights up when the sensitivity is insufficient.

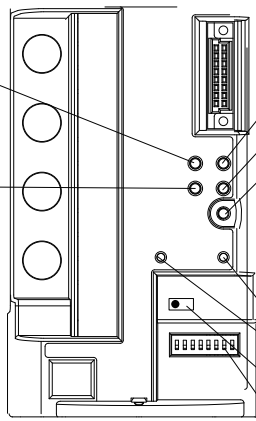

Upper transmission LED/reception authorization LED
Lower transmission LED/reception authorization LED
Upper/lower changeover switch

The corresponding LED lights up when the transmission/reception is authorized. (Upper and/or lower can be switched by the upper/lower changeover switch.)

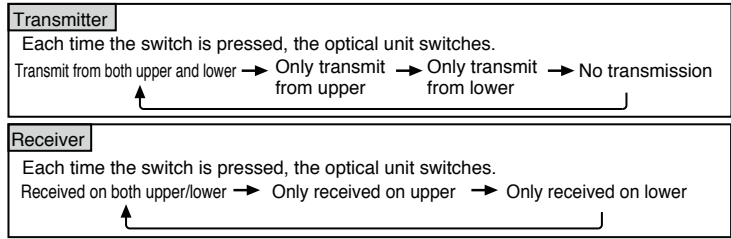

Monitor jack Note: Only available on the receiver
• The monitor output voltage can be checked by using a commercially available tester.

Mode Selector : When adjustment, set "Alignment", When operation, set "Operation".



When adjusting beam alignment, please select "Mode selector" to "Alignment" on both the transmitter and the receiver in order to adjust the beam alignment accurately.

Sound check switch Note: Only available on the receiver
• Beam reception level can be checked by the sound tone.
In the walk test mode, the beep sound is generated according to the alarm output.

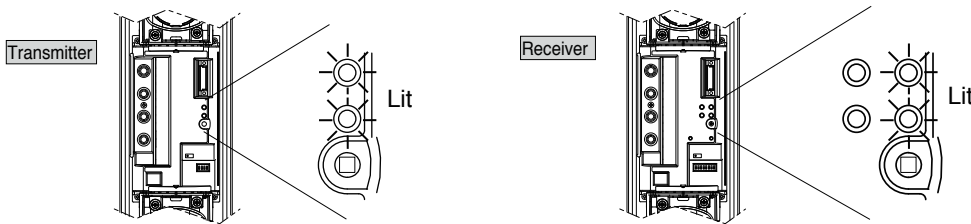

- 5 Check the status of the alarm LED and sensitivity attenuation LED on the receiver. Refer to the table below, and take an appropriate measurement.

	LED status	Description of the Display	Remedy
Receiver	<ul style="list-style-type: none"> • Upper/lower transmission/reception authorization LED: Lit • Alarm LED: Off • Sensitivity attenuation LED: Off 	① The optical axis adjustment has been almost aligned.	① Go to step 6 and fine adjust the optical axis (Adjust the upper and lower levels individually again)
	<ul style="list-style-type: none"> • Upper/lower transmission/reception authorization LED: Lit • Alarm LED: Lit • Sensitivity attenuation LED: Off 	① Different channels are set for the transmitter and receiver ② Interference between the photoelectric beams	① Set the same channel for the transmitter and receiver ② Change to a channel that is not influenced by other factors
	<ul style="list-style-type: none"> • Upper/lower transmission/reception authorization LED: Lit • Alarm LED: Off • Sensitivity attenuation LED: Lit 	① The light enters the receiver, but the light reception level is insufficient (The optical axis is misaligned) ② The protection distance setting is not appropriate	① Go to step 6 and fine adjust the optical axis (Adjust the upper and lower levels individually again) ② Set the appropriate protection distance
	<ul style="list-style-type: none"> • Upper/lower transmission/reception authorization LED: Lit • Alarm LED: Lit • Sensitivity attenuation LED: Lit 	① The light does not enter the receiver at all (The optical axis is not adjusted correctly)	① Go back to step 1 and adjust the optical axis again

- 6 Adjust the optical axis in order to realize higher accuracy. Be sure to perform using one of the following methods.

- "Optical Axis Fine Adjustment Using the Sound Check"
: The sound check function is used to describe the light reception level using high and low pitch tones.
- "Optical Axis Fine Adjustment Using the Monitor Output Voltage"
: Checking the light reception level value using the monitor output voltage will ensure greater accuracy during optical axis adjustment.
- "Optical Axis Fine Adjustment Using the Wireless Alignment Checker"
: Checking the light reception level value using the alignment voltage will ensure greater accuracy during optical axis adjustment.
: The light reception level value can also be monitored from the transmitter.
: For more details on how to operate the wireless alignment checker, refer to the ER-02 instruction manual.

(3) SOUND CHECK

The sound check function indicates the light reception level by using high and low pitched tones.
The sound check function is only installed on the receiver.



First, check only the transmission and reception on the upper level, and then check only the transmission and reception on the lower level.
(When the light can be received on both the upper and lower levels, the beep sound is generated at the total light reception level of the upper and lower levels.)

- 1 Turn the sound check switch on the receiver to the ON position.
When the optical axis is roughly aligned, the beep sound is made.
The optical axis is incorrectly aligned if no sound is made.

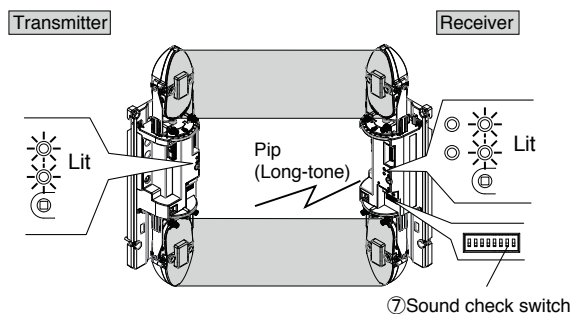
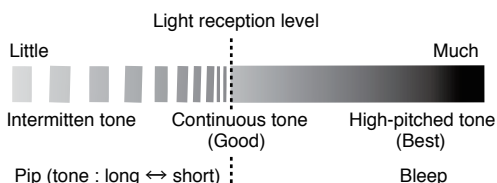

- 2 Fine adjust optical axis of the upper level.

- 1 Press the upper/lower changeover switch on the transmitter to select [Only transmit from upper].
- 2 Press the upper/lower changeover switch on the receiver to select [Reception authorization on upper only].
- 3 Turn the adjustment screw to fine adjust until the tone reaches the highest pitch.
(Adjust both the transmitter and receiver.)

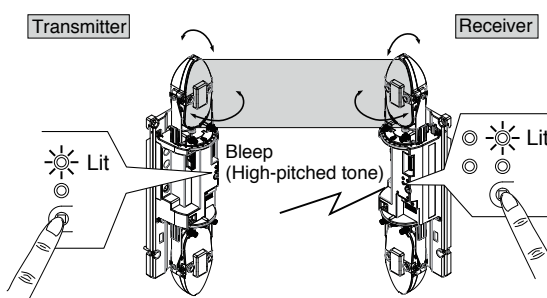

- 3 Fine adjust optical axis of the lower level.

- 1 Press the upper/lower changeover switch on the transmitter to select [Only transmit from lower].
- 2 Press the upper/lower changeover switch on the receiver to select [Reception authorization on lower only].
- 3 Turn the adjustment screw to fine adjust until the tone reaches the highest pitch.
(Adjust both the transmitter and receiver.)

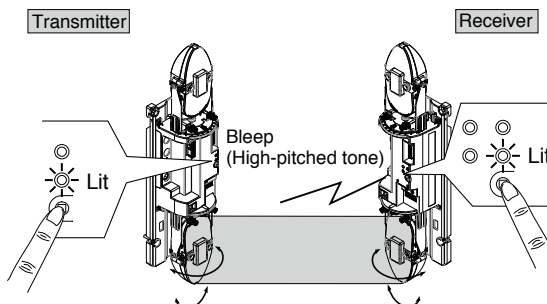

- 4 Check if the light from other transmitter doesn't enter the receiver.

- 1 Press the upper/lower changeover switch on the transmitter to select [No transmission].
- 2 Press the upper/lower changeover switch on the receiver to select [Reception authorized for both upper and lower].
- 3 Check that the alarm LED lights up, the receiver outputs an alarm signal, and the sensitivity attenuation LED is lit.

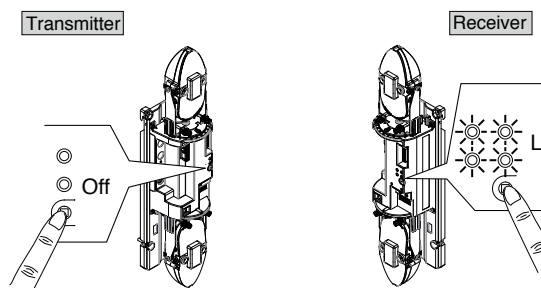

- 5 Return to the original settings.

- 1 Press the upper/lower changeover switches on the transmitter and receiver, and select [Reception authorized for both upper and lower].
- 2 Check that the upper/lower transmission/reception authorization LEDs are lit.
Also check that the alarm LED and sensitivity attenuation LED on the receiver are off.

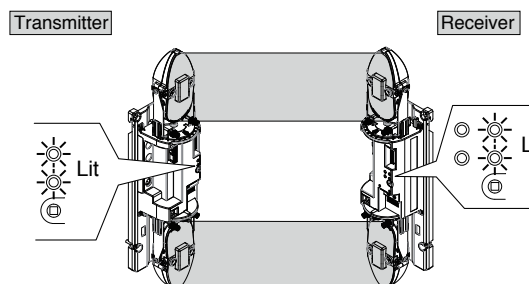

- If no alarm is activated or the sensitivity attenuation LED is not lit

When using multi-level protection, you may experience some adverse effects from other photoelectric beam sensors. In such cases, readjust the other photoelectric beam sensors to reduce the effects to the minimum.

In addition, check that an appropriate channel is set.

(4) MONITOR OUTPUT VOLTAGE

- More accurate adjustment of the optical axis can be achieved by checking the light reception level value using the voltage of the monitor output.



First, check only the transmission and reception on the upper level, and then check only the transmission and reception on the lower level.
(The values are not displayed correctly when reception of the beam is possible both the upper and lower levels.)

See the following table for the monitor output voltage.

Monitor Output Voltage	Reception Sensitivity
More than 2.4 V DC	Best
1.9 to 2.4V DC	Good
Less than 1.9V DC	Poor, re-adjust

- 1 Insert a commercially available tester into the monitor jack on the receiver.



The monitor jack is polarized.
Check the polarity of the tester pin before inserting it.
Use a tester with an internal resistance of over 1 MΩ.

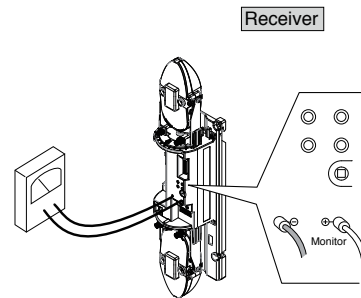

- 2 Fine adjust the upper level optical axis.

- 1 Press the upper/lower changeover switch on the transmitter to select [Only transmit from upper].
- 2 Press the upper/lower changeover switch on the receiver to select [Reception authorization on upper only].
- 3 Turn the adjustment screw to fine adjust until the monitor output voltage reaches the highest value.
(Adjust both the transmitter and receiver.)

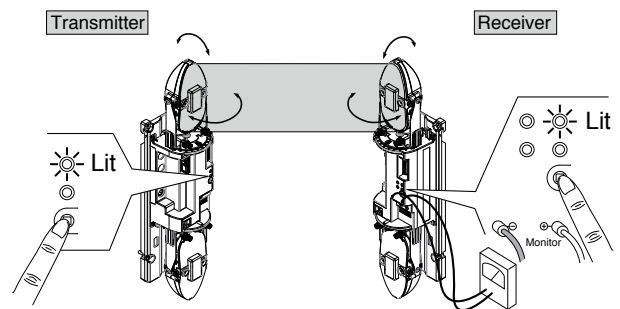

- 3 Fine adjust the lower level optical axis.

- 1 Press the upper/lower changeover switch on the transmitter to select [Only transmit from lower].
- 2 Press the upper/lower changeover switch on the receiver to select [Reception authorization on lower only].
- 3 Turn the adjustment screw to fine adjust until the monitor output voltage reaches the highest value.
(Adjust both the transmitter and receiver.)

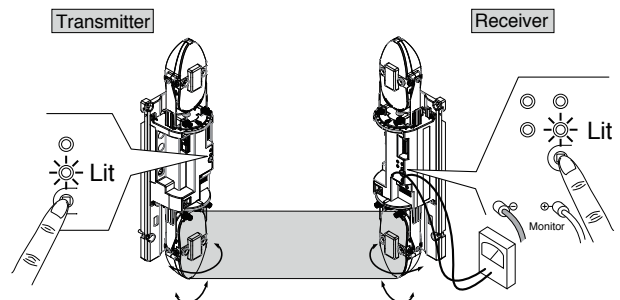

- 4 Check if the light from other transmitter doesn't enter the receiver.

- 1 Press the upper/lower changeover switch on the transmitter to select [No transmission].
- 2 Press the upper/lower changeover switch on the receiver to select [Reception authorized for both upper and lower].
- 3 Check that the alarm LED lights up, the receiver outputs an alarm signal, and the sensitivity attenuation LED is lit. Also check the monitor output voltage.

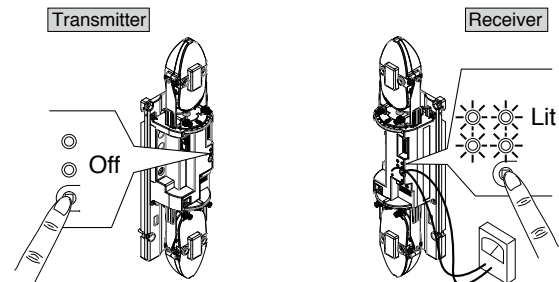

- 5 Return to the original settings.

- 1 Press the upper/lower changeover switches on the transmitter and receiver, and select [Reception authorized for both upper and lower].
- 2 Check that the upper/lower transmission/reception authorization LEDs are lit.
Also check that the alarm LED and sensitivity attenuation LED on the receiver are off.

- If no alarm is activated or the sensitivity attenuation LED is not lit

When using multi-level protection, the monitor output voltage may become close to "1 V" due to effects of other photoelectric beam sensors. In such case, readjust the other photoelectric beam sensors to reduce the effects to the minimum.
In addition, check that an appropriate channel is set.

(5) WIRELESS ALIGNMENT CHECKER: ER-02 (SOLD SEPARATELY)

- The wireless alignment checker ER-02 can be used to check the monitor output voltage both on the transmitter and receiver, which enables even one person to easily complete the correct optical axis adjustment.
Also, the light reception level can be checked during optical axis adjustment because the monitor output voltage can be checked.



When using the checker ER-02, set its power changeover switch to “supply from battery” (ER-02 built-in battery) for operation. In the event that each LED is lit after mounting the batteries and opening the cover, or beep of the sound check function sounds, the current draw can be approximately 10 to 20 times bigger than during standard operation. Therefore, the battery life decreases.

- Accurate adjustments of the optical axis can be achieved by checking the light reception level value using the voltage of the monitor output.
 - As the light reception level value can also be checked using the voltage on the transmitter, more accurate adjustments of the optical axis can be achieved. Using the wireless alignment checker enables easy and accurate beam alignment.
- Providing sufficient margin of sensitivity increases resistance to the dense fog, snow, and heavy rain, which makes it possible to construct a highly reliable intrusion alarm system.

Note: For detailed operation procedure of the wireless alignment checker, refer to the instruction manual of ER-02.

6 OPERATION CHECK Be sure to perform an operation check after the optical axis adjustment.

After optical axis adjustment is completed, set the transmitter and receiver Mode selector to “Operate”, and store them in the housing. Interrupt an area near the sensors on the detection line, or around the center of the detection line, and check that the alarm LED lights up along with the alarm transmission.



When the sound check function is set to ON, and the Mode selector is switched to “Operate”, the unit enters the walk test mode (activated for approximately 5 minutes after switching). The beep sounds in synchronization with the alarm output.



Be sure to check that the alarm transmission is received on the wireless receiver as well.



Be sure to set the Mode selector to “Operate”. (for both transmitter and receiver)
Otherwise, correct operation cannot be performed.

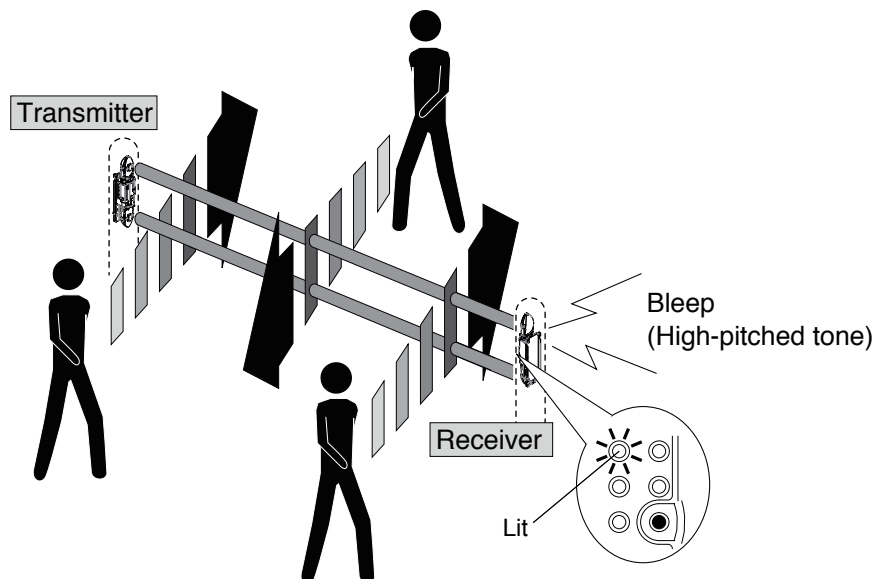

7 SENSOR FUNCTIONS

This section describes the functions equipped in the sensors. Refer to below and set the functions properly.

(1) MODULATION FREQUENCY CHANGEOVER FUNCTION

Note: Installed on the transmitter and the receiver

- Each channel has its own modulation frequency, which can prevent mutual interference or wraparound of the photoelectric beams. Set corresponding transmitters and receivers to the same channel.

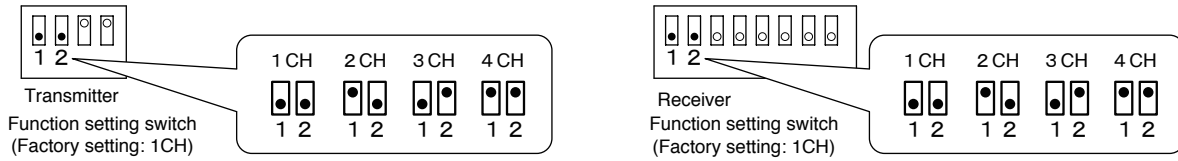

(2) DETECTION PROTECTION DISTANCE CHANGEOVER FUNCTION

Note: Only installed on the transmitter

- Changes beam power according to the protection distance. Setting the appropriate beam power can prevent wraparound and/or jumping over of the beams.

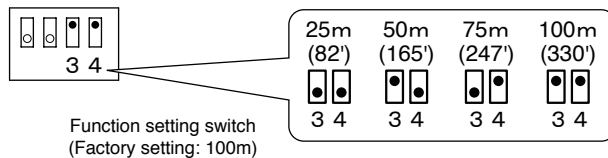

Setting	Corresponding protection distance
100m(330')	100m(330')~75m(247')
75m(247')	75m(247')~50m(165')
50m(165')	50m(165')~25m (82')
25m (82')	25m (82') or less

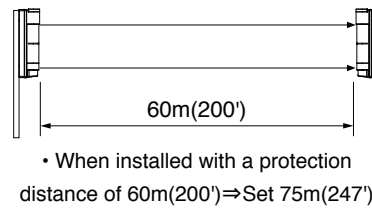
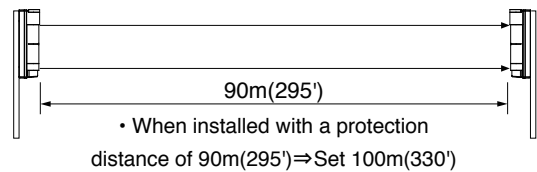

(3) RESPONSE TIME ADJUSTMENT FUNCTION

Note: Only installed on the receiver

- The interruption time of the detection can be adjusted. (Refer to the figures, and set the response time to the interruption time for detection objects)

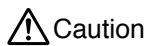
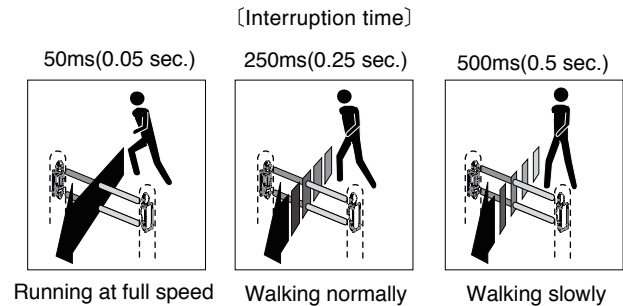
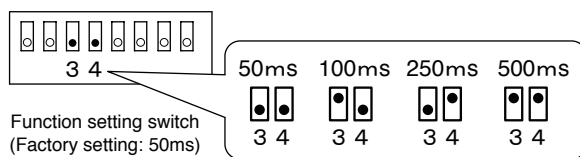

- (1) If the interruption time is shorter than the response time, the obstructing object is not detected.
 (2) In areas where there are large objects fluttering in the wind and obstruct the optical axis (e.g., birds, newspaper, and cardboard), set the response time slightly slower according to the installation condition. (However, if the response time is too slow, the units may not detect an intruder.)

(4) BATTERY SAVING FUNCTION

Note: Only installed on the receiver

- This function can be used to regulate the alarm output and environmental output, reduce current consumption, and extend the battery life. If there is a possibility that people often pass across the detection line, set this function. Once the alarm output is generated, next output is generated after approximately 15 minutes even if detection occurs.

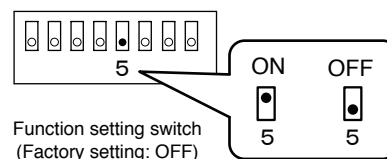

(5) REPEAT OUTPUT FUNCTION

Note: Only installed on the receiver

- When the unit outputs continuous alarm (e.g. beam path obstructed by a parked vehicle), or the environmental alarm is ceaselessly output, this function will repeat the output signal only every 2 minutes, or if the low battery warning is output it will repeat the output signal every 15 minutes. Note that using this function will result in the quicker consumption of batteries.

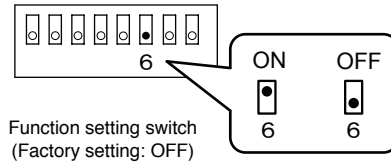

(6) SOUND CHECK FUNCTION

Note: Only installed on the receiver

- You can check status of the light reception or the alarm operation on the receiver by an audible tone.

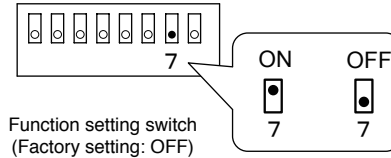

Item	Operation (status)	Other settings
Beam reception level	Beam reception level can be checked by the sound tone. (The tone pitch becomes higher as the light reception level increases.)	While the cover on the receiver is removed.
Walk test mode	Beep sound is generated according to the alarm output. (Activated approximately 5 minutes after Mode selector is switched to "Operate".)	

(7) UPPER/LOWER CHANGEOVER FUNCTION

Note: Installed on the transmitter and the receiver

- This function allows you to switch the optical unit to transmit/receive the beam by pressing the upper/lower changeover switch.

Note: The optical units switch as shown in the diagram below when the upper/lower changeover switch is pressed.

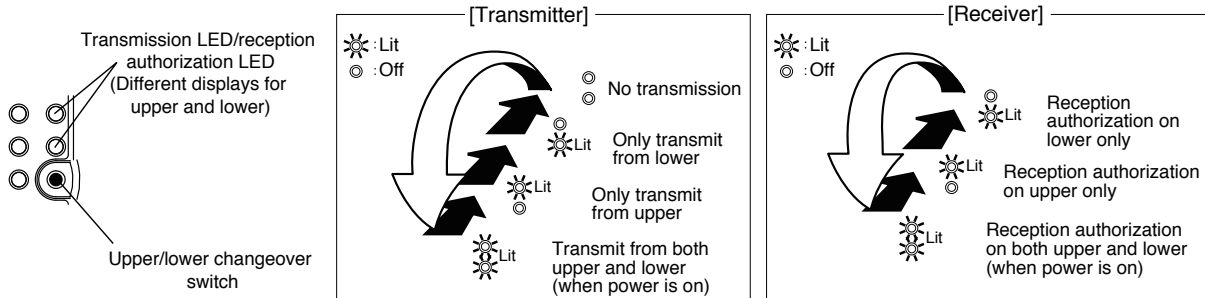

(8) SENSITIVITY ATTENUATION SIGNAL FUNCTION

Note: Only installed on the receiver

- The LED lights up when the light reception level is judged to be insufficient in order to notify the operator that inspection is necessary.

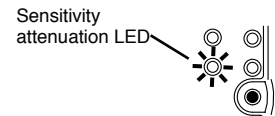

(9) LOW BATTERY DISPLAY FUNCTION

Note: Installed on the transmitter and the receiver

- This function is used to light up the transmission LED/reception authorization LED approximately every 5 seconds when the battery level is low. The lighting indication can be checked even when the Mode selector is set to "Operate".

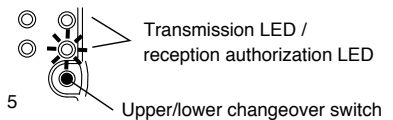

(10) WIRELESS ALIGNMENT CHECKER CONNECTION FUNCTION

Note: Installed on the transmitter and the receiver

- Using the wireless alignment checker (sold separately) enables easy and accurate optical axis adjustment. Providing sufficient margin of sensitivity increases the resistance to the dense fog, snow, and heavy rain, which makes it possible to construct a highly reliable intrusion alert system.

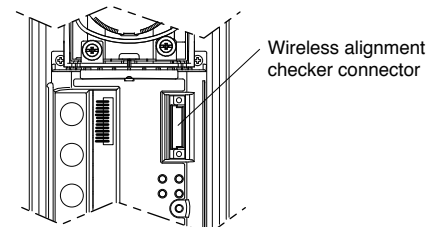

(11) MODE SELECTOR FUNCTION

Note: Installed on the transmitter and the receiver

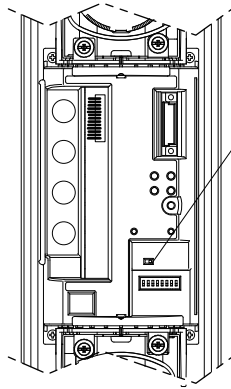

Mode selector

Operate
(Factory set)

This mode is used for operation, which is to minimize LEDs' lighting up, and reduce consumption. And also optimizes the transmission beam strength.

Alignment

This mode is used for adjustment, which is to light up the LED for adjustment, and optimize the transmission beam strength.



When adjusting beam alignment, please select "Mode selector" to "Alignment" on both the transmitter and the receiver in order to adjust the beam alignment accurately.

※After adjustment, make sure to return "operate" mode

8 TROUBLESHOOTING

• Check the device by referring to the table below. If you cannot restore the device to normal condition after the check, contact the place of purchase or TAKEX.

Status	Cause	Countermeasure
Transmitter LED does not light up (when the cover is open)	<ol style="list-style-type: none"> (1) Batteries are not placed in the transmitter (2) Batteries in the transmitter are exhausted (3) Batteries in the transmitter are placed with opposite polarity. (4) Connection failure or disconnection between the main unit and base (5) Transmitter is set to "No transmission". (6) The Mode selector is set to "Operate". 	<ol style="list-style-type: none"> (1) Mount batteries in the transmitter (2) Replace batteries in the transmitter with new ones (3) Correct the battery polarity in the transmitter (4) Check connection (5) Press the upper/lower changeover switch, and set to "Transmit" (6) Set the Mode selector to "Alignment".
Reception authorization LED does not light up	The Mode selector is set to "Operate".	Set the Mode selector to "Alignment".
Alarm LED does not light up when the infrared beams are interrupted	<ol style="list-style-type: none"> (1) Batteries are not placed in the receiver (2) Connection failure or disconnection between the main unit and base (3) The 4 beam paths are not interrupted simultaneously (4) Interrupted for shorter time than the detection response time (5) Infrared beams are reflected on any object, and enter into the receiver (6) Other beams enter into the receiver (7) Strong light or sunlight directly enter the optical axis of receiver. (Such as headlight of vehicle, IR illumination, the white light LED, etc.) 	<ol style="list-style-type: none"> (1) Mount batteries on the receiver (2) Check connection (3) Interrupt all 4 beam paths simultaneously (4) Set a shorter detection response time than the passing time (5) Remove reflective objects, or change the installation place and/or optical axis direction (6) Change direction of optical axis to prevent other beams from entering Alternatively, change the frequency channel settings (7) Switch location of receiver and transmitter.
Alarm LED continues to light (Alarm output does not stop)	<ol style="list-style-type: none"> (1) Optical axis (focus) is misaligned (2) There are obstacles between the transmitter and receiver (3) Covers or reflecting mirrors of the transmitter and receiver are dirty (4) Frequency channel settings of the transmitter and receiver do not match 	<ol style="list-style-type: none"> (1) Readjust the optical axis (2) Remove obstacles (3) Clean with a soft cloth (4) Match the frequency channel settings
Alarm is often generated intermittently	<ol style="list-style-type: none"> (1) Batteries are exhausted (2) Connection failure or disconnection between the main unit and base (3) There are obstacles between the transmitter and receiver (trees blowing in the wind) (4) Sensor installation is unstable (5) Covers or reflecting mirrors of the transmitter and receiver are dirty (6) Optical axis (focus) is misaligned (7) Big birds or cats sometimes interrupt the beams (8) Protection distance is longer than the protection distance setting on the transmitter (9) Strong light or sunlight directly enter the optical axis of receiver. (Such as headlight of vehicle, IR illumination, the white light LED, etc.) 	<ol style="list-style-type: none"> (1) Replace batteries with new ones (2) Check connection again (3) Remove obstacles (4) Fix the sensor securely (5) Clean with a soft cloth (6) Adjust the optical axis again (7) Set the detection response time to be slightly longer (Except the place where intruders can run through at full speed) (8) Change the setting according to the protection distance (9) Switch location of receiver and transmitter.
Alarm LED lights up, but the wireless transmitter does not operate	<ol style="list-style-type: none"> (1) Wiring to the wireless transmitter is disconnected (2) Wiring to the wireless transmitter is wrong 	<ol style="list-style-type: none"> (1) Check connection again (2) Check connection again

Maintenance

- To clean the device, use a soft, wet cloth and then wipe off any water drops.
- If the device is particularly dirty, dip the soft cloth in the water that contains a weak neutral detergent. Wipe the device gently with the cloth, then wipe off any detergent that remains. Do not use substances such as thinner or benzene. (The plastic parts may deform, discolor or change their properties.)
- Perform operation checks on a regular basis.

9 SPECIFICATIONS

BATTERY OPERATED PHOTOELECTRIC BEAM SENSOR	
Model	TXF-125E-KH
Detection system	Near infrared pulsed beam interruption system (TR-RE 4 beam simultaneous interruption)
Infrared beam	Single modulation pulsed beam by LED (near infrared beam light-emitting diode)
Protection distance	Outdoor 100 m(330') or less
Protection distance setting	25m(82'), 50m(165'), 75m(247'), 100m(330') (4 distances selectable)
Distance margin (maximum arrival distance)	10 times 1000m(3300')
Response time	50ms, 100ms, 250ms, 500ms (4-level changeover)
Modulated beam frequency selection	4 channels
Power supply voltage	3.6VDC (recommended battery: SAFT lithium thionyl chloride battery LS33600)
Current consumption	750 μ A Transmitter : Approx. 430 μ A (during protection) Receiver : Approx. 320 μ A (during protection) (normal temperature, 3.6V DC)
Battery life	Transmitter : Approx. 5 years (at normal temperature, with 2 recommended batteries, excluding a wireless transmitter) Receiver : Approx. 5 years (detects 100 times a day, at normal temperature, with 2 recommended batteries, excluding a wireless transmitter)
Alarm output (receiver only)	Dry contact relay output form C 30V DC 0.1A (resistive load)
Environment output (receiver only)	Dry contact relay output form C 30V DC 0.1A (resistive load)
Low battery output (transmitter and receiver)	Dry contact relay (N.C) 30V DC 0.1A (resistive load)
Power output (transmitter and receiver)	3.0V DC 65mA MAX
Beam adjustment	Horizontal : $\pm 90^\circ$, Vertical: $\pm 20^\circ$
Alarm LED	Red LED (Receiver) ON : when alarm is initiated
Attenuation LED	Red LED (Receiver) ON : when beam is attenuated
Ambient temperature	-25°C to +60°C (-13°F to +140°F) (No freezing or condensation) (The battery function may decrease at 0°C or less, or +40°C or more)
Functions	Sound check Monitor jack Upper/lower beam switch Low battery indication Wireless alignment checker connection Battery saving Repeat output Battery sharing
Mounting position	Outdoor, Indoor
Weight	Transmitter : Sensor Unit 500g (17.5oz) ,Base 620g (21.7oz) excluding batteries Receiver : Sensor Unit 550g (17.5oz) ,Base 620g (21.7oz) excluding batteries
Appearance	Sensor unit : Resin Base : Resin (Black)

* Specifications and design are subject to change without prior notice.

10 EXTERNAL DIMENSIONS Unit: inch (mm)

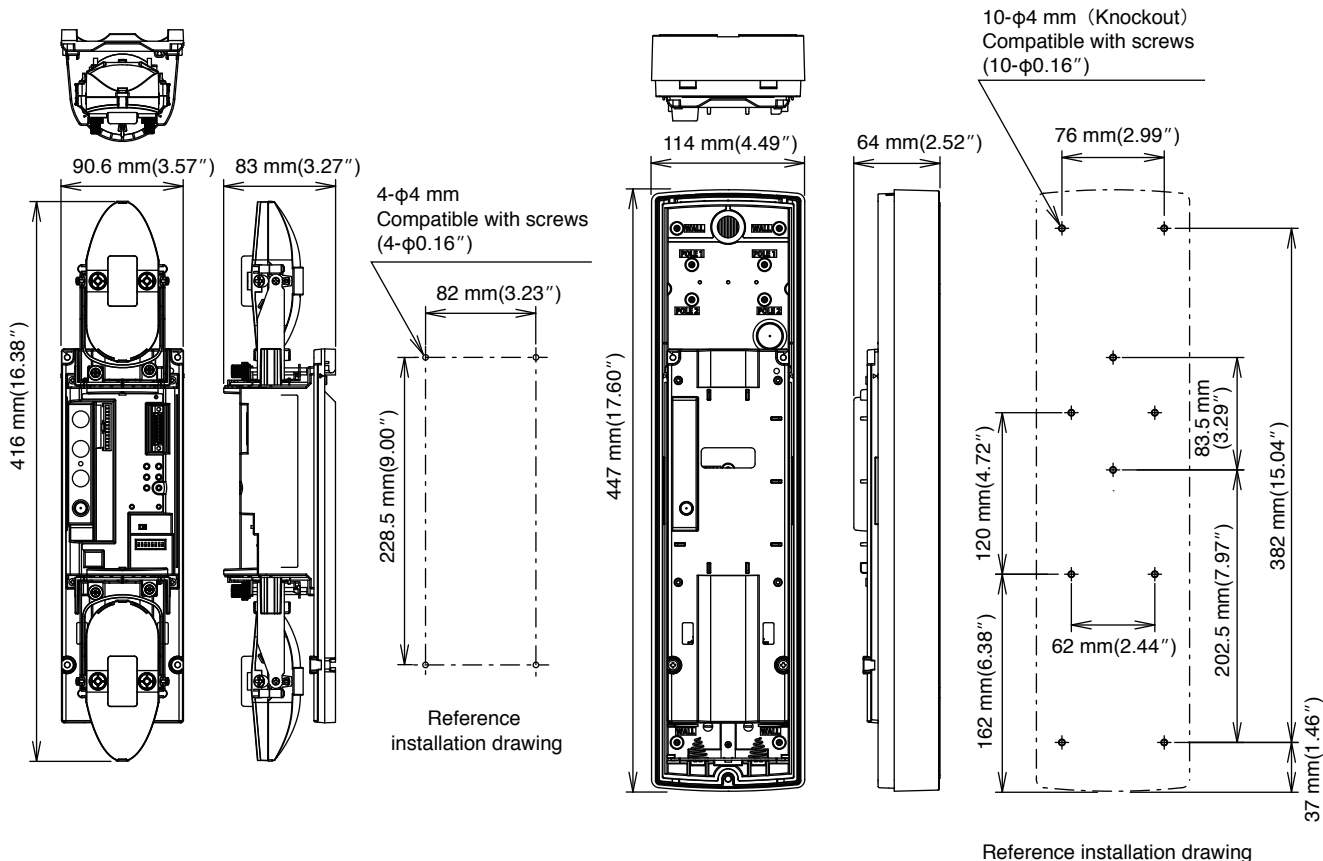

■ Options : Alignment wireless checker : ER-02

Limited Warranty :

TAKEX products are warranted to be free from defects in material and workmanship for 12 months from original date of shipment. Our warranty does not cover damage or failure caused by Acts of God (including inductive surge by lightning), abuse, misuse, abnormal usage, faulty installation, improper maintenance or any repairs other than those provided by TAKEX. All implied warranties with respect to TAKEX, including implied warranties for merchantability and implied warranties for fitness, are limited in duration to 12 months from original date of shipment. During the Warranty Period, TAKEX will repair or replace, at its sole option, free of charge, any defective parts returned prepaid. Please provide the model number of the products, original date of shipment and nature of difficulty being experienced. There will be charges rendered for product repairs made after our Warranty period has expired.



In Japan

Takenaka Engineering Co., Ltd.
83-1, Gojo-Dori, Sotokan Nishi-iru, Higashino,
Yamashina-ku, Kyoto 607-8156, Japan
Tel : 81-75-501-6651

<https://www.takex-eng.co.jp/>

In the U.S.

Takex America Inc.
1810 Oakland Rd, Suite F,
San Jose, CA 95131, USA
Tel : 408-747-0100

<https://www.takex.com>

In Australia

Takex America Inc.
4/15 Howleys Road, Notting Hill,
VIC, 3168
Tel : +61 (03) 9544-2477

<https://www.takex.com>

In the U.K.

Takex Europe Ltd.
Aviary Court, Wade Road,
Basingstoke, Hampshire. RG24 8PE, U.K.
Tel : (+44) 01256-475555

<https://www.takex.com>