

1 Year Limited Warranty

Channel Vision Technology will repair or replace any defect in material or workmanship which occurs during normal use of this product with new or rebuilt parts, free of charge in the USA, for one year from the date of original purchase. This is a no hassle warranty with no mail in warranty card needed. This warranty does not cover damages in shipment, failures caused by other products not supplied by Channel Vision Technology, or failures due to accident, misuse, abuse, or alteration of the equipment. This warranty is extended only to the original purchaser, and a purchase receipt, invoice, or other proof of original purchase date will be required before warranty repairs are provided.

Mail in service can be obtained during the warranty period by calling (800) 840-0288 toll free. A Return Authorization number must be obtained in advance and can be marked on the outside of the shipping carton.

This warranty gives you specific legal rights and you may have other rights (which vary from state to state). If a problem with this product develops during or after the warranty period, please contact Channel Vision Technology, your dealer or any factory-authorized service center.

Channel Vision products are not intended for use in medical, lifesaving, life sustaining or critical environment applications. Channel Vision customers using or selling Channel Vision products for use in such applications do so at their own risk and agree to fully indemnify Channel Vision for any damages resulting from such improper use or sale.

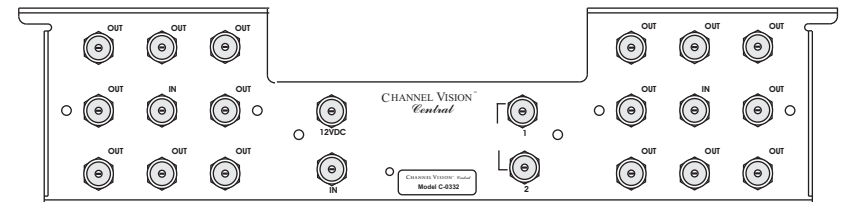

C-0332 16 Port Amplified Splitter

The **C-0332** is an amplified splitter system that allows an antenna or CATV feed to be distributed to 16 different locations. The system consists of one CVT-1/2PIA dual output amplifier and two HS-8V 8-way splitters. These components are mounted inside a metal bracket that enables the system to be easily installed in a Channel Vision structured wire enclosure.

Features:

- Allows 5-42MHz return path for interactive digital cable boxes
- Unity gain output
- DC and IR passing splitters

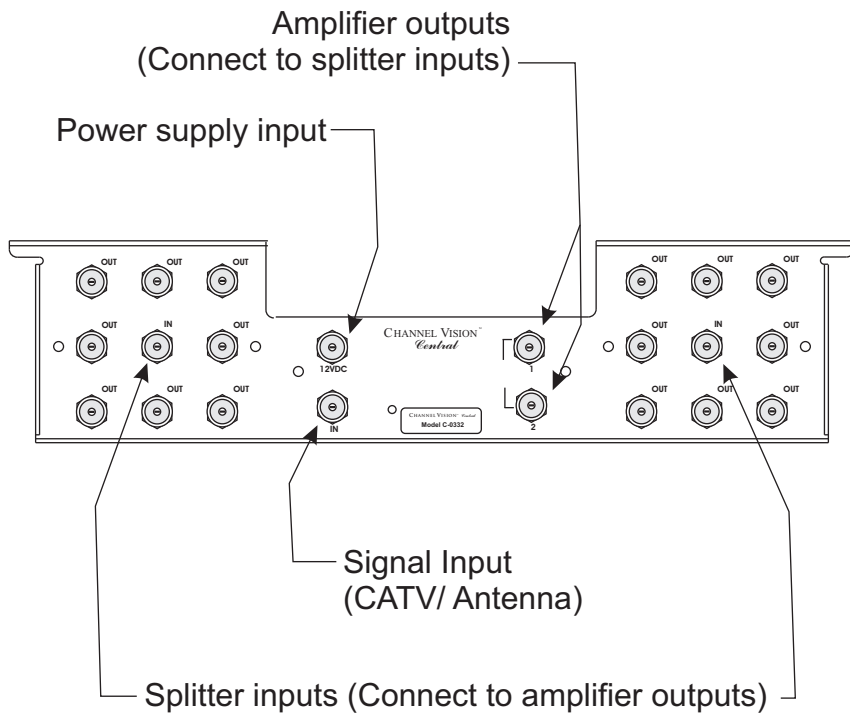

Troubleshooting

Diagonal lines on modulator channels only: Try moving the modulator to another channel number. You may need to add a low pass to remove cable company noise.

Diagonal lines on many channels (vanish when you remove the CATV feed.) The RF amplifier is being overloaded by over-strong cable signals. Add an attenuator to reduce the signal strength.

Cable channels have interference when modulator is connected: Reduce the modulator signal by using an attenuator. Either a fixed or variable attenuator may be used.



Variable attenuator

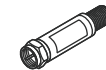

Fixed attenuator

Specifications: (typical @25° C)

Gain

Cable In to Out: Unity
54MHz - 1000MHz

Reverse Gain

Out to Cable In: -14dB
5 - 42MHz

Isolation Out / Cable In: -80dB 450MHz - 1000MHz

Flatness: ± 1dB (all outputs terminated)

Noise Figure: 7dB (maximum)

IR Passing: All ports

RFI rejection: -130dB (minimum)

Power supply: 12VDC @ 300mA (supplied)

Specifications subject to change without notice.

Other Compatible Products

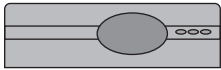

Modulators:
**CVT1ub/uhf-II, CVT2ub/uhf-II, CVT3ub/uhf-II,
E1200, E2200IR, E3200IR, and E4200IR**

Channel Vision modulators allow you to create your own TV channel for video devices so they can be easily distributed through your home. Common uses include CCTV cameras, DVD players, and satellite receivers.



**IR coax engine:
IR-4000**

The IR-4000 is the heart of the coax IR repeating system. It allows power to be inserted on the coax and it provides an IR emitter port to output the IR control signals. An IR engine is built into the E2200IR, E3200IR, and E4200IR modulators.

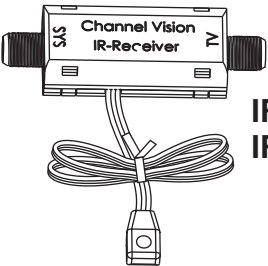

**IR over coax adaptor:
IR-4101**

The IR-4101 is an IR over coax receiver to be connected into the system on each output where IR control is needed.

IR receivers detect the IR signal from your remote control and convert them into pulses that can travel over a wire, in this case coax cable.

For more information please go to www.channelvision.com.

Frequently Asked Questions

Why do I need a 5-42MHz return path?

Unlike conventional cable TV systems, new digital cable systems require the cable box to have two-way communication with the cable company. This means that signals need to travel from the cable company to your home and then from your home back to the cable company. The frequency range between 5MHz and 42MHz has been reserved for the return communication signals. Traditional RF amplifiers that were designed before the advent of digital cable did not accommodate this return communication and would not allow digital cable boxes to function properly.

What are DC passing splitters?

Some products utilize your existing coax cable to distribute IR control signals throughout your home. This technology requires a Direct Current (DC) voltage to be transmitted over the coax wire. Conventional RF splitters will cause this voltage to short out and disable the IR repeating system. Most Channel Vision Splitters are DC passing and will support this kind of IR repeating technology.

What is IR repeating?

IR repeating systems allow you to use a handheld infrared remote to control devices that are located in another room of your home. Channel Vision offers a variety of IR repeating solutions, please visit www.channelvision.com for a complete list.



How should I connect my cable modem?

Although the 5-42MHz return path provided by the amplifier will allow the modem to communicate with the cable company network, connecting your modem directly to the amplified splitter is not recommended. Doing so can allow the modem signal to be corrupted by noise generated by TV sets that are connected to the other outputs. See the diagram on the following page for the recommended setup.

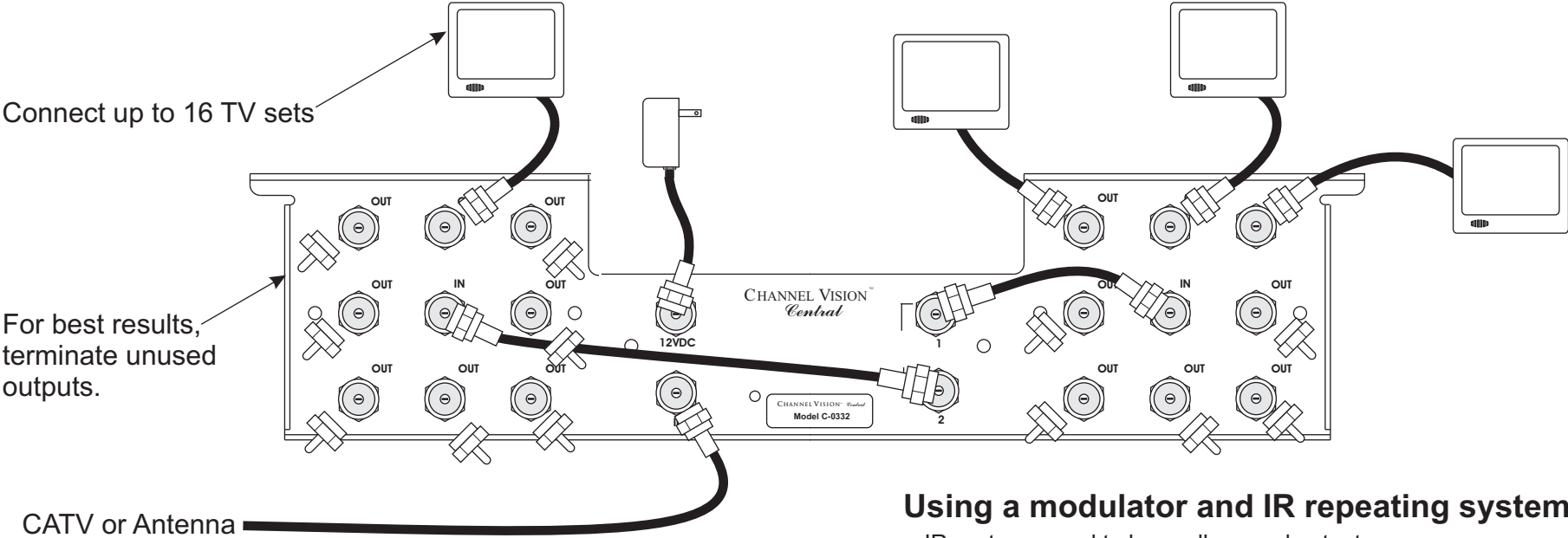
Basic Setup



Useful Accessories:

-  DC Block (model 3109)
These are often needed when installing an IR repeating system (see diagram)
-  75 Ohm terminator (model 2101)
These are needed to terminate unused TV outputs (see diagram)

Using a Cable modem

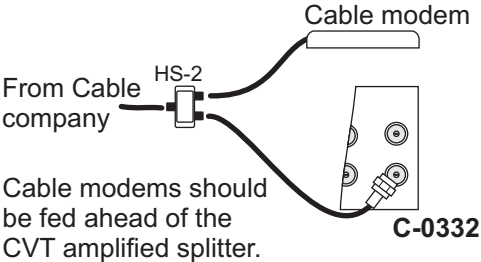

Using a modulator and IR repeating system

IR systems need to have all unused outputs connected to DC blocked terminators. Up to 4 IR receivers can be powered by one IR-4000.

