

This Package contains:

Quantity	Description
1	Category 5e Angled Patch Panel w/ Cable Management Bar(s)
1	Package of four (4) screws

Tools Required for Installation:

1	Screw Driver
1	110 Punchdown tool

This installation procedure shall be used with all **Category 5e Angled Patch Panel** products.

Step 1: Line up the holes at the corners of the panel with the corresponding mounting holes of the EIA compliant rack. Secure the panel with the four (4) screws provided. Attach cable management bar(s) to the rear of the rack with (2 or 4) screws. See Figure 1.

OCC Tip: A Cable Management Panel should be placed between each patch panel for patch cord routing. OCC offers a full line of single and double-sided Cable Organizers. Please consult the OCC catalog for available options.

Step 2: Carefully arrange, organize, and bundle the UTP cable to be terminated at the patch panel. Be careful not to

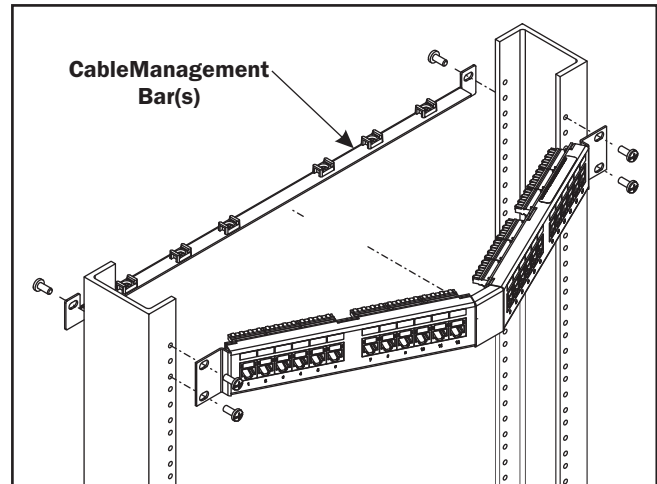

Figure 1

compress or deform the cable bundle when using cable ties. Check the cable number, patch panel, and termination modules to which the cable is to be terminated and direct cables accordingly using sound cable management procedures.

Caution: Cable Management precautions: All effort should be made to eliminate cable stress caused by tension in suspended cable runs and cable bundles that are tightly cinched. Cable bend radius shall not be less than four times the cable diameter. When terminating horizontal cable, strip back the cable jacket only as much as needed to terminate on connecting hardware.

Step 3: Measure and cut to length (plus 1 ½" for stripping and termination) the cable to be terminated at the 110 module on the rear of the panel using sweeping bends. Strip the cable jacket back 1 ½" being careful not to nick or scrape the conductor insulation. See Figure 2.

Step 4: Position the cable at the appropriate 110 module and insert the cable into the color coded slots of the 110 connectors. The white conductor of each pair shall be inserted right of the color code and the solid colored conductor to the left of the color code. Be sure to follow the appropriate color code associated with desired wiring pattern (T568B or T568A). See Figures 3 and 4.

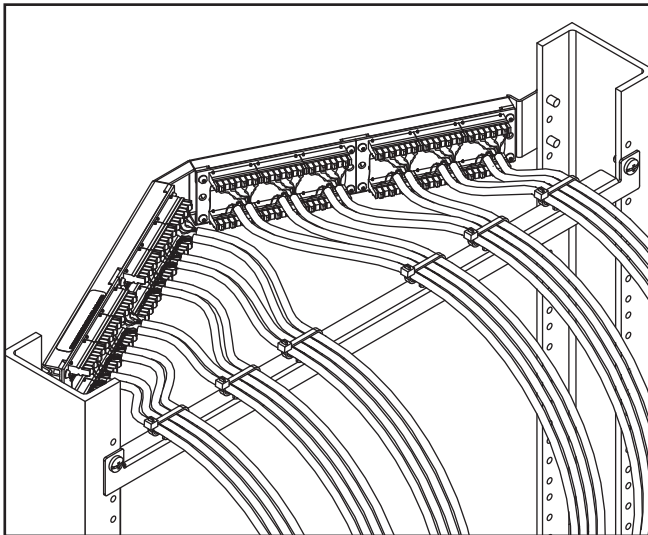

Figure 2

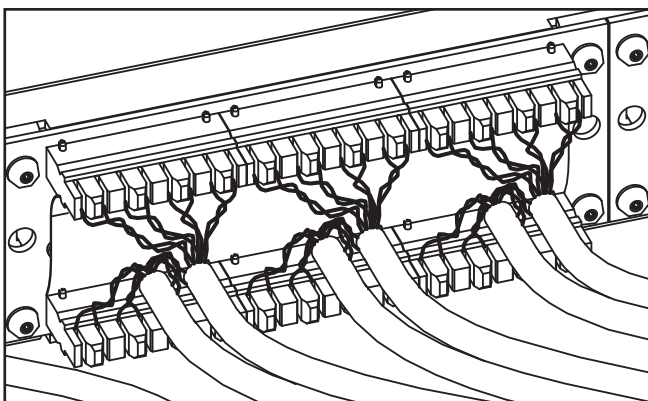

Figure 3

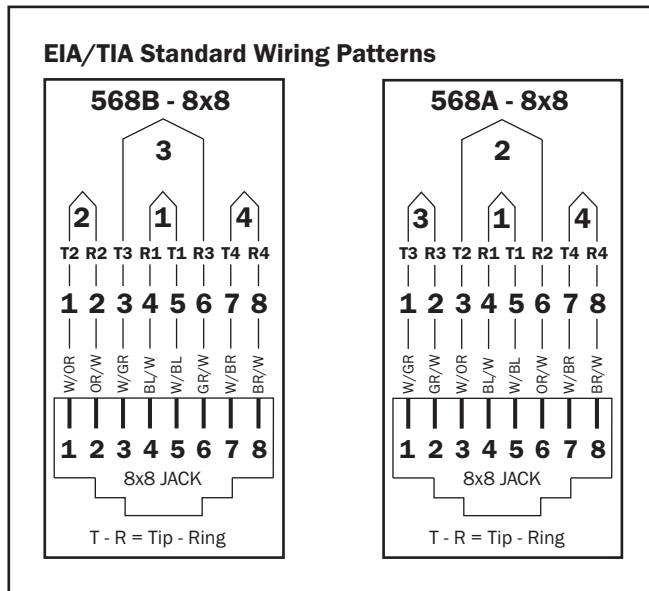

Figure 4

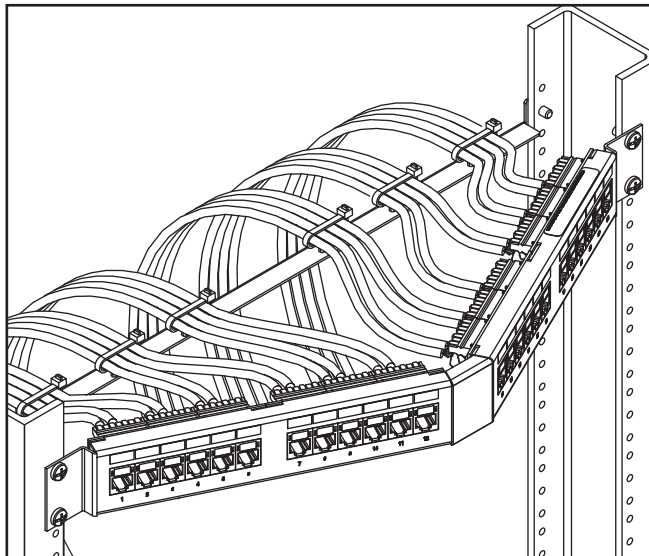

Figure 5

Caution: *THE MAXIMUM UNTWIST OF A CATEGORY 5E CABLE PAIR IS 1/2".*

Step 5: Using a 110 punchdown tool, make sure the cutoff blade is in the correct direction, then complete the termination by pressing on the handle of the punchdown tool until it toggles. The tool automatically terminates and cuts off the excess conductor. The installer may use the low or high impact setting on the tool.

Caution: *DO NOT USE THE 788J1 IMPACT TOOL TO TERMINATE THE CONDUCTORS. THE 788J1 TOOL IS NOT DESIGNED TO BE USED WITH 110D CONNECTING BLOCKS, AND ITS USAGE MAY DAMAGE THE PANEL.*

Step 6: Complete the termination of the remaining patchpanel 110 modules following the above steps and dress each cable and secure in place. See Figure 5.

Step 7: Connecting patch cords between patch panels and electronic equipment is accomplished using OCC patch cords and Cable Organizers utilizing sound cable management practices.

In order to guarantee maximum performance from your Optical Cable Corporation products connecting hardware, Optical Cable Corporation recommends utilizing OCC Category 5E patch cords for cross connect and station cords to connect the computer to the station outlet.

Thank you for purchasing Optical Cable Corporation's **Category 5e Angled Patch Panel** products.