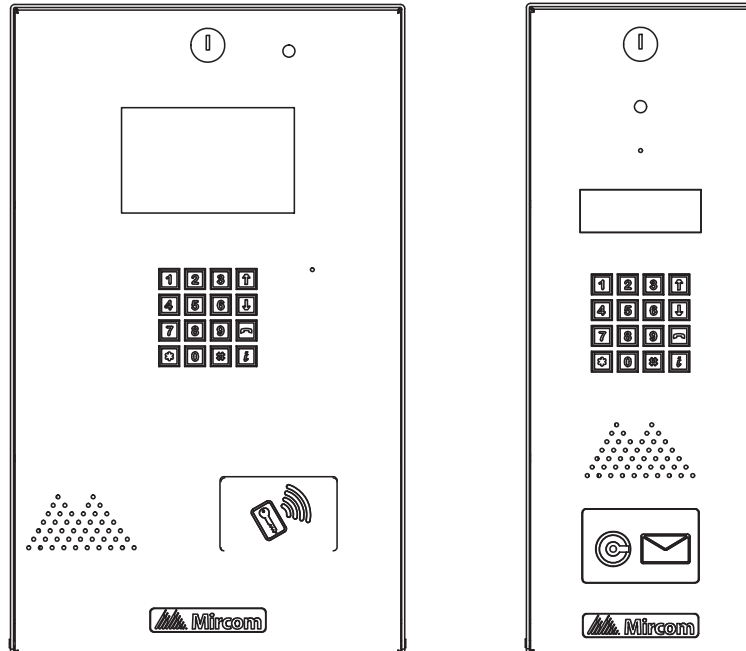


# TX3 Series

## TELEPHONE ACCESS SYSTEMS



## Installation and Operation Manual



*March 2023 Mircom Inc.*

*All rights reserved.*

TX3 Installation and Operation Manual v 7

Microsoft, MS-DOS, Windows, and Windows 2000/NT/XP/Vista/7/8/10 are either registered trademarks or trademarks of Microsoft Corporation in the United States and/or other countries.

Mircom  
25 Interchange Way  
Vaughan, Ontario  
L4K 5W3  
905.660.4655  
<http://www.mircom.com>

# Contents

<b>1</b>	<b>Introduction</b>	<b>8</b>
1.1	TX3 Systems	9
1.2	Features	11
1.3	Lobby Control Unit Enclosures	12
1.4	Lobby Control Unit Accessories	17
1.5	Maximum and Minimum Mounting Heights to Comply with the ADA (Americans with Disabilities Act)	18
1.6	Mounting requirements from the 2010 ADA Standards for Accessible Design	19
1.7	About This Manual	20
1.8	Warranty and Special Notices	20
1.9	Contact Us	20
<b>2</b>	<b>Enclosure Installation</b>	<b>21</b>
2.1	Ground the Telephone Access System	21
2.2	Install the Enclosures and Lobby Control Unit	21
2.3	Install the Heater	37
<b>3</b>	<b>TX3 System</b>	<b>38</b>
3.1	TX3 System	38
3.2	Single Lobby Control Unit	39
3.3	Dual Lobby Control Units	42
3.4	Three Lobby Control Unit Configuration	43
3.5	Multiple Lobby Control Units	44
3.6	Networking TX3 Panels	44
3.7	Lobby Control Unit Wiring	47
<b>4</b>	<b>Lobby Control Unit Setup</b>	<b>48</b>
4.1	Controller Board	49
4.2	Controller Board Connectors - Bottom	51
4.3	Controller Board Connectors - Top	56
4.4	Modem Module	59
4.5	IP Module	60
4.6	RS-485 Add-on Module	60
4.7	Wiegand Output Module	62
4.8	Guard Phone Module	62
4.9	Guard Phone	63
4.10	Controller ID Setup	64
4.11	Configuration Using a PC	66
4.12	Updating Firmware	67
4.13	Beginning Configuration	68

<b>5</b>	<b>NSL Relay Cabinet Installation and Wiring</b>	<b>69</b>
5.1	NSL Relay Cabinet Mechanical Installation	70
5.2	NSL Relay Control Unit and Expanders	72
5.3	Wiring the TX3-NSL-8M Main Controller Board	75
5.4	Updating Firmware	92
<b>6</b>	<b>Adding Controllers and Accessories</b>	<b>93</b>
6.1	Add a Controller	93
6.2	Install the TX3-P300-HA Card Reader	94
<b>7</b>	<b>Specifications</b>	<b>96</b>
<b>8</b>	<b>Resident Operating Instructions</b>	<b>98</b>
8.1	NSL Resident Operating Instructions	99
8.2	ADC Resident Operating Instructions	101
	<b>Warranty &amp; Warning Information</b>	<b>102</b>
	<b>Special Notices</b>	<b>107</b>

## List of Figures

Figure 1	TX3-200-8U-C, TX3-1000-8U-C, TX3-2000-8U-C, TX3-120U-C Dimensions	22
Figure 2	Dimensions of TX3-UFT and the Universal Enclosure	23
Figure 3	Mount TX3-UFT Universal Series Flush Trim Ring	23
Figure 4	Dimensions of TX3-2000-8UR-C	25
Figure 5	Dimensions of TX3-2000-8UR-C with TX3-UFTR	25
Figure 6	Mount TX3-2000-8UR-C into TX3-UFTR	26
Figure 7	TX3-200-4U-C, TX3-1000-4U-C, TX3-2000-4U-C Dimensions	27
Figure 8	Dimensions of TX3-USFT and the Universal Slim Line Enclosure	28
Figure 9	Mount TX3-USFT Universal Slim Line Flush Trim Ring	29
Figure 10	Dimensions of TX3-2000-4UR-C	30
Figure 11	Dimensions of TX3-2000-4UR-C with TX3-USFTR	31
Figure 12	Mount TX3-USFTR Semi-Flush Trim Ring for Reinforced Universal Slim Line Enclosures (door not shown)	32
Figure 13	TX3-200-8C-C, TX3-1000-8C-C, TX3-2000-8C-C, TX3-120C-C Dimensions	33
Figure 14	Mount the Continental Enclosure	34
Figure 15	Dimensions of TX3-2000-8CR-C	35
Figure 16	Mount TX3-2000-8CR-C	36
Figure 17	Heater TH-102 Installation Location	37
Figure 18	Single Lobby Control Unit	39
Figure 19	Single Lobby Control Unit with ADC and NSL Lines	40
Figure 20	Single Entrance System Wiring	41
Figure 21	Dual Lobby Control Units	42
Figure 22	Multiple Lobby Control Units to Multiple Lines	43
Figure 23	Many Lobby Control Units to One Line	44
Figure 24	TX3 devices on an RS-485 network.	45
Figure 25	TX3 devices on an Ethernet TCP/IP network.	45
Figure 26	Lobby control units using both Ethernet and RS-485 networks	46
Figure 27	Lobby Control Unit Wiring	47
Figure 28	Lobby Control Unit Main Controller Board	49
Figure 29	Controller Board Connectors - Bottom	51
Figure 30	Tamper Switch	52
Figure 31	RS-485 Wiring	54
Figure 32	Power Supply	55
Figure 33	Controller Board Connectors - Top	56
Figure 34	Main Door Dry Contact Wiring	58
Figure 35	Modem Module Telephone Connectors	59
Figure 36	IP Module Data and Ethernet Connectors	60
Figure 37	RS-485 Add-on Module	61
Figure 38	Guard Phone Module	63
Figure 39	NSL Relay Cabinet	70
Figure 40	TX3-NSL-8M Relay Control Unit	72
Figure 41	NSL Expanders	74
Figure 42	TX3-NSL-8M Main Controller Board	75
Figure 43	NSL System with Telephone Line	77
Figure 44	NSL Controller Telephone Lines	78

Figure 45	NSL Backplane	<b>80</b>
Figure 46	ADSL-100 Filter Module Installation	<b>81</b>
Figure 47	Backplane Number Section	<b>82</b>
Figure 48	2012 NSL Relay Board	<b>85</b>
Figure 49	CA-71A BIX Block Wiring Configuration	<b>86</b>
Figure 50	RJ-71C Punch-Down Block Wiring Configuration	<b>89</b>
Figure 51	Remove the 2 screws	<b>94</b>
Figure 52	Install TX3-P300-HA	<b>95</b>

## List of Tables

Table 1	RS-485 Add-on Jumper Settings	<b>61</b>
Table 2	TX3-WIEGAND-OUT Output	<b>62</b>
Table 3	Lobby Control Unit SW1 DIP Switch Settings	<b>65</b>
Table 4	NSL Relay Cabinet Dimensions	<b>71</b>
Table 5	Sample Backplane Relay Addresses	<b>83</b>
Table 6	CA-71A BIX Block Identification Form	<b>87</b>
Table 7	RJ-71C Punch-Down Block Identification Form	<b>90</b>

# 1 Introduction

This manual provides information about the installation and operation of the Telephone Access System, and must be read in its entirety before beginning any installation work.

Installation must be performed by a qualified technician and must adhere to the standards and special notices set by the local regulatory bodies.

For warranty and special notices information see the Warranty chapter on page 104 and Special Notices on page 109.

---

**Note:** Mircom periodically updates panel firmware and Configurator Software to add features and correct any minor inconsistencies. For information about the latest firmware or software visit the Mircom website at [www.mircom.com](http://www.mircom.com).

---

---

**Warning:** **The lobby control unit must be grounded by a qualified electrician. An improperly grounded unit can result in equipment malfunction and electrical shock.**

**If you mount the lobby control unit outdoors, follow these precautions:**

**Do not install the lobby unit in direct sunlight. Use the rain hood and do not expose the lobby unit to the elements. Make sure the lobby unit is covered by a minimum 2 m (6 feet) overhang in all directions.**

**Seal the openings in the lobby unit with outdoor-rated weatherproof silicone.**

**Do not power wash the lobby unit.**

**Review our warranty and terms and conditions, available at these links:**

<https://www.mircom.com/product-warranty>

<https://www.mircom.com/purchase-terms-and-conditions>

<https://www.mircom.com/software-license-terms-and-conditions>

---

## **This manual explains**

- Lobby Control Unit Installation and Operation
- NSL Control Unit Installation and Operation
- Card Reader Unit Integration



## 1.1 TX3 Systems

The Mircom's TX3 series of telephone access systems provide high quality two-way communication between residents and their visitors in a multi-unit dwelling establishment.

The basic TX3 system consists of the TX3 Lobby Control Unit and depending on the application, may be integrated with a combination of Mircom Elevator Restriction Units, Card Access Units and Touch Screens. All access systems may be networked together using either a peer-to-peer RS-485 connection, an Ethernet TCP/IP connections, or an Ethernet TCP/IP network with RS-485 subnetworks.

The TX3 system is capable of providing ADC or NSL type telephone access control from a single panel or from a networked system.

A maximum of 63 units are supported with any combination of Touch Screens, Lobby Control Units, Elevator Restriction Units and Card Access Units. Valid network addresses range from 1 to 63. One of the networked units with a real time clock, such as Touch Screen, Lobby Control or Card Access must have their network address set to 1. In addition, units can be connected to either an Ethernet TCP/IP network or a combination Ethernet TCP/IP network with RS-485 subnetworks, both of which allow more than 64 units to be networked. See section 3.6 on page 44 for more information.

The access system can be configured as an autodialer controller (ADC) or as a no subscriber line (NSL) system. Both system setups can be configured for multiple entrances with independent doors and control devices such as electric door locks, cameras, and garage doors.

### 1.1.1 ADC and NSL Capability

TX3 supports full ADC and NSL telephone connectivity from a single Telephone Access System panel or from a networked system. A single panel supports up to five ADC and/or NSL telephone lines.

An ADC connection requires a dedicated subscriber telephone line service connected to an outside telephone line. This connection lets the visitor call the tenant and access their voice mail.

An NSL type connection uses the existing building telephone lines for communication and does not require a separate telephone line. This system may consist of one or more Lobby Control Units connected to TX3-NSL-8M NSL

Units, typically located in the electrical/telephone room of a building. The NSL units intercept all telephone lines into the building's suites and communicate directly to the resident phone using the Lobby Control Unit.

---

**Note:** Non-configurable PBX systems are not supported. For more information, contact technical support at Mircom.

---

### 1.1.2 Elevator Restriction Units

The TX3-ER-8-A and TX3-ER-8-B Elevator Restriction Units limit building accessibility by granting visitor access only to the destination floor.

### 1.1.3 Other Controllers

Other Mircom controllers, such as the Elevator Restrictor Unit and the Card Access controller, may be networked with the Lobby Control Unit. The network options include a peer-to-peer RS-485 network, an Ethernet TCP/IP network, or a combination Ethernet TCP/IP network with RS-485 subnetworks. See section 3.6 on page 44 for more information.

---

**Notes:** In order for a panel to connect to an Ethernet TCP/IP network:

- it must be IP capable. Panels described in this manual are IP capable.
- it must have a TX3-IP IP Module installed if it is not a Touch Screen.

---

## 1.2 Features

Features of the TX3 series include:

- Stainless steel front panel
- Universal Series enclosure with a built-in rain hood
- Large scrolling 8 x 20 LCD display that eliminates the need for an external directory
- Back-lit 16 digit keypad with dedicated operational buttons for Page Up, Page Down, Call and Info
- Provisions for postal lock and camera
- Multilingual Display and Voice Greeting (English, French-Canadian and Spanish) that provides instructions on how to use the Lobby Control Unit
- Concierge/Security Desk/Guard Phone capability
- Card Access Interface
- Supports both Auto Dialer (ADC) and NSL (no phone bill)
- Ability to network panels together (peer-to-peer)
- Hands free, full duplex communication
- Flexible one to four digit resident dial codes
- Dials up to 18 digit telephone numbers
- System can be configured locally using the keypad or a computer with the TX3 configuration software
- Upload/download configuration files without taking the whole system off-line
- Programming from one location
- Records a maximum of 5000 event logs
- Elevator restriction capability
- Schedule based call restrictions provide more security and flexibility
- Auto Unlock to leave the main door based on the selected schedule
- Capability of one person testing the NSL controller without using the Lobby Control Unit
- Industry Canada and F.C.C. approved

## 1.3 Lobby Control Unit Enclosures

There are four series of enclosures for Lobby Control Units:

**Universal Series.** The Universal Series enclosure is an indoor/outdoor unit for the scrolling Lobby Control Unit.

**Universal Slim Line Series.** The Universal Slim Line enclosure is an indoor/outdoor unit that is narrower and longer than the Universal and Continental series, and is for the scrolling Lobby Control Unit. This series is also available as a kit.

**Continental Series.** The Continental Series is a stainless steel indoor unit larger than the Universal Series and is for the scrolling Lobby Control Unit.

**Kiosk Free Standing.**

### 1.3.1 Universal Series

The Universal Series enclosures are surface or semi-flush mounted with the Lobby Control Units. Optional flush trim rings are available for semi-flush and flush installations. A rain hood is included allowing for outdoor use.

The following Universal Panel models use the Scrolling Directory:

#### **TX3-120U-C: Electronic Scrolling Directory plus Paper Directory Lobby Control Unit**

- Four-line by 20 character LCD display
- 120 name paper directory
- Main controller board for 200 residents
- PS-4P Transformer
- Universal Enclosure complete with Rain Hood and Light Assembly
- IP capable

#### **TX3-200-8U-C: Eight Line Universal Electronic Scrolling Directory Lobby Control Unit**

- Eight-line by 20 character LCD display
- Main controller board for 200 residents
- PS-4P Transformer
- Universal Enclosure complete with Rain Hood and Light Assembly
- Designed for outdoor applications
- IP capable
- Provision for card reader (sold separately) or postal lock

- Provision for TX3-CX-1NP Single Door Control Module, sold separately

**TX3-1000-8U-C: Eight Line Universal Electronic Scrolling Directory Lobby Control Unit**

- Eight-line by 20 character LCD display
- Main controller board for 1000 residents
- PS-4P Transformer
- Universal Enclosure complete with Rain Hood and Light Assembly
- Designed for outdoor applications
- IP capable
- Provision for card reader (sold separately) or postal lock
- Provision for TX3-CX-1NP Single Door Control Module, sold separately

**TX3-2000-8U-C: Eight Line Universal Electronic Scrolling Directory Lobby Control Unit**

- Eight-line by 20 character LCD display
- Main controller board for 2000 residents
- PS-4P Transformer
- Universal Enclosure complete with Rain Hood and Light Assembly
- Designed for outdoor applications
- IP capable
- Provision for card reader (sold separately) or postal lock
- Provision for TX3-CX-1NP Single Door Control Module, sold separately

**TX3-2000-8UR-C: Reinforced Eight Line Universal Electronic Scrolling Directory Lobby Control Unit**

- Eight-line by 20 character LCD display
- Main controller board for 2000 residents
- PS-4P Transformer
- Reinforced Universal Enclosure complete with Rain Hood and Light Assembly
- Designed for outdoor applications
- IP capable
- Provision for card reader (sold separately) or postal lock
- Provision for TX3-CX-1NP Single Door Control Module, sold separately

### 1.3.2 Universal Slim Line Series

The Universal Slim Line series enclosure houses the following models and can be surface or semi-flush mounted:

#### **TX3-200-4U-C: Slim Line Electronic Scrolling Directory Lobby Control Unit**

- 4 Line by 20 LCD character display
- Main controller board for 200 residents
- PS-4P Transformer
- Universal Slim Line Enclosure complete with Rain Hood and Light Assembly
- IP capable
- Provision for card reader (sold separately) or postal lock
- Provision for TX3-CX-1NP Single Door Control Module, sold separately

#### **TX3-1000-4U-C: Slim Line Electronic Scrolling Directory Lobby Control Unit**

- 4 Line by 20 LCD character display
- Main controller board for 1000 residents
- PS-4P Transformer
- Universal Slim Line Enclosure complete with Rain Hood and Light Assembly
- IP capable
- Provision for card reader (sold separately) or postal lock
- Provision for TX3-CX-1NP Single Door Control Module, sold separately

#### **TX3-2000-4U-C: Slim Line Electronic Scrolling Directory Lobby Control Unit**

- 4 Line by 20 LCD character display
- Main controller board for 2000 residents
- PS-4P Transformer
- Universal Slim Line Enclosure complete with Rain Hood and Light Assembly
- IP capable
- Provision for card reader (sold separately) or postal lock
- Provision for TX3-CX-1NP Single Door Control Module, sold separately

**TX3-2000-4UR-C: Reinforced Slim Line Electronic Scrolling Directory Lobby Control Unit**

- 4 Line by 20 LCD character display
- Main controller board for 2000 residents
- PS-4P Transformer
- Reinforced Universal Slim Line Enclosure complete with Rain Hood and Light Assembly
- IP capable
- Provision for card reader (sold separately) or postal lock
- Provision for TX3-CX-1NP Single Door Control Module, sold separately

**1.3.3 Universal Slim Line Kit**

The Universal Slim Line series is available as a kit:

**TX3-NSL-12K-C.** The TX3-NSL-12K kit consists of:

- TX3-200-4U Slim Line entry panel with speaker and microswitch for postal lock
- 4x20 LCD display
- PS-4P transformer plug
- TX3-NSL-8M Master NSL Relay Cabinet with one PS-4P transformer plug
- 2012K Twelve Telephone Relay Kit with a 2012 Twelve Telephone Relay board and a 9106 Cable
- RJ-71C Punch Down Block for outdoor applications

The Universal Panel Accessories consist of the following:

**TX3-UFT.** Universal Flush mounting trim for use with TX3-120U-C, TX3-200-8U-C, TX3-1000-8U-C and TX3-2000-8U-C. Stainless steel.

**TX3-USFT.** Universal Slim Line Flush mounting trim for TX3-200-4U-C, TX3-1000-4U-C, TX3-2000-4U-C. Stainless steel.

**TX3-UFTR.** Universal Flush mounting trim for use with TX3-2000-8UR-C. Stainless steel.

**TX3-USFTR.** Universal Slim Line Flush mounting trim for TX3-2000-4UR-C. Stainless steel.

### 1.3.4 Continental Series

The Continental Series enclosure for Lobby Control Units are flush mounted and for indoor use only. The following Continental Series models use the Scrolling Directory:

#### **TX3-120C-C: Electronic Scrolling Directory plus Paper Directory Lobby Control Unit**

- Lighted sign box for directory or bulletins
- 4 Line backlit LCD electronic directory
- Flush mount for indoor applications
- Provisions for postal lock and camera

#### **TX3-200-8C-C: Eight Line Continental Electronic Scrolling Directory Lobby Control Unit**

- Eight-line by 20 character LCD display
- Main controller board for 200 residents
- PS-4P Transformer
- Continental Enclosure
- Designed for indoor applications
- IP capable
- Provision for card reader (sold separately) or postal lock
- Provision for TX3-CX-1NP Single Door Control Module, sold separately

#### **TX3-1000-8C-C: Eight Line Continental Electronic Scrolling Directory Lobby Control Unit**

- Eight-line by 20 character LCD display
- Main controller board for 1000 residents
- PS-4P Transformer
- Continental Enclosure
- Designed for indoor applications
- IP capable
- Provision for card reader (sold separately) or postal lock
- Provision for TX3-CX-1NP Single Door Control Module, sold separately

#### **TX3-2000-8C-C: Eight Line Continental Electronic Scrolling Directory Lobby Control Unit**

- Eight-line by 20 character LCD display
- Main controller board for 2000 residents



- PS-4P Transformer
- Continental Enclosure
- Designed for indoor applications
- IP capable
- Provision for card reader (sold separately) or postal lock
- Provision for TX3-CX-1NP Single Door Control Module, sold separately

#### **TX3-2000-8CR-C: Reinforced Eight Line Continental Electronic Scrolling Directory Lobby Control Unit**

- Eight-line by 20 character LCD display
- Main controller board for 2000 residents
- PS-4P Transformer
- Reinforced Continental Enclosure
- Designed for indoor applications
- IP capable
- Provision for card reader (sold separately) or postal lock
- Provision for TX3-CX-1NP Single Door Control Module, sold separately

## **1.4 Lobby Control Unit Accessories**

The Lobby Control Unit accessories consist of the following items:

- TX3-NSL-8M Master NSL Relay Cabinet
- TX3-UFT Universal series flush trim ring
- TX3-USFT Universal Slim Line Series flush trim ring
- TX3-UFTR Universal Flush mounting trim for use with TX3-2000-8UR-C
- TX3-USFTR Universal Slim Line Flush mounting trim for TX3-2000-4UR-C
- TX3-UGA Gooseneck mounting adapter designed for use with the standard Universal Series enclosure for pedestals
- TX3-USGA Gooseneck mounting adapter designed for use with the TX3-200-4U Universal Slim Line enclosure pedestals
- TH-102 Thermostat Heater with one PS-24P Transformer Plug
- CAM-3 TX3 Camera
- TX3-MDM Modem Module
- TX3-GPM Guard Phone Module

- TX3-USB-AD USB to RS-485 Adapter
- TX3-IP IP Module
- TX3-P300-HA Mullion mount card reader. Fits inside panel
- TX3-CX-1NP Single Door Control Module, PoE, 12 VDC, 24-48 VDC
- TX3-WIEGAND-OUT Wiegand output module
- TX3-BB-C Backbox for the continental enclosure
- TX3-BBR-C Backbox for the reinforced continental enclosure

## 1.5 Maximum and Minimum Mounting Heights to Comply with the ADA (Americans with Disabilities Act)

To comply with section 308.2.1 of the 2010 ADA Standards for Accessible Design, the maximum and minimum mounted heights for lobby control units are shown in the table below.

<b>Model</b>	<b>Maximum distance from the finished floor to the lowest part of the unit</b>	<b>Minimum distance from the finished floor to the lowest part of the unit</b>
TX3-120U-C	1132 mm (44 9/16")	356 mm (14 1/16")
TX3-120C-C	1109 mm (43 11/16")	333 mm (13 1/8")
TX3-200-4U-C, TX3-1000-4U-C, TX3-2000-4U-C	974 mm (38 3/8")	197 mm (7 3/4")
TX3-200-8U-C, TX3-1000-8U-C, TX3-2000-8U-C	970 mm (38 3/16")	193 mm (7 5/8")
TX3-200-8C-C, TX3-1000-8C-C, TX3-2000-8C-C	944 mm (37 3/16")	168 mm (6 5/8")
TX3-2000-4UR-C	968 mm (38 1/8")	191 mm (7 1/2")
TX3-2000-8UR-C	964 mm (37 15/16")	187 mm (7 3/8")
TX3-2000-8CR-C	931 mm (36 11/16")	155 mm (6 1/8")

## 1.6 Mounting requirements from the 2010 ADA Standards for Accessible Design

See <http://www.ada.gov/> for more information.

### 308.2 Forward Reach.

**308.2.1 Unobstructed.** Where a forward reach is unobstructed, the high forward reach shall be 48 inches (1220 mm) maximum and the low forward reach shall be 15 inches (380 mm) minimum above the finish floor or ground.

**308.2.2 Obstructed High Reach.** Where a high forward reach is over an obstruction, the clear floor space shall extend beneath the element for a distance not less than the required reach depth over the obstruction. The high forward reach shall be 48 inches (1220 mm) maximum where the reach depth is 20 inches (510 mm) maximum. Where the reach depth exceeds 20 inches (510 mm), the high forward reach shall be 44 inches (1120 mm) maximum and the reach depth shall be 25 inches (635 mm) maximum.

### 308.3 Side Reach.

**308.3.1 Unobstructed.** Where a clear floor or ground space allows a parallel approach to an element and the side reach is unobstructed, the high side reach shall be 48 inches (1220 mm) maximum and the low side reach shall be 15 inches (380 mm) minimum above the finish floor or ground.

#### EXCEPTIONS:

1. An obstruction shall be permitted between the clear floor or ground space and the element where the depth of the obstruction is 10 inches (255 mm) maximum.
2. Operable parts of fuel dispensers shall be permitted to be 54 inches (1370 mm) maximum measured from the surface of the vehicular way where fuel dispensers are installed on existing curbs.

**308.3.2 Obstructed High Reach.** Where a clear floor or ground space allows a parallel approach to an element and the high side reach is over an obstruction, the height of the obstruction shall be 34 inches (865 mm) maximum and the depth of the obstruction shall be 24 inches (610 mm) maximum. The high side reach shall be 48 inches (1220 mm) maximum for a reach depth of 10 inches (255 mm) maximum. Where the reach depth exceeds 10 inches (255 mm), the high side reach shall be 46 inches (1170 mm) maximum for a reach depth of 24 inches (610 mm) maximum.

#### EXCEPTIONS:

1. The top of washing machines and clothes dryers shall be permitted to be 36 inches (915 mm) maximum above the finish floor.
2. Operable parts of fuel dispensers shall be permitted to be 54 inches (1370 mm) maximum measured from the surface of the vehicular way where fuel dispensers are installed on existing curbs.

## 1.7 About This Manual

This manual provides comprehensive information on the installation and configuration of the TX3 Series Telephone Access System by the installation technician. Tasks are described in the order that they are likely to be performed.

### 1.7.1 Additional Documentation

For additional documentation, see the following Mircom literature:

- LT-995 Touch Screen Administrators Guide
- LT-980 TX3-CX Card Access System Installation and Operation Manual
- LT-6618 TX3-CX-1 Installation Manual
- LT-1160 TX3-CX-A8 Aperio Interface Panel Installation and Operation Manual
- LT-9940 TX3 Elevator Restriction Installation and Operation Manual
- LT-968 TX3 Telephone Access System User's Guide
- TX3 Two Door Card Access System Kit Catalogue Number 6531

## 1.8 Warranty and Special Notices

Mircom values your business and always attempts to provide you with the very best service.

Please see the Warranty chapter on page 102 and Special Notices on page 107 for information about the warranty and special notices about equipment use.

## 1.9 Contact Us

### 1.9.1 Canada and USA

**Toll Free:** 1-888-660-4655

**Local:** 905-660-4655

**Fax:** 905-660-4113

### 1.9.2 Website

<http://www.mircom.com>

# 2 Enclosure Installation

This chapter provides information on how to install the various enclosures and panels.

## This chapter explains

- Ground the Telephone Access System
- Install the Enclosures and Lobby Control Unit
- Install the Heater

## 2.1 Ground the Telephone Access System

Grounding reduces the risk of electrical shock by providing an alternate escape route for the electrical current. Telephone Access System is equipped with a 16 gauge electrical wire attached to the panel chassis ground post.

To ground the Telephone Access System attach one end of the supplied cable to a suitable grounding wire and connect it to the site ground.

## 2.2 Install the Enclosures and Lobby Control Unit

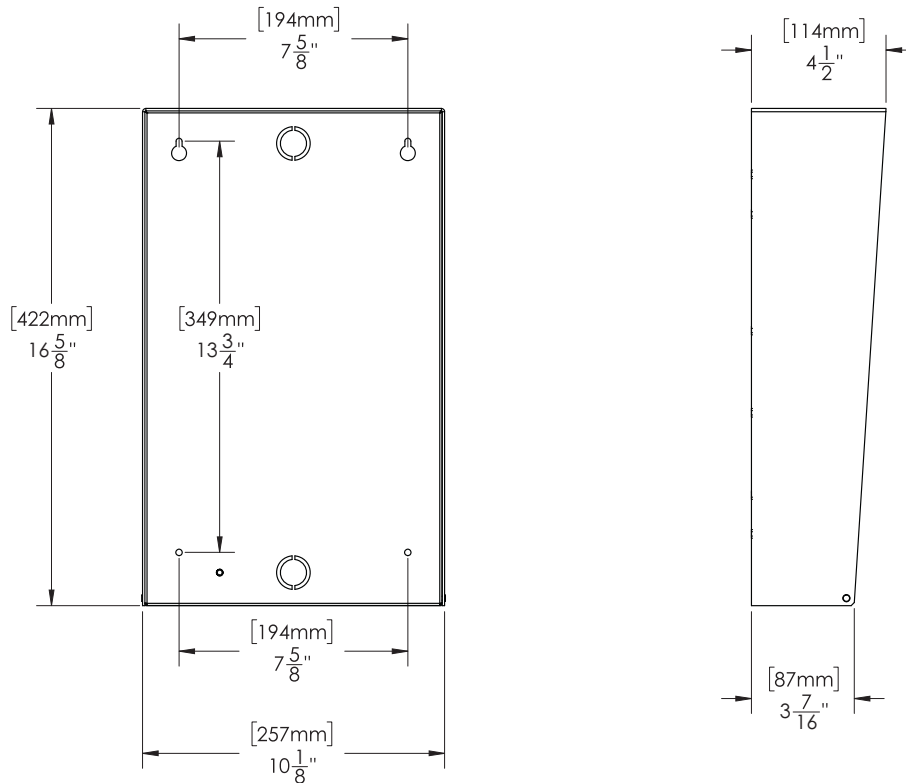
Lobby Control Units use one of the following three types of Lobby Control Unit enclosures:

**Universal Series.** The Universal Series are surface or semi-flush mounted with the lobby Lobby Control Units. Optional flush trim rings are available for semi-flush and flush installations. The semi-flush trim is the TX3-UFT or TX3-UFTR for reinforced models. A rain hood is included allowing for outdoor use.

**Universal Slim Line Series.** The Universal Slim Line series enclosure can be surface or semi-flush mounted. The semi-flush trim is the TX3-USFT or TX3-USFTR for reinforced models.

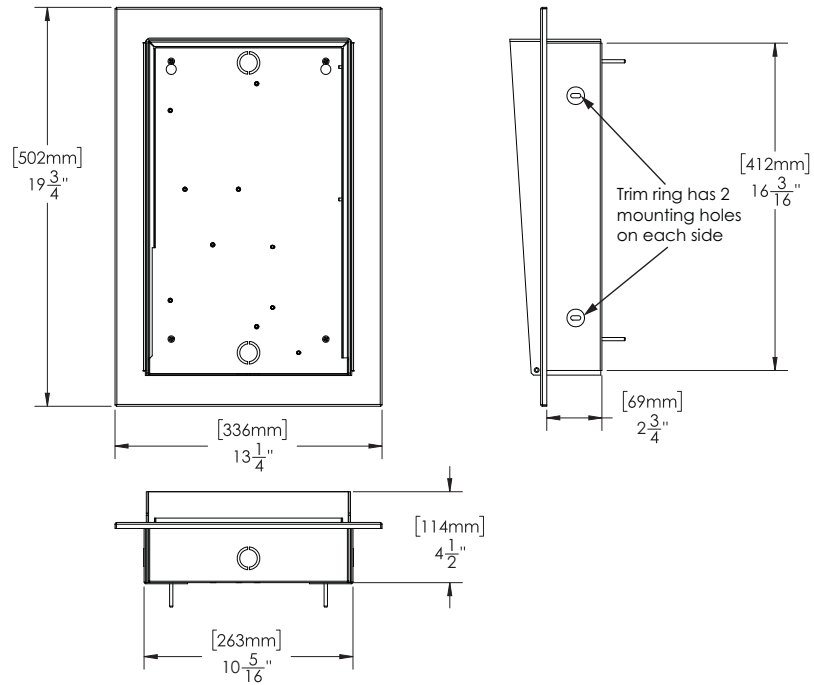
**Continental Series.** The Continental Series enclosure for Lobby Control Units are flush mounted.

### 2.2.1 Install the Universal Enclosure

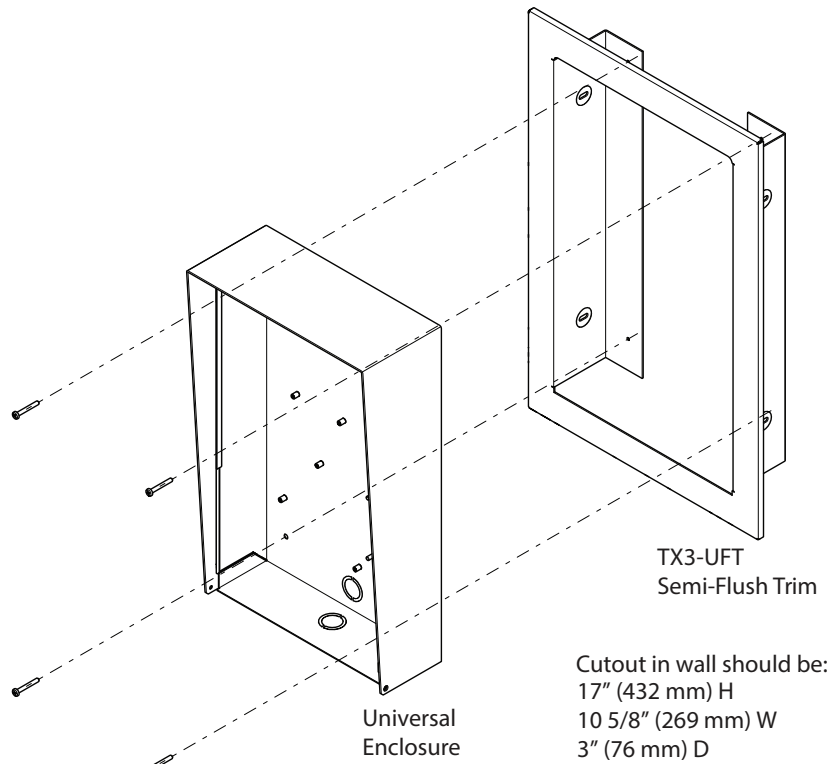


**Figure 1 TX3-200-8U-C, TX3-1000-8U-C, TX3-2000-8U-C, TX3-120U-C Dimensions**

The Universal enclosure mounts inside the wall with or without the TX3-UFT Universal Series Flush Trim Ring TX3-UFT. This Trim Ring houses the universal series enclosure as shown in figure 3.



**Figure 2 Dimensions of TX3-UFT and the Universal Enclosure**



**Figure 3 Mount TX3-UFT Universal Series Flush Trim Ring**

### Flush mount the Universal Enclosure with the trim ring

1. Find a suitable location for the enclosure.
2. Cut an opening in the wall. The dimensions of the cutout are shown in figure 3.
3. Insert the trim ring into the wall cutout.
4. Attach the trim ring to vertical supports using four appropriate fasteners. The mounting holes are shown in figure 2.

---

**Note:** Install the trim ring with the arrow pointing up.

---

---

**Note:** If you are mounting the trim ring to a wall stud, attach one side to the wall stud with appropriate fasteners, and leave the other side free.

---

5. Insert the universal enclosure with the rain hood inside the trim ring.
6. Secure the universal enclosure inside the trim ring using the four included screws as shown in figure 3.

### Surface mount the Universal Enclosure without the trim ring

1. Find a suitable location for the enclosure.
2. Using the enclosure as a template, mark the mounting hole locations as indicated in figure 1.
3. Attach the enclosure to the wall with appropriate fasteners at the marked hole locations.

---

**Note:** If you are mounting the enclosure on a wall stud, use drywall anchors on the side that is not over the stud.

---

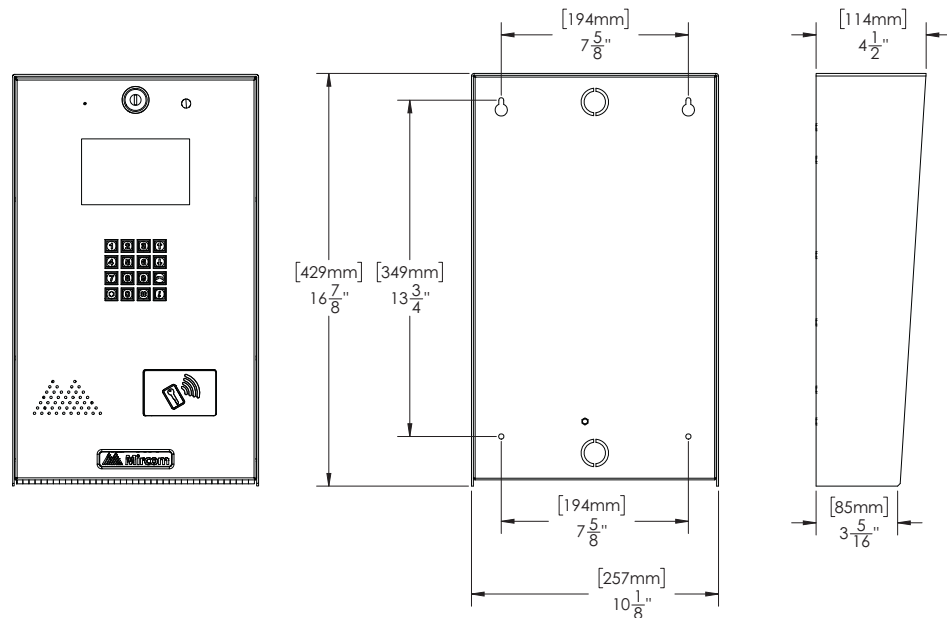
---

**Note:** The enclosure can also be mounted directly onto the drywall using anchors.

---

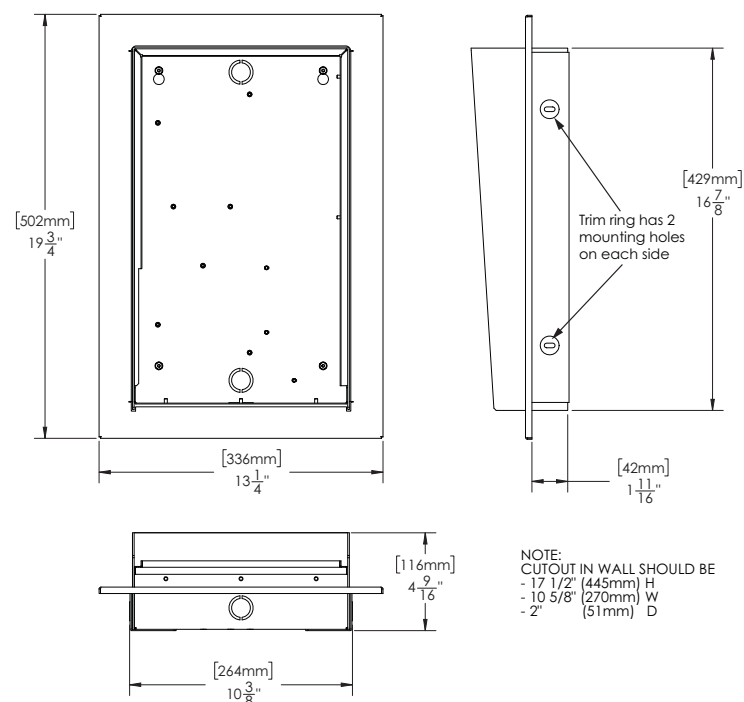


## 2.2.2 Install the Reinforced Universal Enclosure

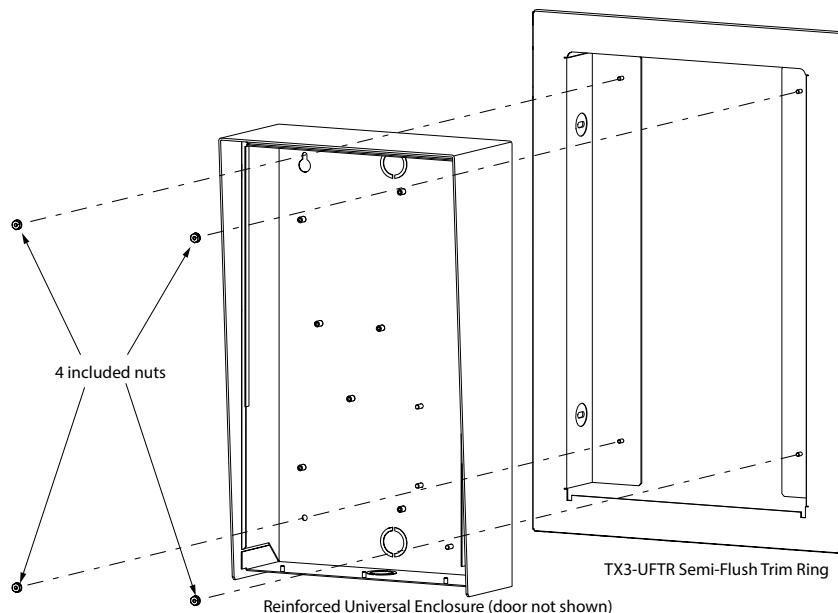


**Figure 4 Dimensions of TX3-2000-8UR-C**

The reinforced universal enclosure mounts on the wall or inside the wall with or without the TX3-UFTR semi-flush trim ring for reinforced universal enclosures. This trim ring houses the universal series enclosure as shown in figures 5 and 6.



**Figure 5 Dimensions of TX3-2000-8UR-C with TX3-UFTR**



**Figure 6** Mount TX3-2000-8UR-C into TX3-UFTR

### Flush mount the Reinforced Universal Enclosure with the trim ring

1. Find a suitable location for the enclosure.
2. Cut an opening in the wall. The dimensions of the cutout are shown in figure 5.
3. Insert the trim ring into the wall cutout.
4. Attach the trim ring to vertical supports using four appropriate fasteners. The mounting holes are shown in figure 5.

---

**Note:** Install the trim ring with the arrow pointing up.

---

**Note:** If you are mounting the trim ring to a wall stud, attach one side to the wall stud with appropriate fasteners, and leave the other side free.

---

5. Insert the universal enclosure with the rain hood inside the trim ring.
6. Secure the universal enclosure inside the trim ring using the four included nuts as shown in figure 6.

### Surface mount the Reinforced Universal Enclosure without the trim ring

1. Find a suitable location for the enclosure.
2. Using the enclosure as a template, mark the mounting hole locations as indicated in figure 4.
3. Attach the enclosure to the wall with appropriate fasteners at the marked hole locations.

---

**Note:** If you are mounting the enclosure on a wall stud, use drywall anchors on the side that is not over the stud.

---

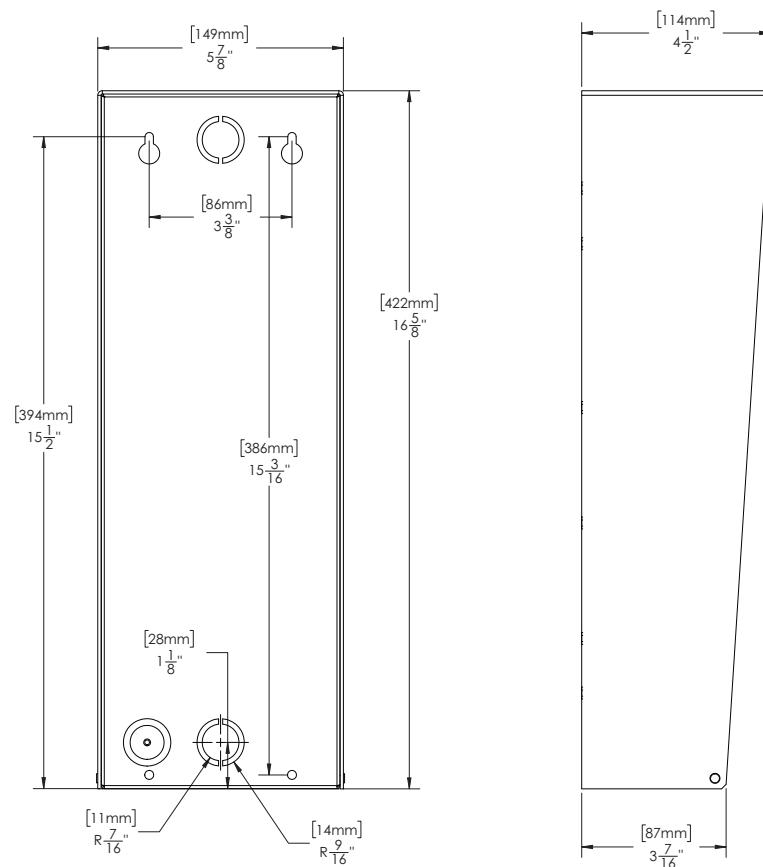


---

**Note:** The enclosure can also be mounted directly onto the drywall using anchors.

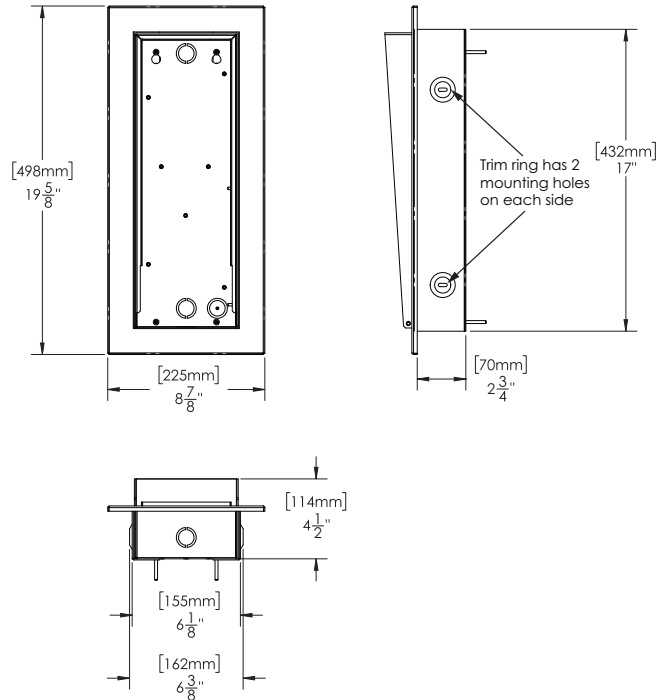
---

### 2.2.3 Install the Universal Slim Line Enclosure

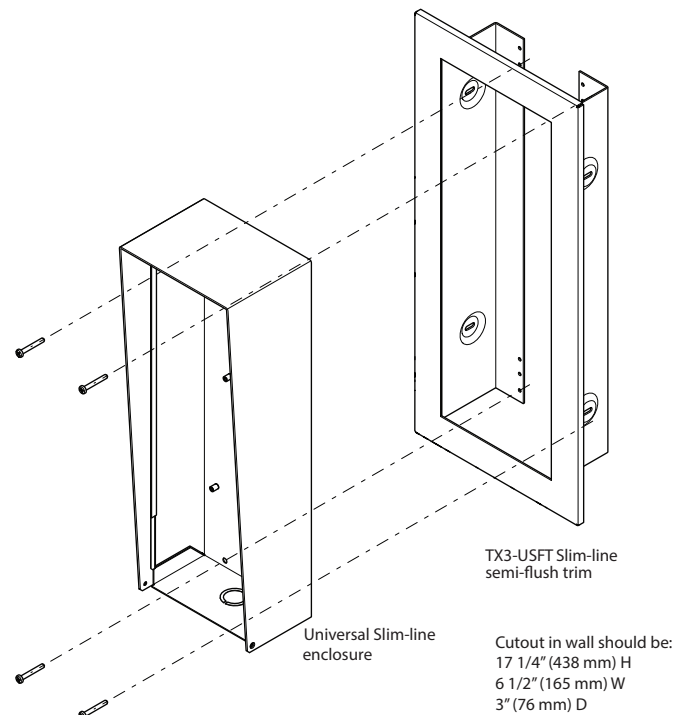


**Figure 7** TX3-200-4U-C, TX3-1000-4U-C, TX3-2000-4U-C Dimensions

The Universal enclosure mounts inside the wall with or without the Universal Slim Line Series Flush Trim Ring TX3-USFT. The Trim Ring houses the universal series enclosure as shown in figure 9.



**Figure 8 Dimensions of TX3-USFT and the Universal Slim Line Enclosure**



**Figure 9** Mount TX3-USFT Universal Slim Line Flush Trim Ring

### Flush mount the Universal Slim Line Enclosure with the trim ring

1. Find a suitable location for the enclosure.
2. Cut an opening in the wall. The dimensions of the cutout are shown in figure 9.
3. Insert the trim ring into the wall cutout.
4. Attach the trim ring to vertical supports using four appropriate fasteners. The mounting holes are shown in figure 8.

---

**Note:** Install the trim ring with the arrow pointing up.

---



---

**Note:** If you are mounting the trim ring to a wall stud, attach one side to the wall stud with appropriate fasteners, and leave the other side free.

---

5. Insert the universal enclosure with the rain hood inside the trim ring.
6. Secure the universal enclosure inside the trim ring using the four included screws as shown in figure 9.

### Surface mount the Universal Slim Line Enclosure without the trim ring

1. Find a suitable location for the enclosure.
2. Using the enclosure as a template, mark the mounting hole locations as indicated in figure 7.
3. Attach the enclosure to the wall with appropriate fasteners at the marked hole locations.

---

**Note:** If you are mounting the enclosure on a wall stud, use drywall anchors on the side that is not over the stud.

---

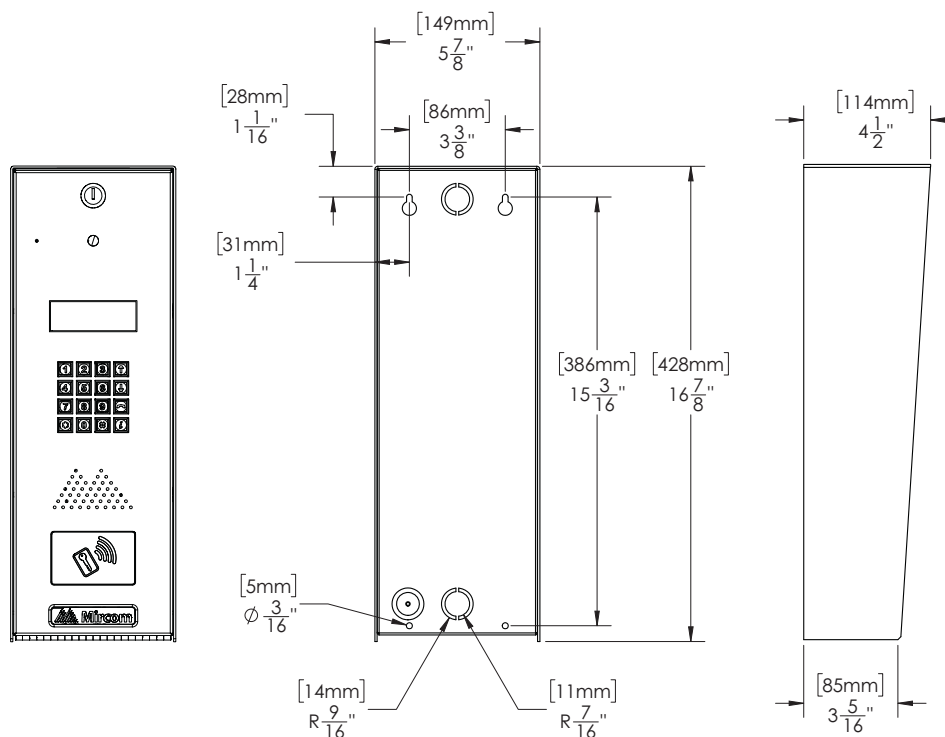


---

**Note:** The enclosure can also be mounted directly onto the drywall using anchors.

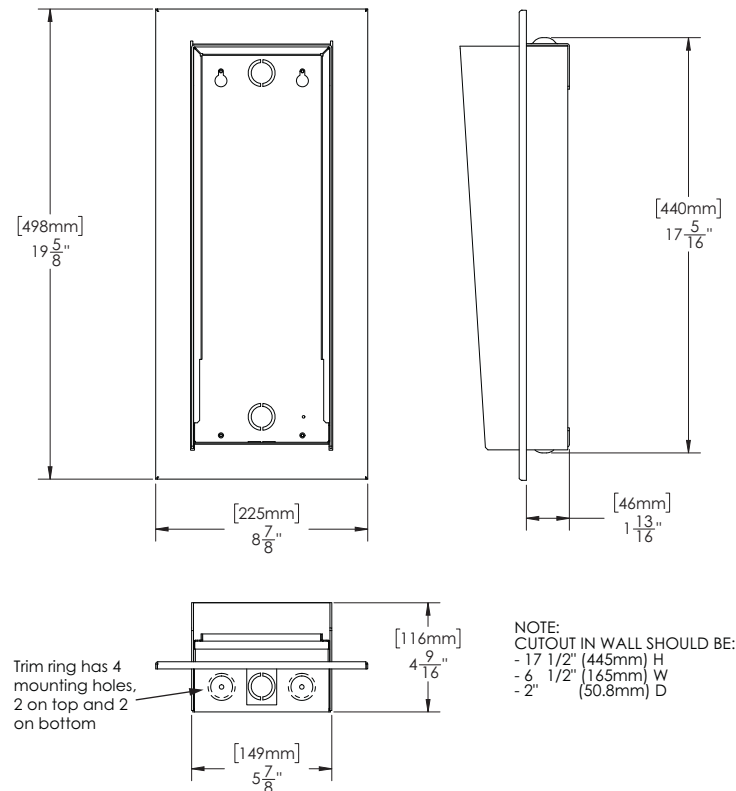
---

#### 2.2.4 Install the Reinforced Universal Slim Line Enclosure

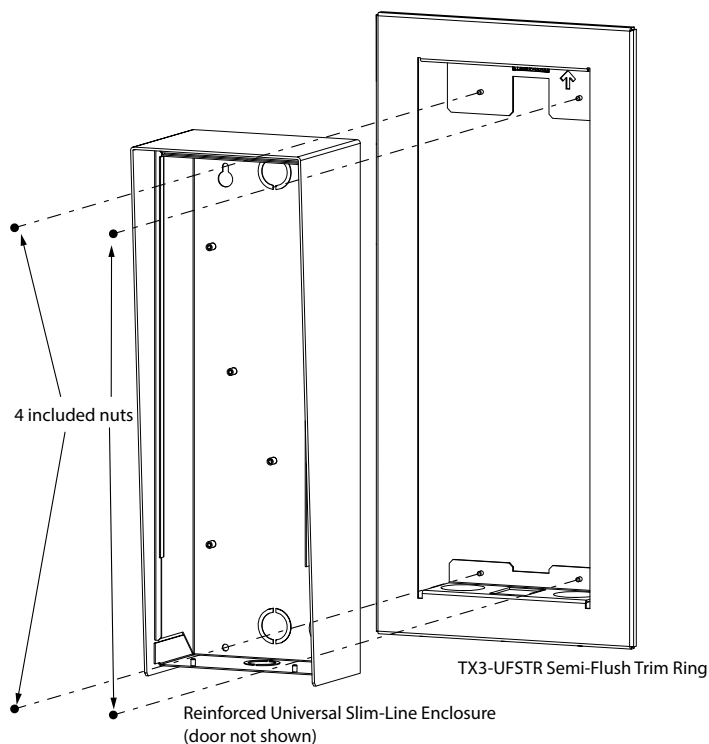


**Figure 10** Dimensions of TX3-2000-4UR-C

The reinforced Universal Slim Line enclosure mounts on the wall or inside the wall with or without TX3-USFTR the semi-flush trim ring for reinforced Universal Slim Line enclosures. The trim ring houses the Universal series enclosure as shown in figures 11 and 12.



**Figure 11** Dimensions of TX3-2000-4UR-C with TX3-USFTR



**Figure 12** Mount TX3-USFTR Semi-Flush Trim Ring for Reinforced Universal Slim Line Enclosures (door not shown)

### Flush mount the Reinforced Universal Slim Line Enclosure with the trim ring

1. Find a suitable location for the enclosure.
2. Cut an opening in the wall. The dimensions of the cutout are shown in figure 11.
3. Insert the trim ring into the wall cutout.
4. Attach the trim ring to horizontal supports using four appropriate fasteners. The mounting holes are on the top and bottom of the trim ring. They are shown in figure 11.

---

**Note:** Install the trim ring with the arrow pointing up.

---

5. Insert the universal enclosure with the rain hood inside the trim ring.
6. Secure the universal enclosure inside the trim ring using the four included nuts as shown in figure 12.



### Surface mount the Reinforced Universal Slim Line Enclosure without the trim ring

1. Find a suitable location for the enclosure.
2. Using the enclosure as a template, mark the mounting hole locations as indicated in figure 10.
3. Attach the enclosure to the wall with appropriate fasteners at the marked hole locations.

---

**Note:** If you are mounting the enclosure on a wall stud, use drywall anchors on the side that is not over the stud.

---



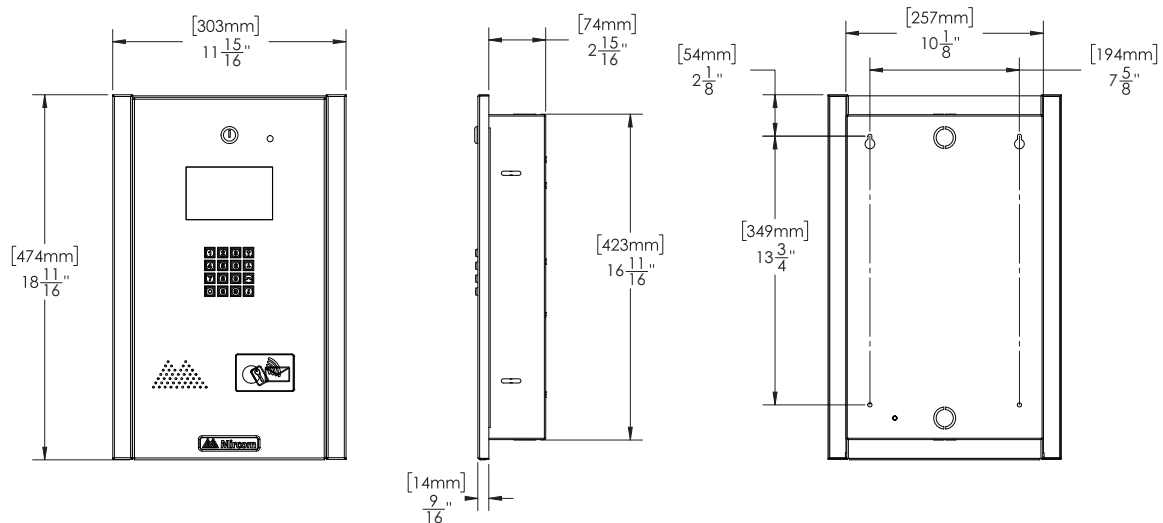
---

**Note:** The enclosure can also be mounted directly onto the drywall using anchors.

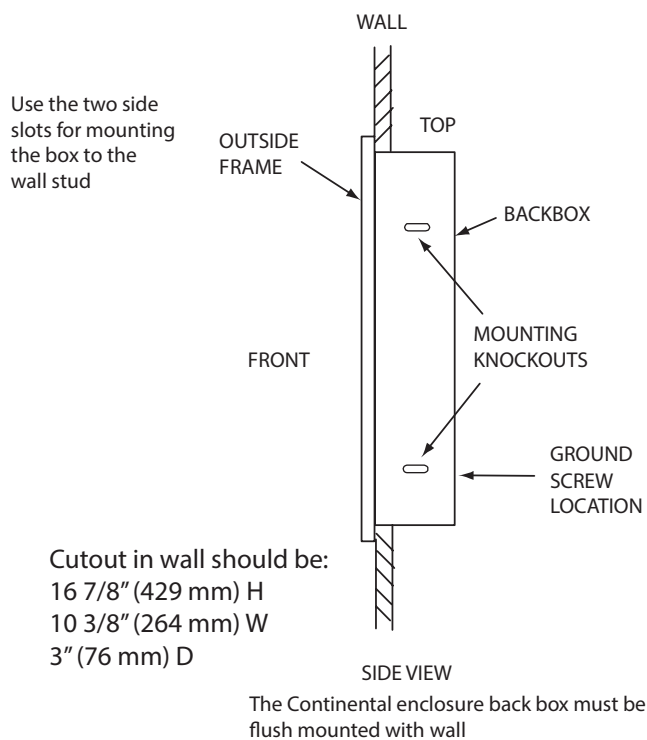
---

## 2.2.5 Install the Continental Enclosure

The Continental enclosure flush mounts directly inside the wall to the wall stud as shown in figure 14. Mount the back box flush with the wall and right-side up (the ground screw location is at the bottom).



**Figure 13** TX3-200-8C-C, TX3-1000-8C-C, TX3-2000-8C-C, TX3-120C-C  
Dimensions



**Figure 14 Mount the Continental Enclosure**

### Install the Continental Enclosure

1. Find a suitable location for the enclosure.
2. Cut an opening in the wall. The dimensions of the cutout are shown in figure 14.
3. Insert the enclosure into the wall cutout.

---

**Note:** Install the enclosure right-side up (the ground screw is on the bottom).

---

4. Attach the enclosure to the supports using four appropriate fasteners. The mounting holes are shown in figure 13 and figure 14.

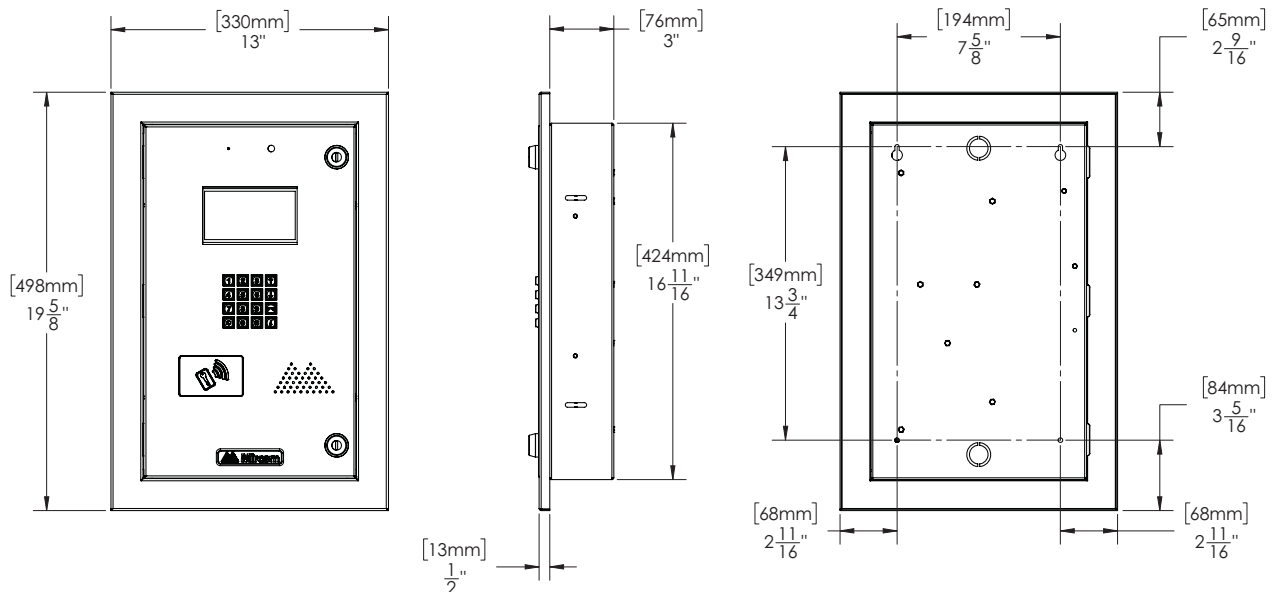
---

**Note:** If you are mounting the enclosure to a wall stud, attach one side to the wall stud with appropriate fasteners, and leave the other side free.

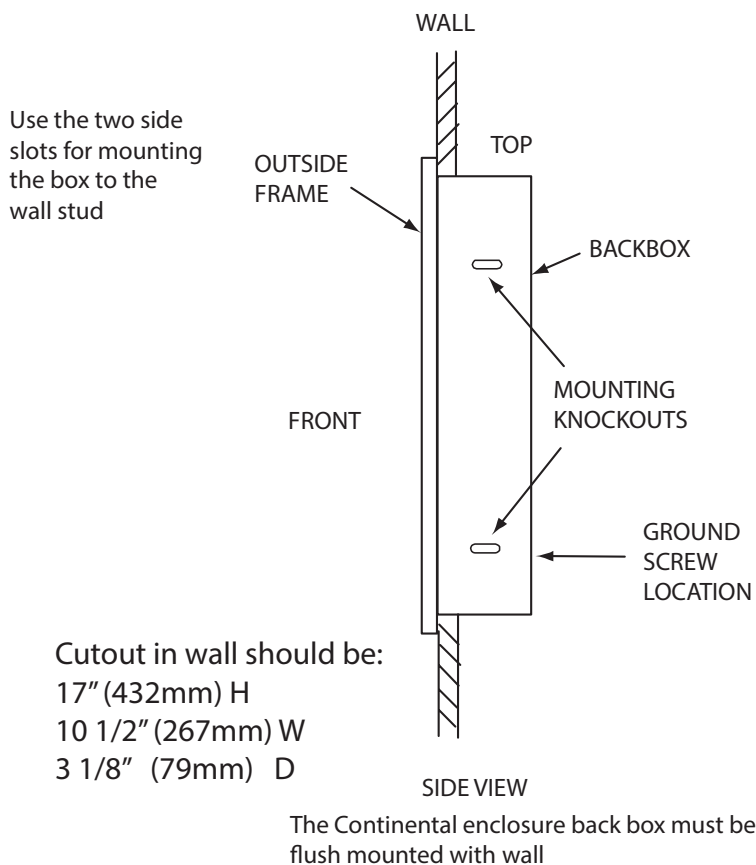
---

## 2.2.6 Install the Reinforced Continental Enclosure

The reinforced continental enclosure flush mounts directly inside the wall to the wall stud as shown in figure 16. Mount the enclosure flush with the wall and right-side up (the ground screw location is at the bottom).



**Figure 15 Dimensions of TX3-2000-8CR-C**



**Figure 16 Mount TX3-2000-8CR-C**

### Install the Reinforced Continental Enclosure

1. Find a suitable location for the enclosure.
2. Cut an opening in the wall. The dimensions of the cutout are shown in figure 16.
3. Insert the enclosure into the wall cutout.

---

**Note:** Install the enclosure right-side up (the ground screw is on the bottom).

---

- Attach the enclosure to the supports using four appropriate fasteners. The mounting holes are shown in figure 15 and figure 16.

---

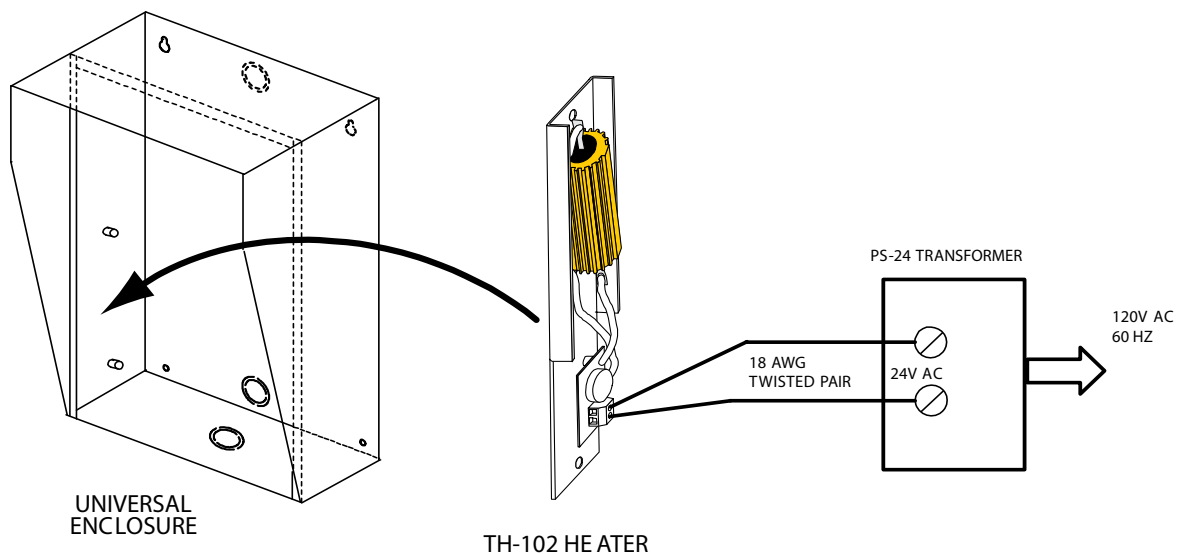
**Note:** If you are mounting the enclosure to a wall stud, attach one side to the wall stud with appropriate fasteners, and leave the other side free.

---

## 2.3 Install the Heater

For temperatures where the Telephone Access System operates below 0 °C (32 °F) at any time, a heater must be installed inside the Universal enclosure as shown in figure 17.

For additional information refer to LT-653 TH-102 Heater Installation Instructions.



**Figure 17 Heater TH-102 Installation Location**

### Install the heater

- Place the TH-102 Heater into the bottom left hand corner of the Universal enclosure and secure using the two supplied spacers and two hex nuts.
- Connect the TH-102 heater to the PS-24 Transformer 24 Vac terminal screws using a pair of #18 AWG wires.

---

**Note:** The transformer must be installed outside the enclosure.

---

# 3 TX3 System

This chapter provides information about the TX3 System and its use.

## This chapter explains

- TX3 System
- Single Lobby Control Unit
- Dual Lobby Control Units
- Three Lobby Control Unit Configuration
- Multiple Lobby Control Units
- Networking TX3 Panels
- Lobby Control Unit Wiring

## 3.1 TX3 System

The TX3 Lobby Control Unit may be networked with a combination of Elevator Restriction Units and Card Access Units through a peer-to-peer RS-485 connection.

The TX3 system is capable of providing ADC or NSL telephone access from a single panel or from a networked system.

The No Subscriber Line (NSL) controller does not require an outside telephone service and calls residents directly using the existing building's resident telephone lines. The NSL system uses the TX3-NSL-8M NSL units and TX3-8EC/16 NSL expanders situated in the electrical/telephone rooms.

The Auto Dialer Controller (ADC) uses the existing outside telephone lines to call residents.

Each outside telephone line requires a separate line to the entry control panel.

The following figures depict various TX3 network scenarios.

---

**Note:** Install all transformers outside the Lobby Control Unit enclosure.

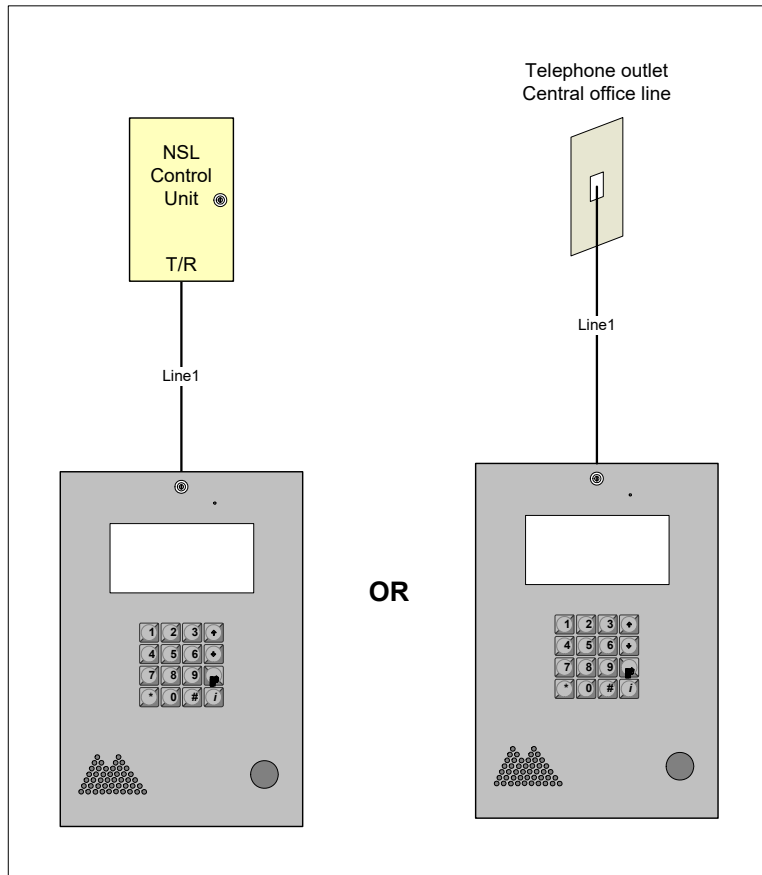
---

All wiring is a maximum length of 1000 ft. The RS-485 wiring maximum length is 4000 ft.

All units use the PS-4P transformer for the power supply. The door strike power supply depends on the door strike power requirements.

### 3.2 Single Lobby Control Unit

Figure 18 shows the simplest configuration.



**Figure 18. Single Lobby Control Unit**

Figure 19 shows a configuration using one Lobby Control Unit connected to one ADC line and four NSL lines.

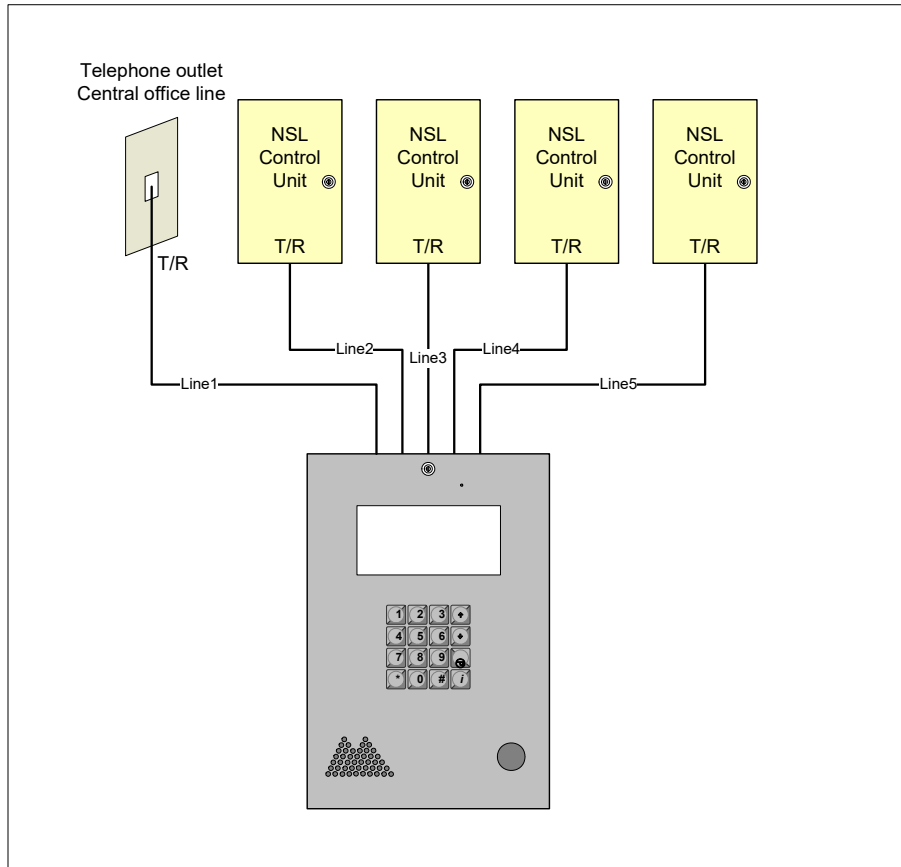


Figure 19. Single Lobby Control Unit with ADC and NSL Lines



Figure 20 shows the various inputs to the panels.

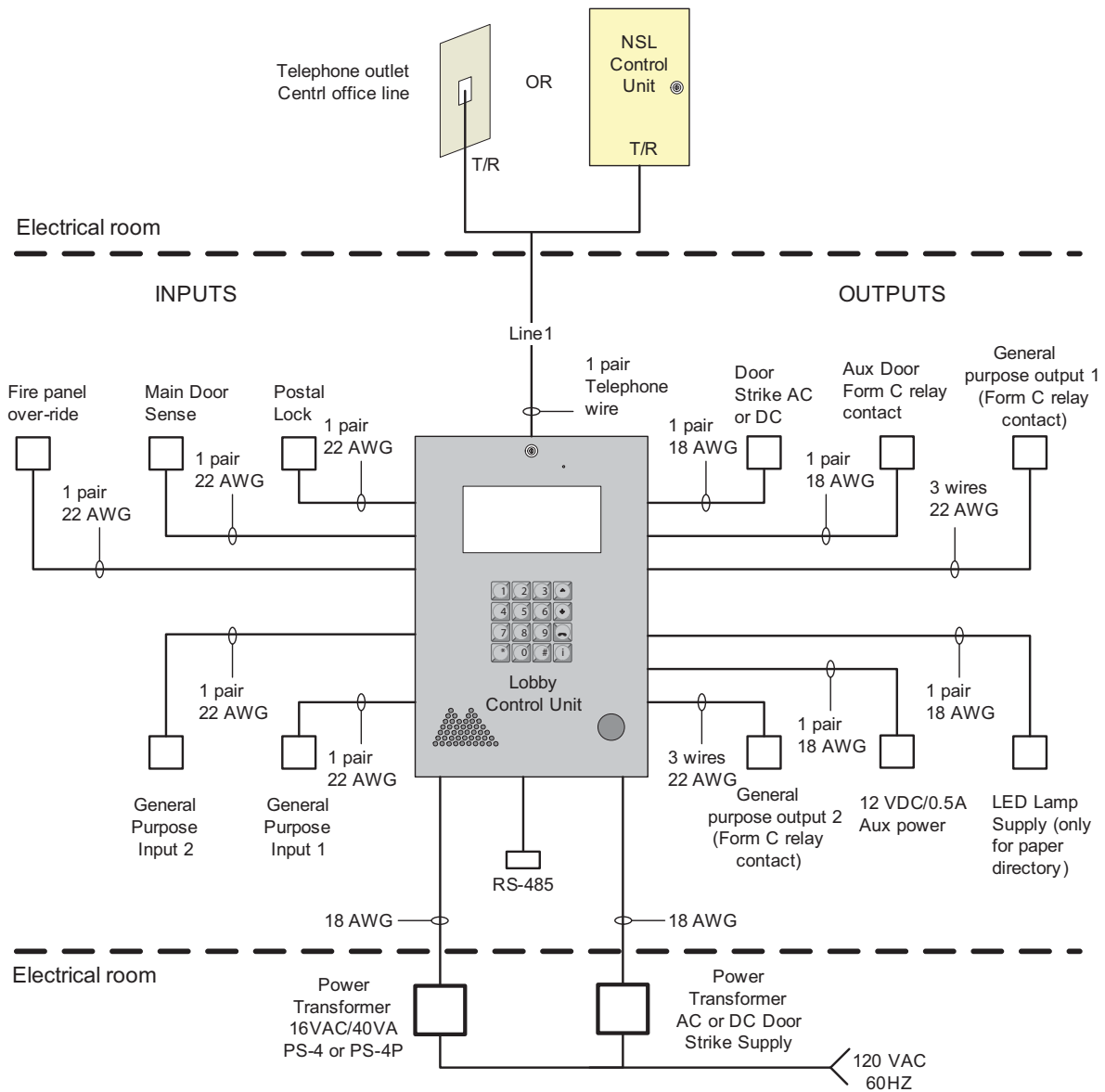


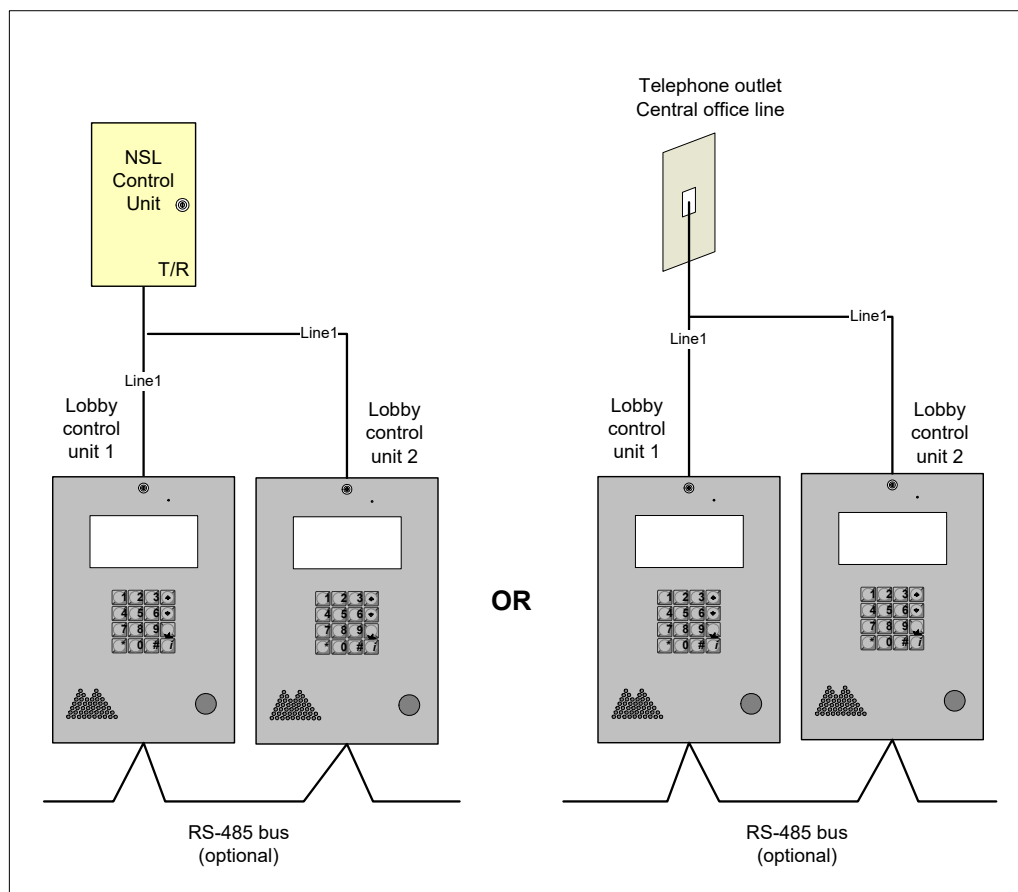
Figure 20. Single Entrance System Wiring

### 3.3 Dual Lobby Control Units

Figure 21 shows a dual entry application for either an NSL type or ADC connection type. The phone line from either the NSL control unit or an ADC dedicated phone line is shared by both Lobby Control Units.

The Lobby Control Unit senses whether the line is in use. If one of the Lobby Control Units is in use and the user tries to make a call, the other lobby indicates that the line is in use.

The RS-485 network connection is optional and is only required if the user decides to connect a PC configurator on one of the panels to configure and/or monitor both systems.



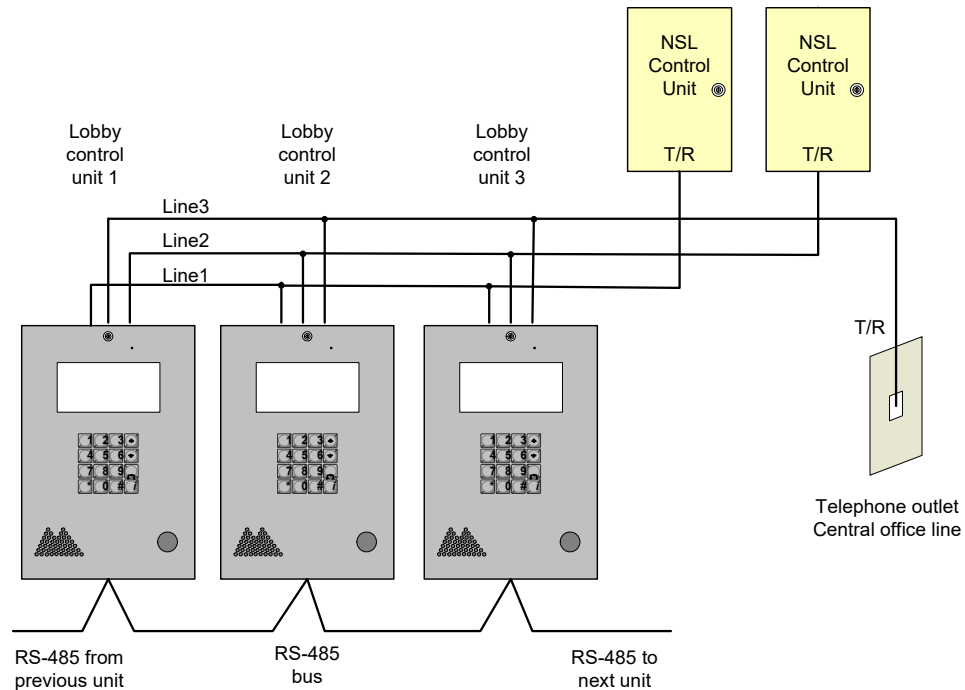
**Figure 21. Dual Lobby Control Units**

### 3.4 Three Lobby Control Unit Configuration

Figure 22 shows a configuration with many Lobby Control Units connected to many phone lines using combined ADC and NSL connection types. Line 1 and Line 2 connect to NSL Control Units while Line 3 connects to a dedicated phone line.

Lobby Control Units 1, 2 and 3 can make simultaneous calls as long as a line is not in use by another Lobby Control Unit. For example, if Lobby Control Unit 1 uses line1, Lobby Control Unit 2 can use Line 2 and Lobby Control Unit 3 can use line 3.

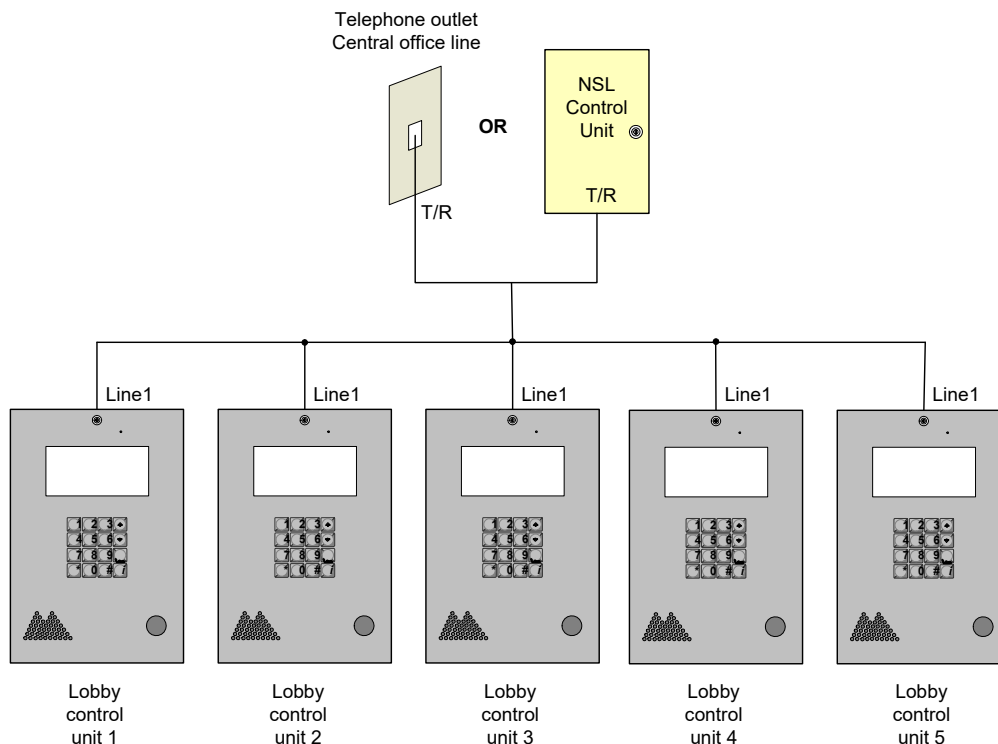
When Lobby Control Unit 1 is using line 1 and Lobby Control Unit 2 also wants to use line1, which is busy, then a line busy message displays on Lobby Control Unit 2.



**Figure 22. Multiple Lobby Control Units to Multiple Lines**

## 3.5 Multiple Lobby Control Units

Figure 23 shows a configuration of many Lobby Control Units to one phone line. The phone can be either a dedicated phone line from the phone company or an NSL phone line from the NSL Control Unit.



**Figure 23. Many Lobby Control Units to One Line**

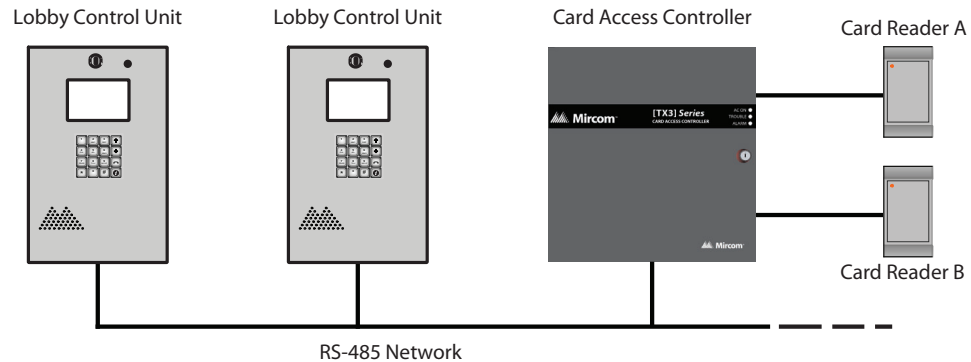
## 3.6 Networking TX3 Panels

Mircom devices such as the Lobby Control Unit, the Card Access Controller, and the Touch Screen can be networked with the TX3 system through a peer-to-peer RS-485 network, an Ethernet TCP/IP network, or a combination of Ethernet and RS-485 networks.

The TX3 Configurator software can connect to any of these network configurations. How you connect to the network (that is, through TCP/IP, USB, a modem, or the COM port) determines what devices you can configure on the network using the TX3 Configurator. The different network configurations are explained in the rest of this section.

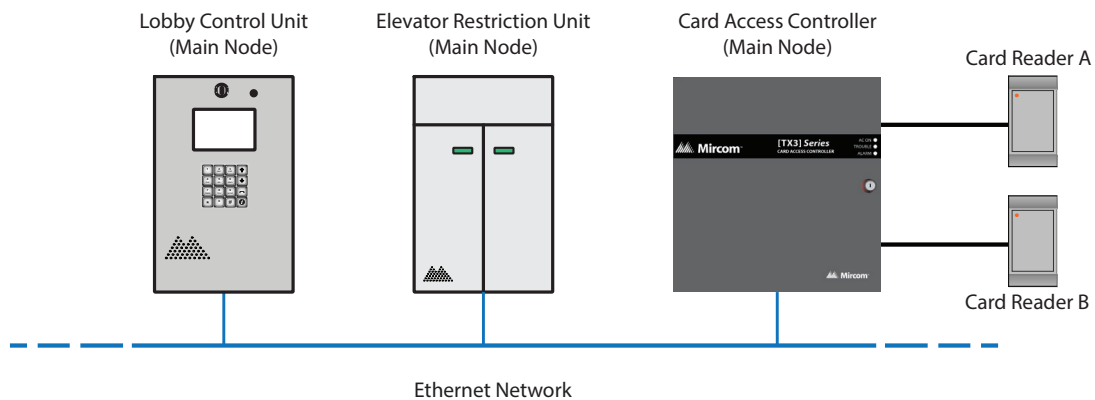
Figure 24 shows a configuration with TX3 controllers connected on an RS-485 network. Each controller has to have a unique network address on the RS-485 network. Up to 63 unique network addresses can be assigned. If you connect to

any device on the RS-485 network (using USB, a modem, or the COM port), you can also connect to and configure any other device on the RS-485 network using the TX3 Configurator.



**Figure 24. TX3 devices on an RS-485 network.**

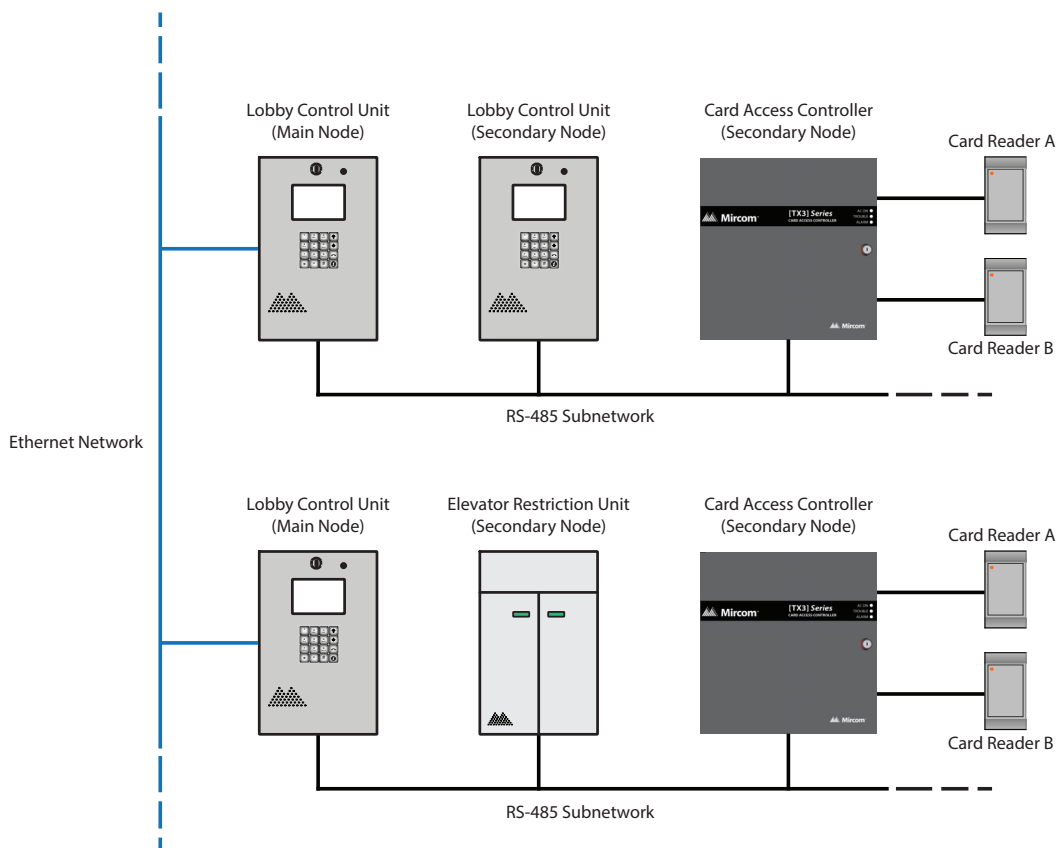
Figure 25 shows a configuration with TX3 devices connected to an Ethernet TCP/IP network. This configuration removes the 63 device limitation that you have on an RS-485 network. The devices connected to an Ethernet TCP/IP network are called Main Nodes. If you connect to the TCP/IP network with the TX3 Configurator, you can connect to and configure any of the Main Nodes on the Ethernet TCP/IP network. If you connect directly to one of the Main Nodes using USB, a modem, or a COM port, you will be able to configure that device but not any other device.



**Figure 25. TX3 devices on an Ethernet TCP/IP network.**

- Notes:**
- In order for a panel to connect to an Ethernet TCP/IP network:
    - it must have a TX3-IP IP Module installed, if it is not a Touch Screen.

Figure 26 shows a configuration with TX3 devices connected on both an Ethernet TCP/IP network and on RS-485 subnetworks. Devices connected to a Main Node's RS-485 subnetwork are Secondary Nodes to the Main Node. Each RS-485 subnetwork can have up to 63 devices connected to it; you can still have more than 63 Main Nodes connected to the Ethernet network.



**Figure 26. Lobby control units using both Ethernet and RS-485 networks**

If you connect to the Ethernet TCP/IP network with the TX3 Configurator, you can configure any of the nodes in this configuration. If you connect directly to a device using USB, a modem, or a COM port, you will only be able to configure devices that are on the same RS-485 subnetwork as that device.

---

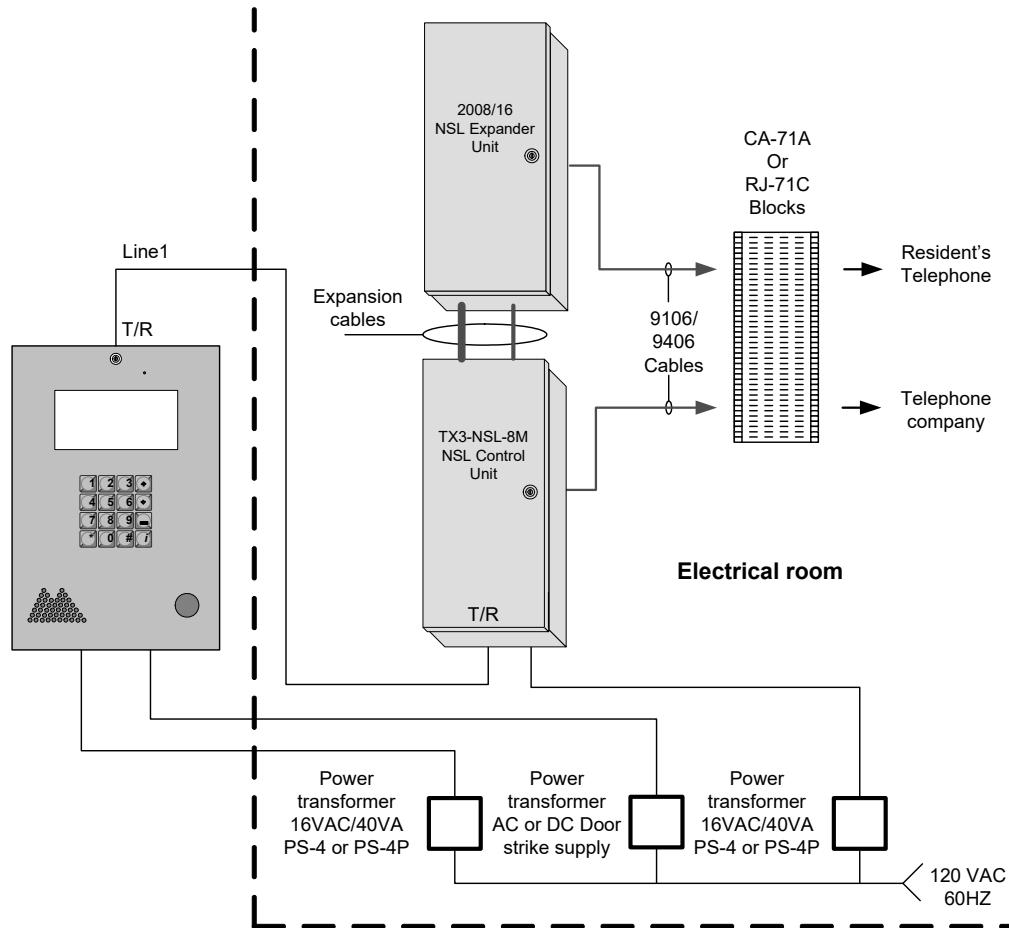
**Note:** There can only be **one** Main Node on an RS-485 subnetwork. That is, you cannot connect one RS-485 subnetwork to another RS-485 subnetwork.

---

### 3.7 Lobby Control Unit Wiring

All units use the PS-4P transformer for the power supply. All wiring is a maximum length of 1000 ft. The door strike power supply depends on the door strike power requirements.

Figure 27 shows a typical wiring arrangement for the Lobby Control Unit.



**Figure 27. Lobby Control Unit Wiring**

**Note:** Install all transformers outside the Lobby Control Unit enclosure.

# 4 Lobby Control Unit Setup

This chapter describes the Lobby Control Unit controller board components and provides information about its operation and setup

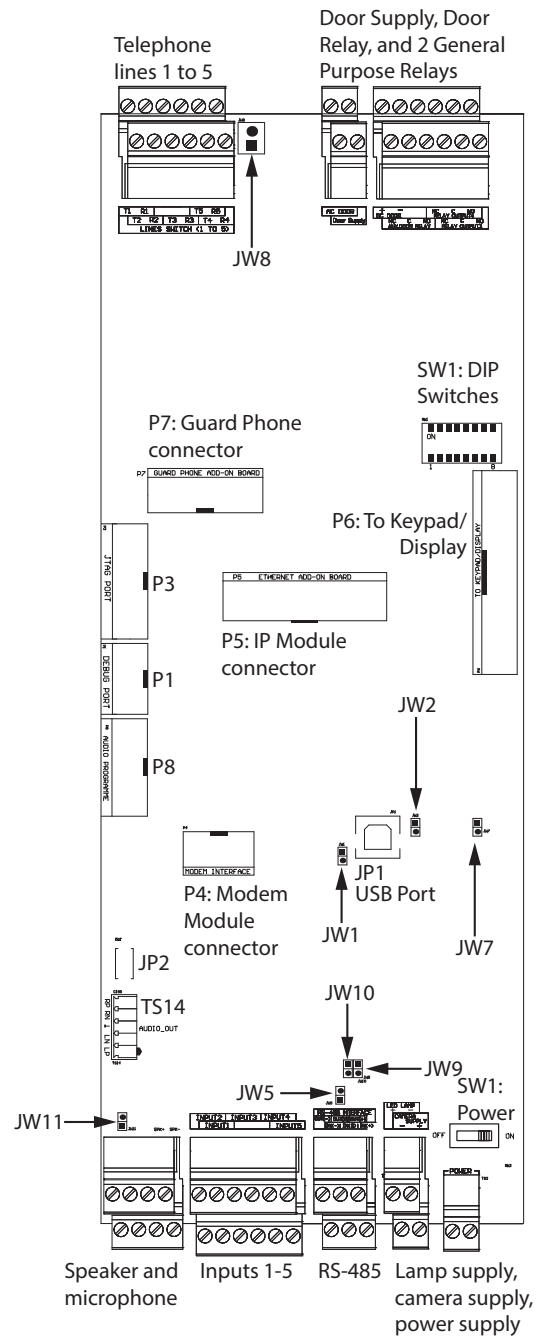
## **This chapter explains**

- Controller Board
- Modem Module
- IP Module
- RS-485 Add-on Module
- Guard Phone Module
- Guard Phone
- Controller ID Setup
- Configuration Using a PC
- Updating Firmware
- Beginning Configuration



## 4.1 Controller Board

Figure 28 shows the general layout of the Lobby Control Unit main controller board. See section 4.2 on page 51 and section 4.3 on page 56 for a detailed description of the connectors at the bottom and top of the controller board.



**Figure 28. Lobby Control Unit Main Controller Board**

### 4.1.1 Connectors

**JP1 (USB).** Computer connection for firmware download and configuration.

**JP2.** Not used on Lobby Control Units.

**TS14.** Factory use only.

**P1.** Factory use only.

**P3.** Factory use only.

**P4.** Modem Module connector.

**P5.** IP Module connector.

**P6.** Key pad and front door LCD display.

**P7.** Guard Phone Board connector.

**P8.** Factory use only.

### 4.1.2 Potentiometer

**PT1 (if present).** Pulse phone potentiometer. This potentiometer is normally factory set and does not require adjustment.

### 4.1.3 Switches

**SW1.** SW1 sets the unit's RS-485 ID (node address) and the IP addressing mode.

**SW2.** SW2 turns the unit's power ON and OFF for servicing, or to re-start the unit.

### 4.1.4 Jumpers

**JW1.** JW1 is used for updating firmware and is normally open.

**JW2.** JW2 is used for updating firmware and is normally open.

**JW3.** JW3 is not used and is left open.

**JW4.** JW4 is not used and is left open.

**JW5.** If end-of-line 120  $\Omega$  resistors for RS-485 are not available, close JW5 on the first and last controller connected by RS-485. By default this jumper is open.

**JW6 (if present).** JW6 is not used and is left open.

**JW7.** JW7 is open for a Touch Screen unit, and closed otherwise.

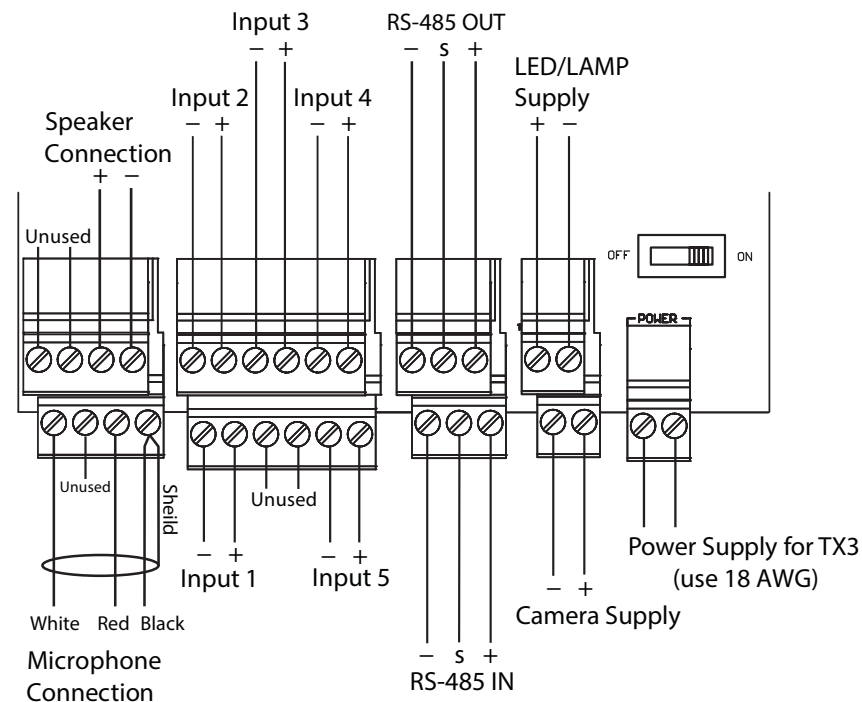
**JW8.** JW8 defines the operating state of the door strike relay as normally open or normally closed. A jumper wire connects to either the normally open (position 2 - top) or normally closed pin (position 1 - bottom). The default setting is normally open (position 2 - top).

**JW9 and JW10.** If there are problems with RS-485 communication, close both JW9 and JW10 on either the first **or** last controller connected by RS-485. By default these jumpers are open.

**JW11:** Leave open. This is the default setting.

## 4.2 Controller Board Connectors - Bottom

Figure 29 shows the connectors at the bottom of the Lobby Control Unit main controller board.



**Figure 29. Controller Board Connectors - Bottom**

### 4.2.1 Microphone Connection

The microphone connection is situated at the bottom left of the main controller board. It connects to the front display and is factory set.

### 4.2.2 Speaker Connection

The speaker connection is situated at the bottom left of the main controller board. It connects to the front display and is factory set.

### 4.2.3 Inputs 1 to 5

Inputs 1 to 5 are situated at the bottom of the main controller board and are assigned specific functions. Inputs 1 to 3 have pre-defined functions and connect to specific devices. Inputs 4 and 5 are general purpose inputs that can be correlated to activate a general purpose output.

Inputs 1 to 5 are designated as follows (see figure 29):

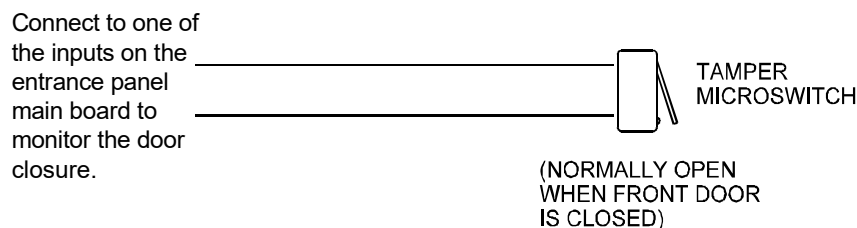
**Input 1. Postal Lock.** Input 1 connects to the Postal Lock. Activation of this input unlocks the main door and starts the main door timer. The door locks when the timer expires or when the door sense input is activated. Daily usage is set as unlimited or limited. When set as limited daily usage is set according to a pre-defined number. Any attempt to use the postal lock beyond a set daily limit causes a warning message to appear and the system to return to normal operation. Input 1 also, when configured, activates a general purpose output to perform any required function.

**Input 2. Fire Panel.** Input 2 connects to the fire alarm panel and receives fire notification. Activation of this input unlocks the main and auxiliary doors. These outputs are active as long as the fire panel input is active. Input 2 also, when configured, activates a general purpose output to perform any required function.

**Input 3. Main Door Sense.** Input 3 connects to the door sense switch. Unlocking the main door activates the main door open timer. Activation of the Main Door Sense locks the main door and resets the main door open timer. This function is typically used to prevent 'tailgating'. Input 3 also, when configured, activates a general purpose output to perform any required function.

**Input 4. General Purpose.** Input 4 is a general purpose input that, when configured, activates a general purpose output to perform any required function. An example of a typical application is the use of an optional tamper switch (see figure 30).

**Input 5. General Purpose.** Input 5 is a general purpose input that, when configured, activates a general purpose output to perform any required function.



**Figure 30. Tamper Switch**

#### 4.2.4 RS-485

An RS-485 terminal lets you easily connect multiple telephone, card access and elevator restriction controllers across a network. The RS-485 connection is situated at the bottom middle of the main controller board and consists of two separate terminals, each for an input and output. See figure 31.

Connect the RS-485 input terminal to the RS-485 output terminal of another controller. See figure 31.

If you do not have end-of-line 120  $\Omega$  resistors, close JW5 on the first and last controllers instead. See section 4.1.4 on page 50.

If there are problems with RS-485 communication, close both JW9 and JW10 on either the first or last controller connected by RS-485.

---

**Note:** Use twisted shielded pair.

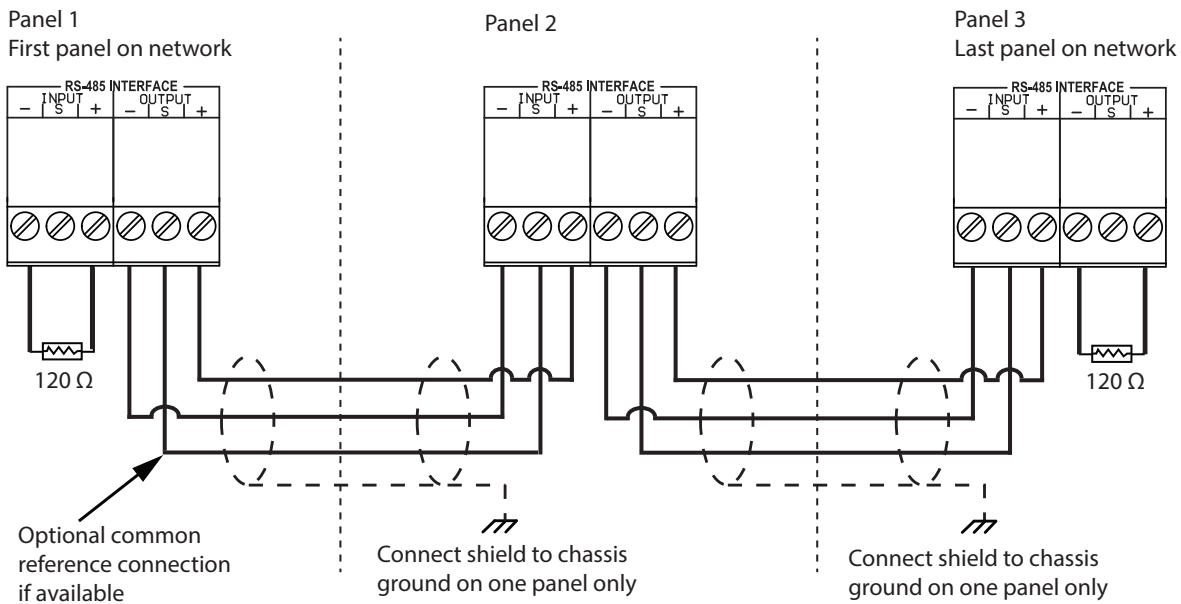
---

Recommended cables:

- RS485 cables
  - Belden 3109A RS-485, (4 pr) 22 AWG (7x30) or equivalent
  - Belden 9842 RS-485, (2 pr) 24 AWG (7x32) or equivalent
  - Belden 9841 RS-485, (1 pr) 24 AWG (7x32) or equivalent
- CAT5 Cables
  - Belden 72001E ETHERNET Cat 5e 2 Pair, 24 AWG or equivalent
  - Belden 70006E Cat 5e, 100Mb/s, Quad, AWG 22 (1) or equivalent

Maximum total length:

- 4000 feet (1244 m) for 22 AWG
- 2500 feet (762.5 m) for 24 AWG



**Figure 31. RS-485 Wiring**

#### 4.2.5 Auxiliary Camera Supply

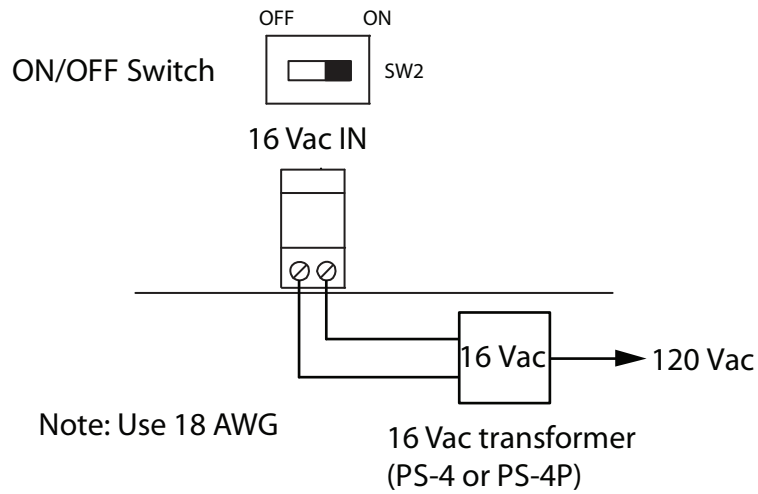
The camera supply connection is situated at the bottom right of the main controller board and provides + 12 Vdc, 600 mA. The camera is controlled by one of the general outputs. The camera's positive terminal connects to the normally open (NO) general output relay contact. The common (C) contact of the general output relay connects to the + 12 Vdc supply terminal. The camera is typically configured to operate when the main door is open.

#### 4.2.6 LED/Lamp Supply

The LED/Lamp connection is situated at the bottom right of the main controller board. This lamp is used with the paper directory models to illuminate the paper directory.

### 4.2.7 Power Supply

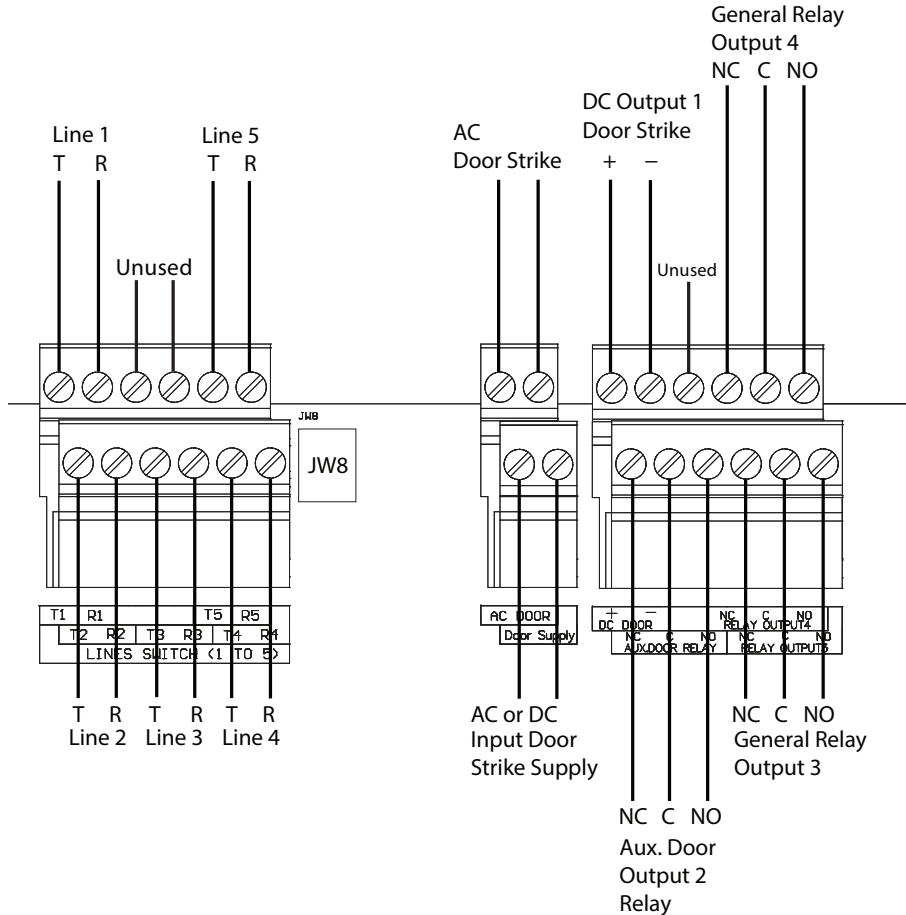
The power supply connection is situated at the bottom right of the main controller board and receives 16 Vac, 40 VA. An external PS-4 or PS-4P plug-in transformer connects to the power terminals. Refer to figure 29 and figure 32.



**Figure 32. Power Supply**

## 4.3 Controller Board Connectors - Top

Figure 33 shows the connectors at the top of the controller board.



**Figure 33. Controller Board Connectors - Top**

### 4.3.1 Telephone Lines 1 to 5

The telephone lines are situated at the top left of the main controller board.

Both NSL and ADC lines can be connected. Each T/R line is polarity insensitive and can be reversed.

---

**Note:** Non-configurable PBX systems are not supported. For more information, contact technical support at Mircom.

---



### 4.3.2 JW8

JW8 must be set to define the operating state of the door strike relay as normally open or normally closed. Use the jumper wire to connect to either the normally open (position 2 - top) or the normally closed pin (position 1 - bottom). For example, when using a maglock, connect the jumper wire to the normally closed pin (position 1). The default setting is normally open (position 2 - top).

### 4.3.3 AC or DC Input Door Strike Supply

The power for the door strike is customer supplied and provides AC or DC power for one of the door strike outputs.

---

**Note:** The controller is able to convert an AC supply to a DC output. The reverse is not true. Consequently, an AC door strike will not work with a DC power supply.

---

The maximum supply for the AC or DC Input Door Strike must not exceed:

- 28 VAC / 1 A max
- 30 VDC / 1 A max

### 4.3.4 AC Output Door Strike

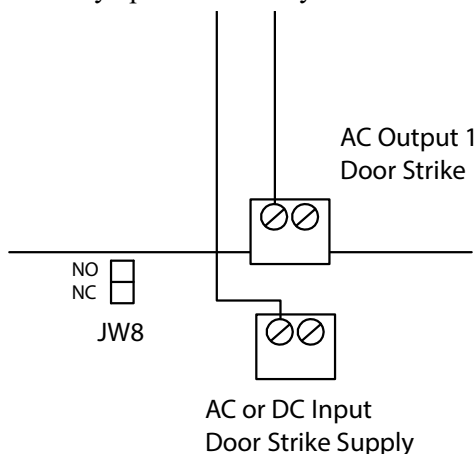
The AC Output Door Strike receives power from the AC Input Door Strike supply. The AC power output remains the same as the power supplied to the AC Input Door Strike.

The AC Output Door Strike is configured for activation by the resident's telephone keypad.

### 4.3.5 DC Output Door Strike

The DC Output Door Strike receives power from the AC or DC Input Door Strike supply and is configured for activation by the resident's telephone keypad. When using a DC input supply, the DC power output remains the same as the input.

When using a dry contact for the main door instead of a door strike or maglock, wire the external controller to the left hand terminals of the AC Door Supply and Input Door Supply as shown in figure 34. JW8 controls whether the contact is normally open or normally closed.



**Figure 34. Main Door Dry Contact Wiring**

#### 4.3.6 Auxiliary Door Relay (Output 2)

The auxiliary door output is configured for activation by the resident's telephone keypad and can be configured to activate general outputs. This relay is a relay contact programmable output with these ratings:

- normally open (NO)
- normally closed (NC) available
- 125 VAC / 2 A
- 30 VDC / 1 A

#### 4.3.7 General Output Relays 3 and 4

Outputs 3 and 4 are relay contact programmable outputs with the following characteristics.

- normally open (NO)
- normally closed (NC) available
- 125 VAC / 2 A
- 30 VDC / 1 A

The general output relays can be correlated to operate for the following events:

- when inputs 1 to 5 are active
- call is started

- call is finished
- call is connected
- access is granted
- access is denied
- system is normal

## 4.4 Modem Module

---

**Note:** The Modem Module is designed to work only with POTS (plain old telephone system) lines.

---



---

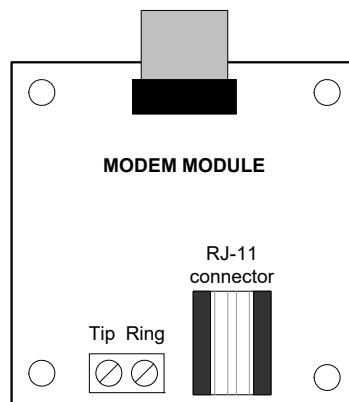
**Attention:** If you use the Modem Module to connect to and configure a Touch Screen, then you cannot configure the Touch Screen locally.

---

The Modem Module is located above the TX3 Lobby Control Unit controller board on the bottom left hand side. See figure 28.

The module has two telephone connectors; an RJ-11 connector and a terminal block as shown in figure 35. The terminal block T/R line is polarity insensitive and can be reversed.

The ribbon cable connects to the P4 connector on the controller board.



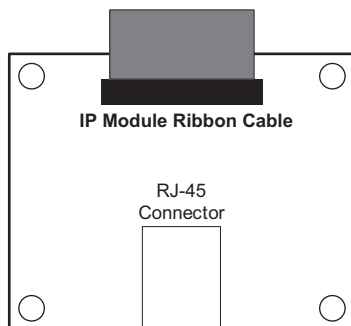
**Figure 35. Modem Module Telephone Connectors**

For a description on how to install the modem board see the Modem Manual Installation Instructions LT-971.

## 4.5 IP Module

The IP Module connects the Lobby Control Unit to an Ethernet TCP/IP network. The IP Module ribbon cable connects to the P5 connector on the controller board (see figure 28). This allows you to configure and monitor the TX3 devices on your system using a computer and an Ethernet connection.

The IP Module has an RJ-45 connector that connects to the Ethernet network using a standard Ethernet cable as shown in figure 36.



**Figure 36. IP Module Data and Ethernet Connectors**

For a description on how to install the IP Module, see LT-1161 TX3-IP IP Module Installation Instructions.

---

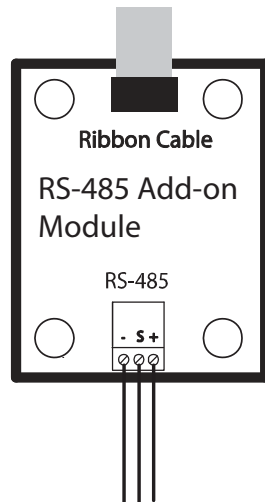
**Note:** The TX3-IP IP Module can only be installed on models that end with “-A” or “-B” or “-C” (for example, TX3-ER-8-A).

---

## 4.6 RS-485 Add-on Module

The RS-485 Add-on Module converts RS-485 signals to USB and is part of the USB to RS-485 Adapter (TX3-USB-AD). The RS-485 Add-on Module ribbon cable connects to the P4 connector on the controller board. See figure 28.

The module has an RS-485 connector as shown in figure 37.



**Figure 37. RS-485 Add-on Module**

For a description on how to install the RS-485 Add-on Module see the USB to RS-485 Adapter Installation Instructions LT-6027.

**Table 1: RS-485 Add-on Jumper Settings**

Mode	JW1	JW2
No termination	Open	Open
AC termination 120R + 1nF	Short	Open
No termination	Open	Short
DC termination 120R (Factory Default)	Short	Short

---

**Note:** For the main application of the RS-485 Add-on Module, JW1 and JW2 should both be shorted.

---

## 4.7 Wiegand Output Module

The TX3-WIEGAND-OUT Wiegand Output Module connects to the Lobby controller board. A Telephone Access panel or Touch Screen with the Wiegand Output Module installed can send a facility code and a card code to a third-party access control system. The output sent is shown in Table 2.

**Table 2: TX3-WIEGAND-OUT Output**

Event	Facility Code	Card Code
Access is granted by the resident after a visitor calls	167	Dial code associated with the resident
Access is denied by the resident after a visitor calls	168	Dial code associated with the resident
Access is granted by a keyless code	169	Dial code associated with the resident whose keyless code is used

The module has Wiegand connector and a ribbon cable. The ribbon cable connects to the P4 connector on the Lobby controller board.

For a description on how to install the module, see the TX3-WIEGAND-OUT Installation Instructions LT-6682.

## 4.8 Guard Phone Module

The TX3-GPM Guard Phone Module mounts above the TX3 Lobby Control Unit main board on the top left hand side. See figure 28.

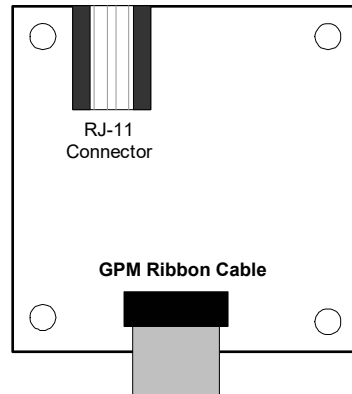
---

**Note:** The Guard Phone Module works only on NSL systems.

---

The module has two connectors, an RJ-11 connector and a ribbon cable as shown in figure 38.

The TX3-GPM ribbon cable connects to the P7 connector on the TX3 Lobby Control Unit main board. The guard phone uses a telephone cable to connect to the RJ-11 connector.



**Figure 38. Guard Phone Module**

For a description on how to install the modem board see the Guard Phone Manual Installation Instructions LT-972.

## 4.9 Guard Phone

The Guard phone is an auxiliary phone that plugs into the RJ-11 connector on the Guard Phone Module on the Lobby Control Unit. This phone provides most of the same features as a normal telephone and lets you do the following:

- Place calls to the Lobby Control Unit.
- Receive calls from the Lobby Control Unit.
- Place calls to residents.

### To call the Lobby Control Unit phone

1. Pick up the guard phone, wait for the dial tone and dial \*9997. The guard phone connects to the Lobby Control Unit.
2. Press the # key on the guard phone. The main door unlocks.

### To receive a call from the Lobby Control Unit

1. When a visitor dials 9997 on the Lobby Control Unit the guard phone rings. Pick up the phone. The Lobby Control Unit is now connected to the guard phone.
2. Press the # key on the guard phone. The main door unlocks.

### To call a resident from the guard phone

1. Pick up the guard phone and wait for the dial tone.
2. Dial \*DDDD (where DDDD is the resident's four digit dial code). The resident phone rings. When the resident picks up the phone, the connection is established.
3. Press the # key on the guard phone. The main door unlocks.

## 4.10 Controller ID Setup

Use the SW1 DIP switches on the Lobby Control Unit main controller board to set the unit's ID address on the RS-485 network. The individual switches are numbered 1 to 8 from left to right, and are marked as either ON or OFF. The first six switches (1, 2, 3, 4, 5 and 6) set the address ID.

Every TX3 System Lobby Control Unit requires a unique unit ID. The unit ID settings do not need to be in sequence but it is recommended to assign IDs starting from 1, using increments of one (for example, 1, 2, 3, 4, and so on). Unit IDs must not be duplicated.

---

**Note:** One of the networked units with a real time clock, such as Touch Screen, Lobby Control or Card Access must have their network address set to 1.

---

DIP switch SW1 is found at the top central portion of the controller board, see figure 28.

Table 3 shows the SW1 DIP switch settings for each Lobby Control Unit.

---

**Note:** DIP switch 7 must be ON for Touch Screen units and OFF for non-Touch Screen units.

---

---

**Note:** For units with an IP Module installed, DIP Switch 8 determines how the IP address is assigned to the IP Module.

- **DIP Switch 8 OFF:** The IP address is assigned using a DHCP server. This is the default factory setting.
- **DIP switch 8 ON:** The IP address is assigned using the TX3 Configurator software.

---



**Table 3: Lobby Control Unit SW1 DIP Switch Settings**

Lobby Control Unit ID #	Switch 1	Switch 2	Switch 3	Switch 4	Switch 5	Switch 6
0 (not allowed as a Lobby Control Unit ID 0 is used for PC ID)	OFF	OFF	OFF	OFF	OFF	OFF
1	ON	OFF	OFF	OFF	OFF	OFF
2	OFF	ON	OFF	OFF	OFF	OFF
3	ON	ON	OFF	OFF	OFF	OFF
4	OFF	OFF	ON	OFF	OFF	OFF
5	ON	OFF	ON	OFF	OFF	OFF
6	OFF	ON	ON	OFF	OFF	OFF
7	ON	ON	ON	OFF	OFF	OFF
8	OFF	OFF	OFF	ON	OFF	OFF
9	ON	OFF	OFF	ON	OFF	OFF
10	OFF	ON	OFF	ON	OFF	OFF
11	ON	ON	OFF	ON	OFF	OFF
12	OFF	OFF	ON	ON	OFF	OFF
13	ON	OFF	ON	ON	OFF	OFF
14	OFF	ON	ON	ON	OFF	OFF
15	ON	ON	ON	ON	OFF	OFF
16	OFF	OFF	OFF	OFF	ON	OFF
17	ON	OFF	OFF	OFF	ON	OFF
18	OFF	ON	OFF	OFF	ON	OFF
19	ON	ON	OFF	OFF	ON	OFF
20	OFF	OFF	ON	OFF	ON	OFF
21	ON	OFF	ON	OFF	ON	OFF
22	OFF	ON	ON	OFF	ON	OFF
23	ON	ON	ON	OFF	ON	OFF
24	OFF	OFF	OFF	ON	ON	OFF
25	ON	OFF	OFF	ON	ON	OFF
26	OFF	ON	OFF	ON	ON	OFF
27	ON	ON	OFF	ON	ON	OFF
28	OFF	OFF	ON	ON	ON	OFF
29	ON	OFF	ON	ON	ON	OFF
30	OFF	ON	ON	ON	ON	OFF
31	ON	ON	ON	ON	ON	OFF
32	OFF	OFF	OFF	OFF	OFF	ON
33	ON	OFF	OFF	OFF	OFF	ON
34	OFF	ON	OFF	OFF	OFF	ON
35	ON	ON	OFF	OFF	OFF	ON
36	OFF	OFF	ON	OFF	OFF	ON
37	ON	OFF	ON	OFF	OFF	ON

**Table 3: Lobby Control Unit SW1 DIP Switch Settings (Continued)**

Lobby Control Unit ID #	Switch 1	Switch 2	Switch 3	Switch 4	Switch 5	Switch 6
38	OFF	ON	ON	OFF	OFF	ON
39	ON	ON	ON	OFF	OFF	ON
40	OFF	OFF	OFF	ON	OFF	ON
41	ON	OFF	OFF	ON	OFF	ON
42	OFF	ON	OFF	ON	OFF	ON
43	ON	ON	OFF	ON	OFF	ON
44	OFF	OFF	ON	ON	OFF	ON
45	ON	OFF	ON	ON	OFF	ON
46	OFF	ON	ON	ON	OFF	ON
47	ON	ON	ON	ON	OFF	ON
48	OFF	OFF	OFF	OFF	ON	ON
49	ON	OFF	OFF	OFF	ON	ON
50	OFF	ON	OFF	OFF	ON	ON
51	ON	ON	OFF	OFF	ON	ON
52	OFF	OFF	ON	OFF	ON	ON
53	ON	OFF	ON	OFF	ON	ON
54	OFF	ON	ON	OFF	ON	ON
55	ON	ON	ON	OFF	ON	ON
56	OFF	OFF	OFF	ON	ON	ON
57	ON	OFF	OFF	ON	ON	ON
58	OFF	ON	OFF	ON	ON	ON
59	ON	ON	OFF	ON	ON	ON
60	OFF	OFF	ON	ON	ON	ON
61	ON	OFF	ON	ON	ON	ON
62	OFF	ON	ON	ON	ON	ON
63	ON	ON	ON	ON	ON	ON

## 4.11 Configuration Using a PC

In order to correctly utilize the capabilities of the TX3 Telephone Access System you must first plan and establish how you want to configure the system for your application.

The easiest way to configure the Lobby Control Unit is with the Mircom TX3 Configuration Software. This software is provided on a single CD-ROM or USB flash drive.

The PC connects to the Lobby Control unit controller board using one of the following methods:

- USB cable from the PC to the TX3 Main Lobby board
- Ethernet connection (Lobby Control Unit must have an IP Module)

- Modem connection (Lobby Control Unit must have a Modem Module)

See section 7 on page 96 for the list of compatible modems.

Additional modems are currently being tested for compatibility.

The TX3 configuration is set using either the unit's own keypad and display or via the PC Configuration Software.

#### 4.11.1 PC System Requirements

See LT-995 Touch Screen Administrators Guide for information on installing the TX3 Configurator software.

## 4.12 Updating Firmware

You can update the firmware on your panel with the TX3 Configurator software by using one of the following methods.

- Firmware Upgrade Wizard
- Network Firmware Upgrade

The Firmware Upgrade Wizard can be used to update only one panel at a time. It will work on any panel. This method does not work on 64-bit versions of Windows.

The Network Firmware Upgrade procedure can update more than one panel at the same time. In order to use the Network Firmware Upgrade, all of the panels must already have firmware that supports this feature installed on them.

Refer to LT-995, TX3 Configuration and Administrator Manual, for instructions on how to perform both of these firmware upgrade methods. LT-995 can be found on the TX3 Configurator Software installation CD, USB flash drive, or on the Mircom website.

#### 4.12.1 Firmware Version Control

The firmware version number is accessible from the Configurator software and changes whenever there is a major, minor or revision update.

---

**Note:** When the major or minor version of the firmware is updated, the configuration is reset to the default values.

---

The following convention is used whenever there is a major, minor or revision change:

**Initial release.** Version 1.00.0

**Major change.** Version 2.00.0

**Minor change.** Version 2.01.0

**Revision changes.** Version 2.01.1

## 4.13 Beginning Configuration

The Lobby Control Unit controller is now ready for configuration using the USB. An optional method is to use the RS-485 or modem connection.

For a complete description of the configuration and on how to establish a connection to the Lobby Control Unit using USB, Ethernet, RS-485, or modem, see the following documentation:

- LT-995 Configuration and Administration Guide
- LT-973 TX3 Configurator Quick Start

Verify the following:

- Ensure that the controller and all connected devices and components are fully operational.
- Ensure the controller DIP Switches (SW1) are set with a unique network address.
- Ensure the Configurator software is set with the correct controller network address.
- Ensure that your PC and the Configurator are set with the correct date and time.

### To start the configuration

1. Connect the PC to the controller using the USB port.
2. Launch the Configurator and click **Connect**. Once connected the connection icon appears in the Configurator tool bar.
3. Configure the Telephone Access system using the instructions in the Configurator Software Program TX3-MSW or the LT-995 Configuration and Administration Guide.

# 5 NSL Relay Cabinet Installation and Wiring

This chapter provides information about the NSL Relay Cabinet Installation and Wiring.

## **This chapter explains**

- NSL Relay Cabinet Mechanical Installation
- NSL Relay Control Unit and Expanders
- Wiring the TX3-NSL-8M Main Controller Board
- Updating Firmware

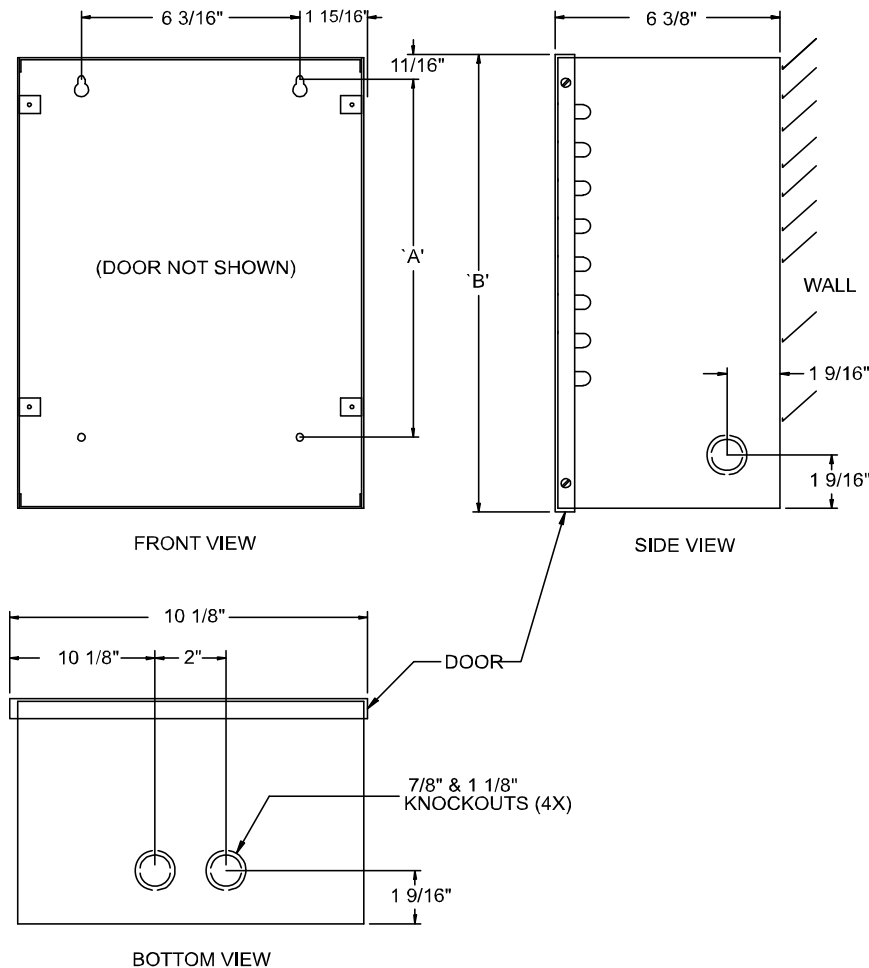
## 5.1 NSL Relay Cabinet Mechanical Installation

The NSL Relay cabinets contain the telephone switching equipment and are typically mounted in the electrical/telephone room of a building.

NSL Relay cabinets are factory assembled in one of the following enclosure sizes:

- TX3-NSL-8M NSL Unit: 27 inch high enclosure
- TX3-8EC NSL Expander: 13 15/16 inch high enclosure
- TX3-16EC NSL Expander: 27 inch high enclosure

The TX3-8EC NSL Expander includes the 13 15/16 inch enclosure. The TX3-NSL-8M Relay Cabinet includes the 27 inch enclosure. The TX3-16EC NSL Expander includes the 27 inch enclosure. See figure 39 and Table 4.



**Figure 39. NSL Relay Cabinet**

The top two mounting holes are 6 3/16 inches apart.

**Table 4: NSL Relay Cabinet Dimensions**

<b>Model Number</b>	<b>Dim 'A'</b>	<b>Dim 'B'</b>
TX3-8EC	10 1/8"	13 15/16"
TX3-NSL-8M	23 3/16"	27"
TX3-16EC	23 3/16"	27"

### **To mount the NSL Relay Cabinet**

1. Using the back cover as a template mark the top two mounting hole locations 6 3/16 inches apart as shown in figure 39.
2. Place the screws halfway into the wall in the position shown using a suitable screw.
3. Hang the box onto the two screws.
4. Screw the other two screws at the bottom of the panel.
5. Tighten all four screws into place.

## 5.2 NSL Relay Control Unit and Expanders

The TX3-NSL-8M NSL Relay Control Unit, TX3-8EC and TX3-16EC NSL Relay Backplane Expanders perform the following functions:

- Telephone switching functionality to facilitate voice communication between the resident's phone and the lobby
- Generating call waiting tones to the resident if the line is busy.
- Provide access control by the resident using the telephone keypad.
- Low power operation from one 16V AC transformer.

### 5.2.1 TX3-NSL-8M NSL Control Unit

The TX3-NSL-8M Relay Control Unit consists of:

- NSL Main Controller Board
- NSL Backplane Board

Figure 40 shows a TX3-NSL-8M Relay Control Unit.

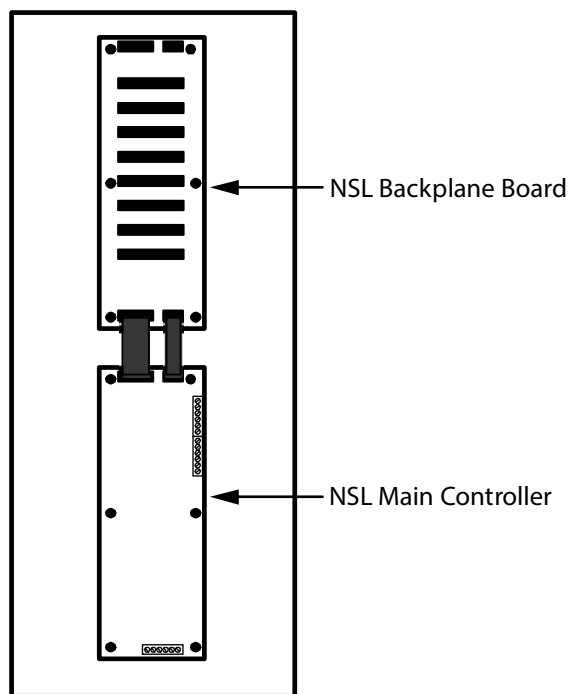


Figure 40. TX3-NSL-8M Relay Control Unit



### **5.2.2 2012 NSL Relay**

The NSL Backplane board contains up to eight 2012 NSL Relay Boards. Each 2012 NSL Relay Board has 12 relays, allowing for a total of 96 relays.

### **5.2.3 NSL Expanders**

NSL expanders plug into the NSL Backplane Board connectors and consist of:

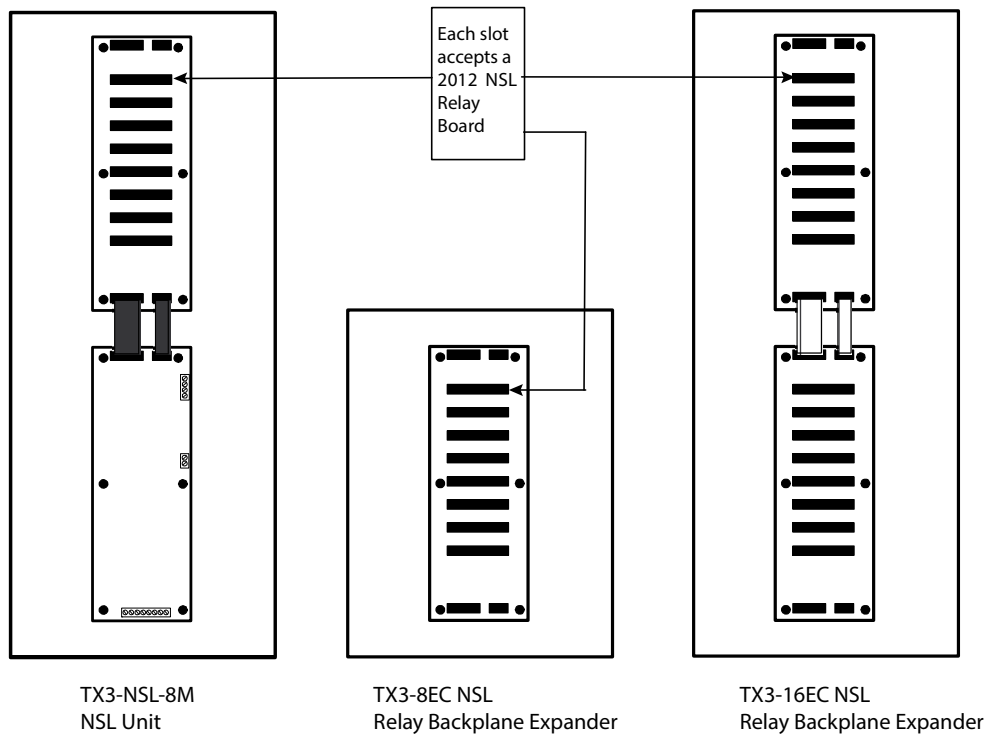
- TX3-8EC NSL Eight Relay Card Backplane Expander
- TX3-16EC NSL 16 Relay Card Backplane Expander

Extension cables provide connections between adjacent enclosures using the expansion connectors. See section 5.3 on page 75 for a description of the NSL Backplane Board connectors.

The TX3-8EC NSL Eight Relay Backplane Expander and the TX3-16EC NSL 16 Relay Backplane Expander are housed in their own cabinet and can be connected with two cables to provide an additional capacity for 8 or 16 relay boards respectively.

The expanders allow a total of 16 backplanes to be installed, allowing for up to 1535 relays.

**Note:** The TX3-NSL-8M and any TX3-8EC and/or TX3-16EC must all be adjacent to each other, mounted on the same wall and in the same room.



**Figure 41. NSL Expanders**

## 5.3 Wiring the TX3-NSL-8M Main Controller Board

The TX3-NSL-8M NSL Main Controller Board has both ribbon cable sockets and screw terminals.

---

**Attention:** High voltages are present on this board during the ringing of suite telephones.

---

Figure 42 shows the general layout of the TX3-NSL-8M Main Controller board components.

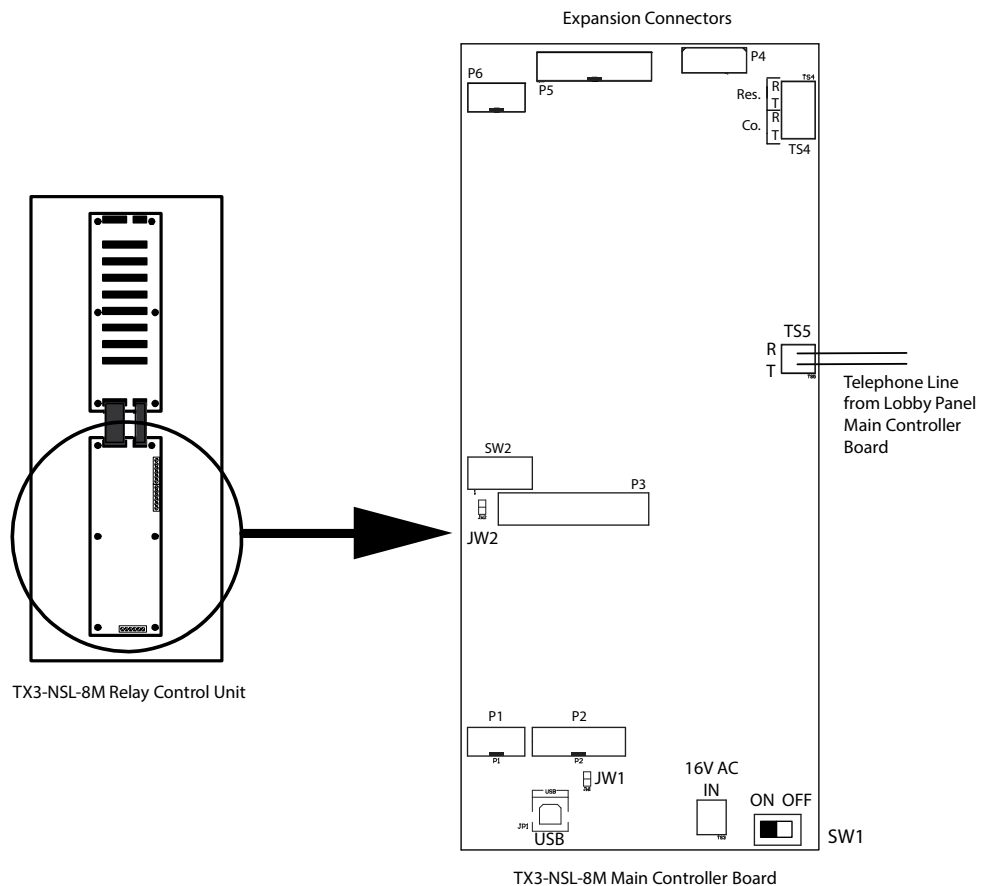


Figure 42. TX3-NSL-8M Main Controller Board

### 5.3.1 Connectors

**USB.** Computer connection for firmware download.

**P1 and P2.** Not used.

**P3.** Not used.

**P4.** Expansion to the NSL Controller back-plane.

**P5.** Expansion to the NSL Controller back-plane.

**P6.** Not used.

**TS4.** Not used. If there is a resistor connected to this terminal, do not remove it.

**TS5.** Telephone line from Lobby panel main controller board.

### **5.3.2 Switches**

**SW1.** Turns the unit's power ON and OFF for servicing, or to re-start the unit.

**SW2.** Not used.

### **5.3.3 Jumpers**

**JW1.** JW1 is used for updating firmware and is normally open.

**JW2.** JW2 is used for updating firmware and is normally open.

### **5.3.4 Telephone Line**

Each NSL control unit provides a single telephone line connection to the Lobby Control Unit. See figure 43 and figure 44.

Each Lobby Control Unit panel can use any one of the five telephone lines on the Lobby Control Unit Main Controller Board to communicate to an ADC telephone system or to an NSL relay control unit.

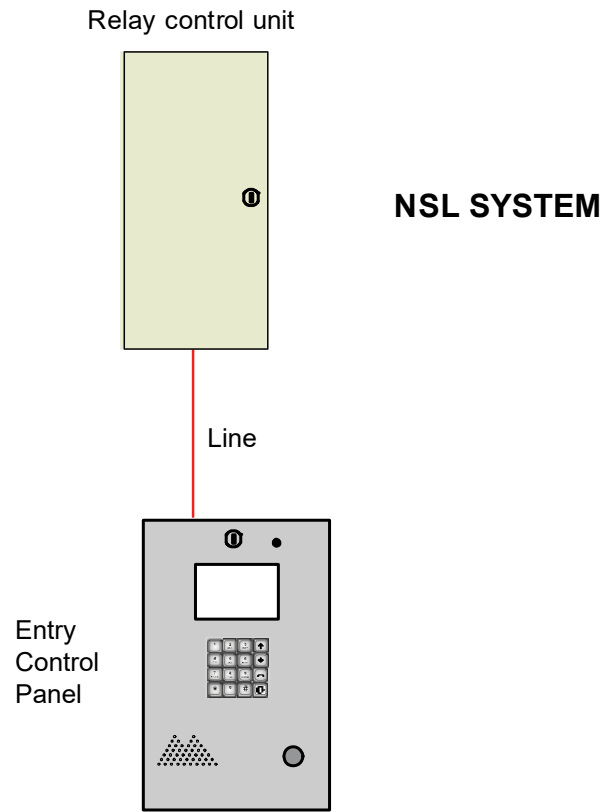
There are many possibilities for connecting Entry Control panels and NSL control units, but each main Lobby Control Unit requires one individual telephone line to each NSL control unit.

Lobby Control Units connect to the NSL and control units through telephone lines. Telephone lines are not connected to expansion units.

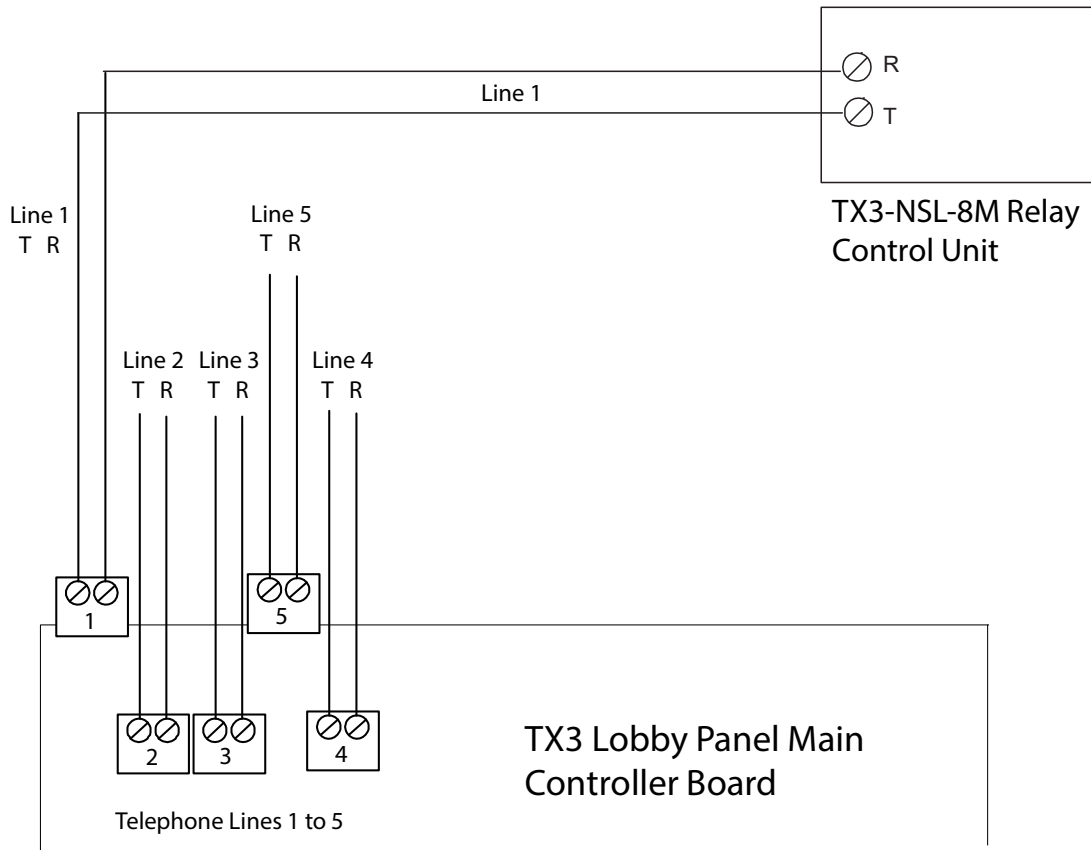
Expansion relay control units do not require an individual telephone line.

### **5.3.5 Ring Signal**

The NSL control unit provides a 45 Vrms ring signal on REN5 with a line length of 503 m (1650 feet). The minimal ring signal level for North America is 40 Vrms.



**Figure 43. NSL System with Telephone Line**



**Figure 44. NSL Controller Telephone Lines**

#### To test the TX3-8M-NSL Relay Control unit

1. Connect a telephone to the TX3-8M-NSL Relay Control unit telephone terminal block (see figure 42).
2. Pick up the telephone. A dial tone is heard.
3. Dial \*RRRR#, where RRRR is the relay code. A resident line LED relay card light turns on.
4. Hang up. The resident line LED relay card light turns off. The TX3-8M-NSL Relay Control unit is operational.
5. Perform the same test for all of the relay codes.

---

**Note:** Resident telephones associated with the relay card will ring. If the resident picks up their telephone a connection will be established.

---

6. Disconnect the telephone and proceed with the installation.

### 5.3.6 Connecting to an NSL line

Use the following calling pattern when connecting to the NSL Panel.

\*RRRRPPNNC#

---

**Note:** PP and NN and C are optional

---

**where:**

RRRR is the relay code.

PP is the ring pattern.

NN is the maximum number of rings.

C is call transfer key.

#### To connect to an NSL line

1. Dial \*RRRRPPNNC#.

### 5.3.7 TX3-NSL-8M/TX3-8EC/TX3-16EC NSL Unit Relay Backplane Boards

The TX3-NSL-8M / TX3-8EC / TX3-16EC NSL Unit Relay Backplane Boards have both ribbon cable sockets and relay board sockets.

Figure 45 shows the general layout of the TX3-NSL-8M NSL Unit controller board components.

### 5.3.8 Connectors

Up to 16 NSL backplanes connect to an NSL main controller board. Each has a set of 16 positions for a jumper plug. The first backplane is jumpered for "1", the next for "2", and so on up to "16".

**P1.** Expansion from the previous controller or the NSL main controller board.

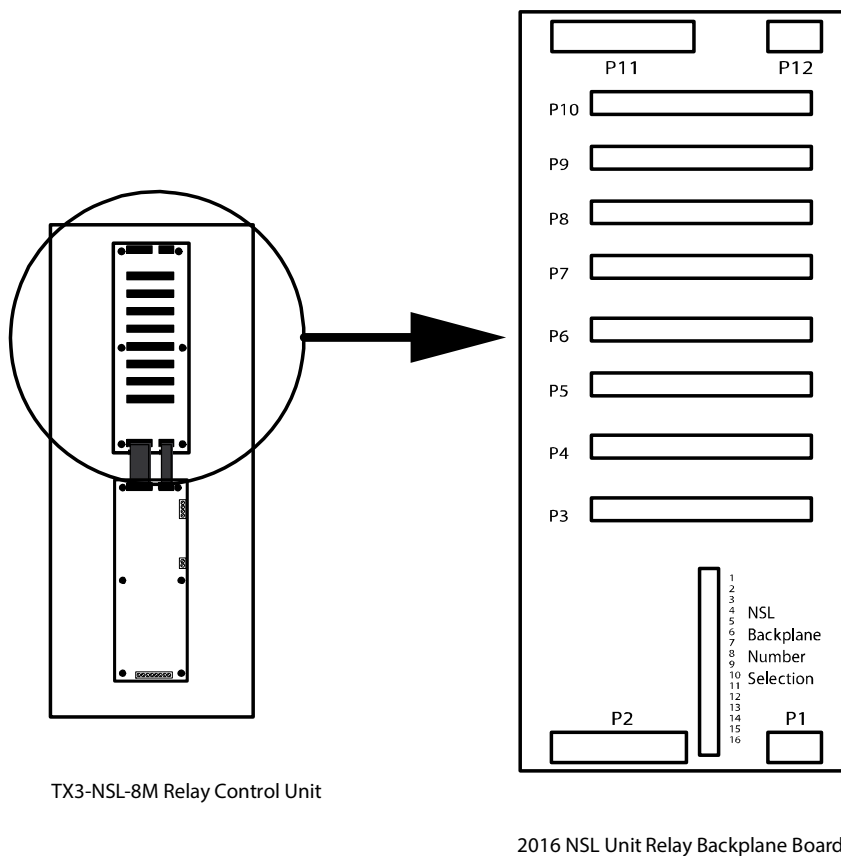
**P2.** Expansion from the previous controller or the NSL main controller board.

**P3 to P10.** Connectors for the 2012 NSL Relay Boards. (eight relay boards per backplane.)

**P11.** Expansion to the next backplane.

**P12.** Expansion to the next backplane.

NSL Backplane Number Selector. (located between P1 and P2).



**Figure 45. NSL Backplane**

---

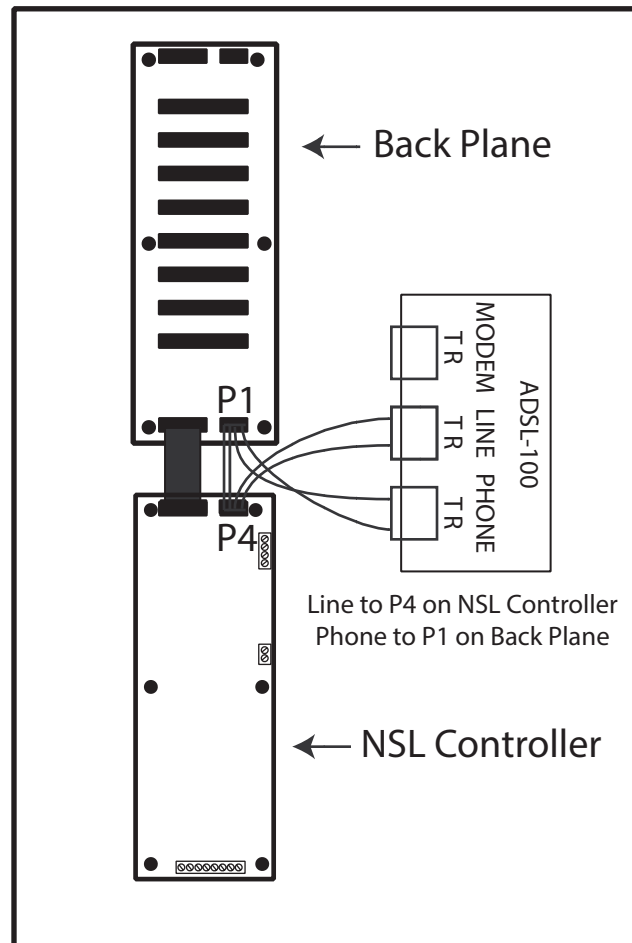
**Attention:** High voltages are present on this board during the ringing of suite telephones.

---

### 5.3.9 Using NSL with Phone Lines that Provide DSL Service

If the building's telephone lines provide both DSL (digital subscriber line) and POT (plain old telephone) services then the ADSL-100 filter module is required to filter data signals. This filter module is installed between P4 on the NSL Controller board and P1 on the first Back Plane board that connects to it. Refer to the figure below for details on connecting the ADSL-100 module.





**Figure 46. ADSL-100 Filter Module Installation**

### 5.3.10 Setting the Backplane Number

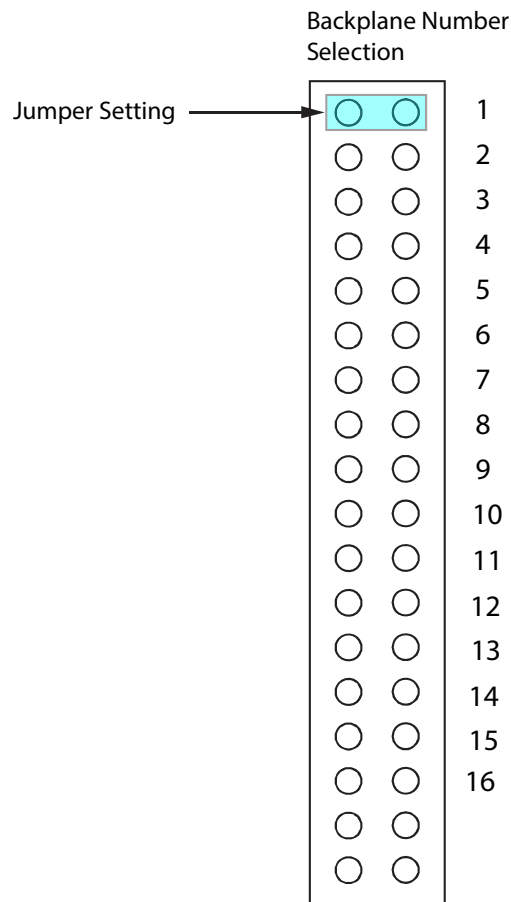
Relay addresses are numbered to show the relay card's connector location and backplane number setting. Table 5 provides sample addresses for the first three backplane number jumper settings.

For example, when the backplane number jumper setting is set to 1, the first relay on P3 relay board has an address of 1. When the backplane number setting is set to 2, the first relay on P3 relay board has an address of 97.

#### To set the backplane number

1. Determine the relay address according to the relay card's connector location and backplane number setting.

- Using a jumper, set the backplane number across the Backplane Number Selection pins as shown in figure 47.



**Figure 47. Backplane Number Section**

**Table 5: Sample Backplane Relay Addresses**

Connector	Backplane Number Setting		
	Jumper 1 Address 1-96	Jumper 2 Address 97-192	Jumper 3 Address 193-288
<b>P3</b>	1 to 12	97 to 108	193 to 204
<b>P4</b>	13 to 24	109 to 120	205 to 216
<b>P5</b>	25 to 36	121 to 132	217 to 228
<b>P6</b>	37 to 48	133 to 144	229 to 240
<b>P7</b>	49 to 60	145 to 156	241 to 252
<b>P8</b>	61 to 72	157 to 168	253 to 264
<b>P9</b>	73 to 84	169 to 180	265 to 276
<b>P10</b>	85 to 96	181 to 192	277 to 288

### 5.3.11 2012 NSL Relay Board Wiring

The 2012 NSL Relay Board plugs into the backplane boards of the NSL units. There may be up to eight relay boards in each backplane board (to a maximum of 128 relay boards for 16 NSL backplane boards).

In each NSL backplane the relay boards are numbered 1 to 8, starting from the bottom of the backplane and going to the top. Each relay board provides 12 resident telephone lines connections, for a maximum of 1536 telephone lines per system.

Connections are made via the CA-71A BIX Block or RJ-71C Punch Down Block Wiring Configuration as follows:

**CA-71A BIX Block.** The CA-71A (for Canada) wiring configurations of BIX and Punch Down Block are shown in figure 49 and table 6.

**RJ-71C Punch Down Block.** The RJ-71C (for U.S.A.) wiring configurations of BIX and Punch Down Block are shown in figure 50 and table 7.

Normally, the required blocks are installed by the telephone company. Each block serves up to 12 telephone lines.

The 50-pin amphenol connector on the BIX block connects to the 2012 relay card using the standard 9106 cable.

### To connect the 2012 NSL Relay Board

1. Contact the telephone company at least three weeks before the actual installation to order the required blocks.
2. Complete the CA-71A or RJ-71C Block Identification Forms (table 6 and table 7) for the telephone installer. The form shows the telephone installer how the telephone lines connect to the BIX/Punch Down Blocks.
3. Install all BIX Blocks as close as possible to the NSL unit to which they connect.
4. Plug the 2012 NSL Relay Board into the NSL unit's backplane board.
5. Connect the 50-pin amphenol connector on the BIX block to the 2012 relay card using the 9106 cable.
6. Connect the CA-71A BIX Block or RJ-71C Punch Down Block Wiring Configuration.
7. See the special notices on page 107 and provide the following information to the telephone company:
  - Telephone numbers of the lines to which the TX3 system will be connected.
  - The Industry Canada registration number for Canada or the FCC registration number for U.S.A.
  - The Ringer Equivalence Number (REN) of the TX3 system.

---

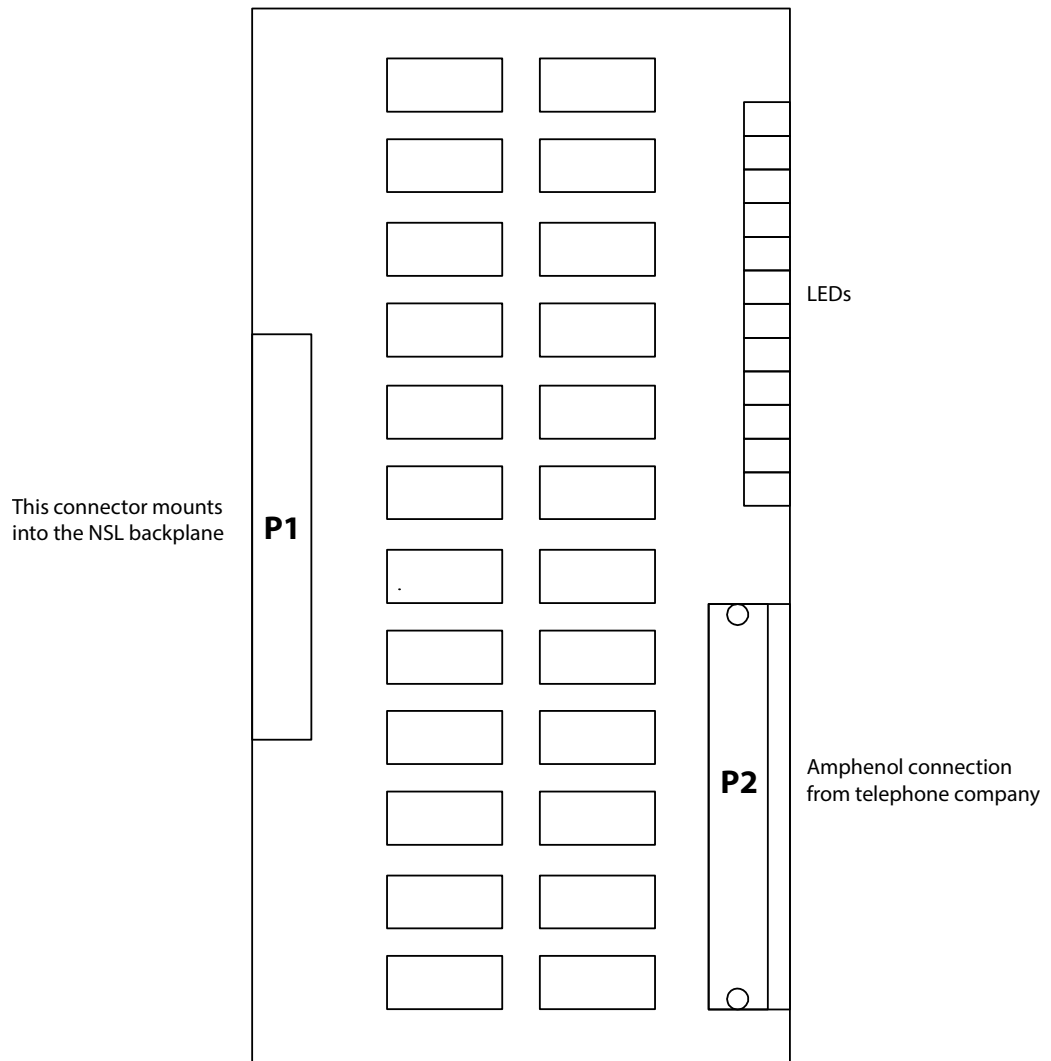
**Note:** RJ-71C wiring configuration is not recognized by all telephone companies. For Bell Canada who has jurisdiction for Ontario and Quebec, refer to CA-71A block for interconnect to the telephone entry systems.

---

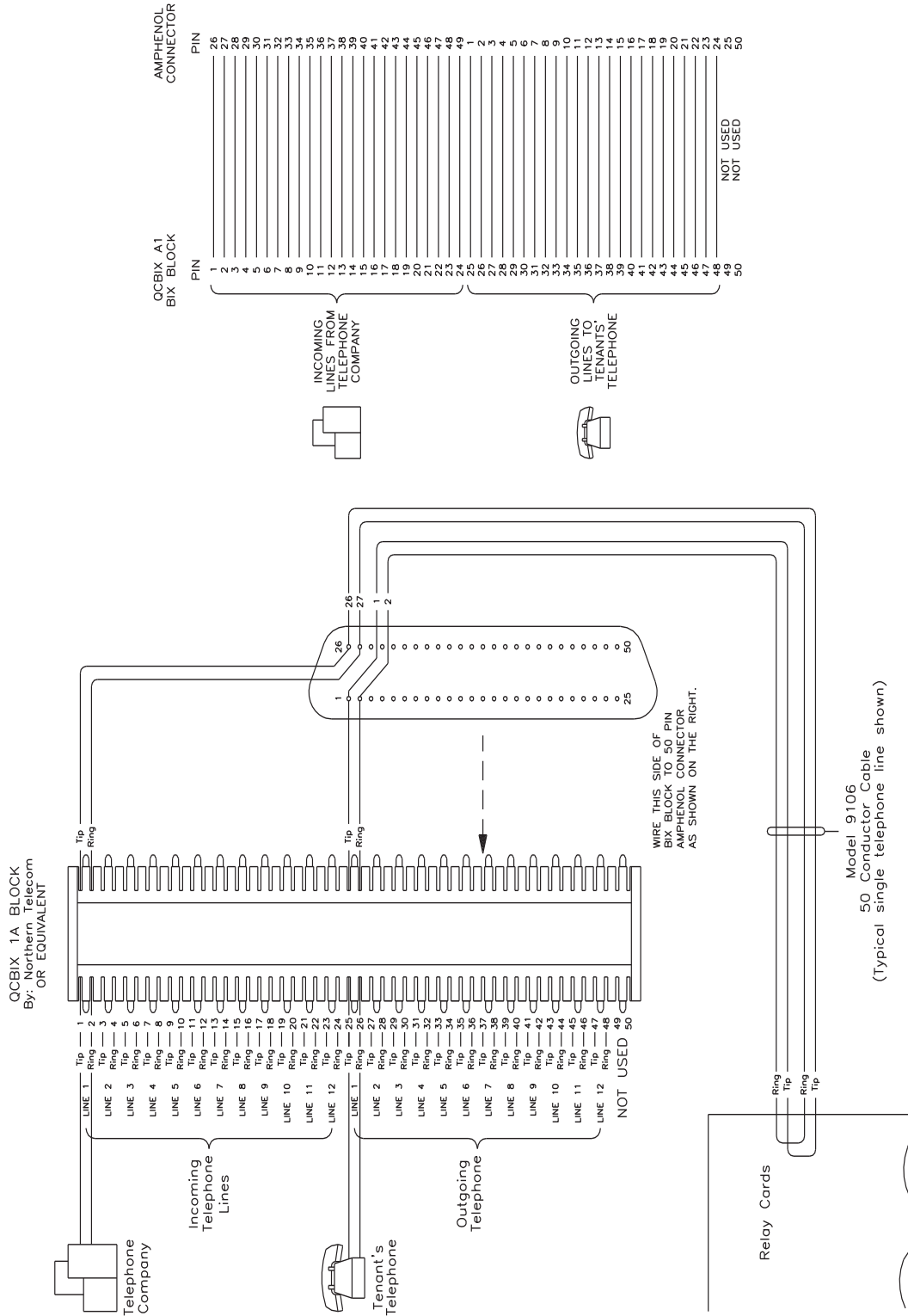
---

**Note:** Since there are two types of block wiring configuration, CA-71A and RJ-71C, Mircom recommends that you contact the telephone company as to what block wiring configuration is available. We suggest using Mircom's standard 9106 cable for CA-71A or RJ-71C configured blocks since they are straightforward and easy to use.

---



**Figure 48. 2012 NSL Relay Board**



**Table 6: CA-71A BIX Block Identification Form**

Relay Cabinet No. \_\_\_\_ of \_\_\_\_ Decoder/Mother Board No. \_\_\_\_

Relay Card/ Amp. Jack #	Telephone Number	Block Pins Tel. Co./Res.	Apt. #	Dial Code	Relay/ Line #	Relay Card/ Amp. Jack #	Telephone Number	Block Pins Tel. Co./Res.	Apt. #	Dial Code	Relay/ Line #
1		1,2/25,26			0001	5		1,2/25,26			0049
		3,4/27,28			0002			3,4/27,28			0050
		5,6/29,30			0003			5,6/29,30			0051
		7,8/31,32			0004			7,8/31,32			0052
		9,10/33,34			0005			9,10/33,34			0053
		11,12/35,36			0006			11,12/35,36			0054
		13,14/37,38			0007			13,14/37,38			0055
		15,16/39,40			0008			15,16/39,40			0056
		17,18/41,42			0009			17,18/41,42			0057
		19,20/43,44			0010			19,20/43,44			0058
		21,22/45,46			0011			21,22/45,46			0059
		23,24/47,48			0012			23,24/47,48			0060
2		1,2/25,26			0013	6		1,2/25,26			0067
		3,4/27,28			0014			3,4/27,28			0062
		5,6/29,30			0015			5,6/29,30			0063
		7,8/31,32			0016			7,8/31,32			0064
		9,10/33,34			0017			9,10/33,34			0065
		11,12/35,36			0018			11,12/35,36			0066
		13,14/37,38			0019			13,14/37,38			0067
		15,16/39,40			0020			15,16/39,40			0068
		17,18/41,42			0021			17,18/41,42			0069
		19,20/43,44			0022			19,20/43,44			0070
		21,22/45,46			0023			21,22/45,46			0071
		23,24/47,48			0024			23,24/47,48			0072

**Table 6: CA-71A BIX Block Identification Form (Continued)**

Relay Cabinet No. \_\_\_\_\_ of \_\_\_\_\_ Decoder/Mother Board No. \_\_\_\_\_

Relay Card/ Amp. Jack #	Telephone Number	Block Pins Tel. Co./Res.	Apt. #	Dial Code	Relay/ Line #	Relay Card/ Amp. Jack #	Telephone Number	Block Pins Tel. Co./Res.	Apt. #	Dial Code	Relay/ Line #
3		1,2/25,26			0025	7		1,2/25,26			0073
		3,4/27,28			0026			3,4/27,28			0074
		5,6/29,30			0027			5,6/29,30			0075
		7,8/31,32			0028			7,8/31,32			0076
		9,10/33,34			0029			9,10/33,34			0077
		11,12/35,36			0030			11,12/35,36			0078
		13,14/37,38			0031			13,14/37,38			0079
		15,16/39,40			0032			15,16/39,40			0080
		17,18/41,42			0033			17,18/41,42			0081
		19,20/43,44			0034			19,20/43,44			0082
		21,22/45,46			0035			21,22/45,46			0083
		23,24/47,48			0036			23,24/47,48			0084
4		1,2/25,26			0037	8		1,2/25,26			0085
		3,4/27,28			0038			3,4/27,28			0086
		5,6/29,30			0039			5,6/29,30			0087
		7,8/31,32			0040			7,8/31,32			0088
		9,10/33,34			0041			9,10/33,34			0089
		11,12/35,36			0042			11,12/35,36			0090
		13,14/37,38			0043			13,14/37,38			0091
		15,16/39,40			0044			15,16/39,40			0092
		17,18/41,42			0045			17,18/41,42			0093
		19,20/43,44			0046			19,20/43,44			0094
		21,22/45,46			0047			21,22/45,46			0095
		23,24/47,48			0048			23,24/47,48			0096



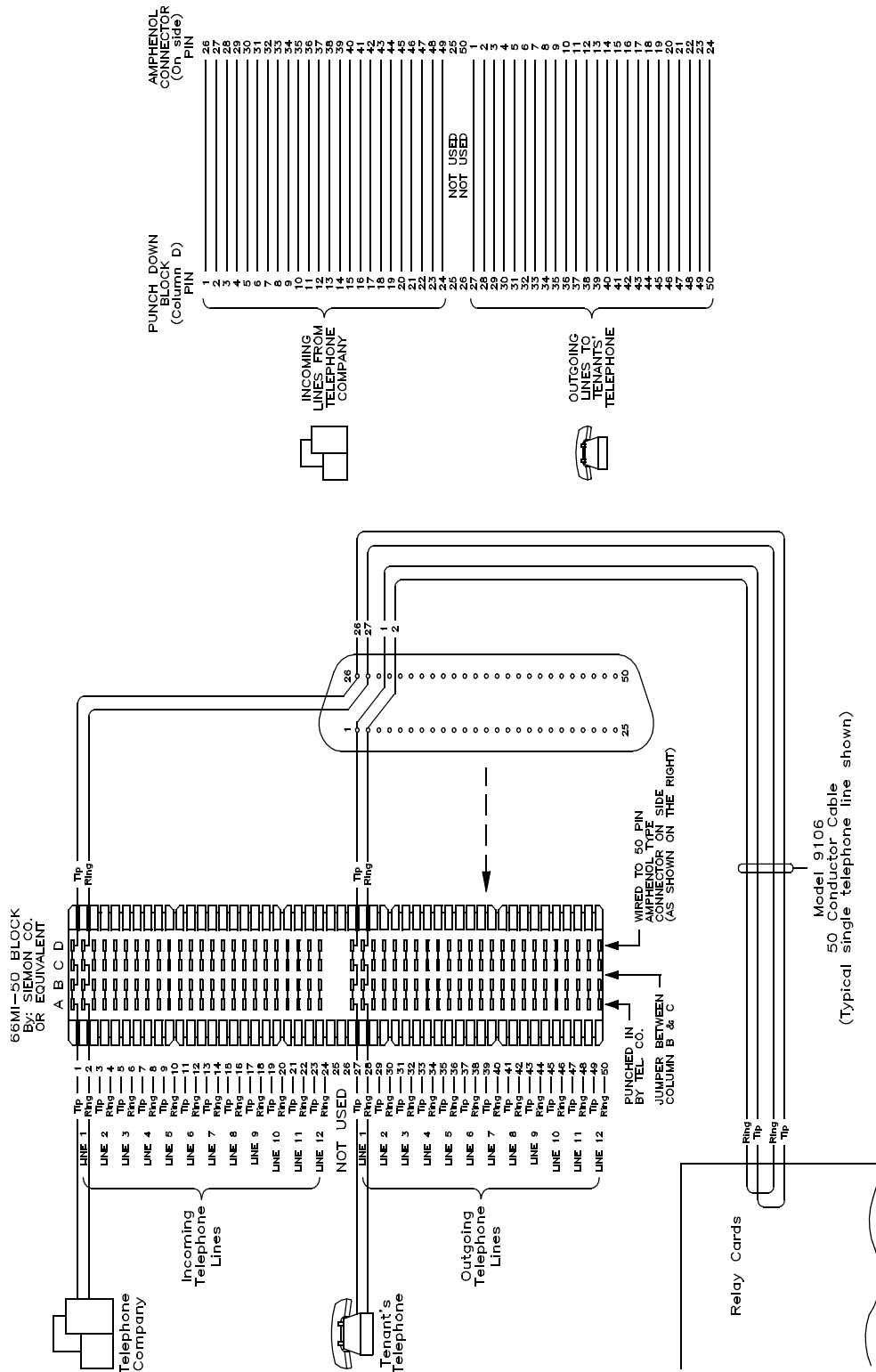


Figure 50. RJ-71C Punch-Down Block Wiring Configuration

**Table 7: RJ-71C Punch-Down Block Identification Form**

Relay Cabinet No. \_\_\_\_ of \_\_\_\_ Decoder/Mother Board No. \_\_\_\_

Relay Card/ Amp. Jack #	Telephone Number	Block Pins Tel. Co./Res.	Apt. #	Dial Code	Relay/ Line #	Relay Card/ Amp. Jack #	Telephone Number	Block Pins Tel. Co./Res.	Apt. #	Dial Code	Relay/ Line #
1		1,2/27,28			0001	5		1,2/27,28			0049
		3,4/29,30			0002			3,4/29,30			0050
		5,6/31,32			0003			5,6/31,32			0051
		7,8/33,34			0004			7,8/33,34			0052
		9,10/35,36			0005			9,10/35,36			0053
		11,12/37,38			0006			11,12/37,38			0054
		13,14/39,40			0007			13,14/39,40			0055
		15,16/41,42			0008			15,16/41,42			0056
		17,18/43,44			0009			17,18/43,44			0057
		19,20/45,46			0010			19,20/45,46			0058
		21,22/47,48			0011			21,22/47,48			0059
		23,24/49,50			0012			23,24/49,50			0060
2		1,2/27,28			0013	6		1,2/27,28			0067
		3,4/29,30			0014			3,4/29,30			0062
		5,6/31,32			0015			5,6/31,32			0063
		7,8/33,34			0016			7,8/33,34			0064
		9,10/35,36			0017			9,10/35,36			0065
		11,12/37,38			0018			11,12/37,38			0066
		13,14/39,40			0019			13,14/39,40			0067
		15,16/41,42			0020			15,16/41,42			0068
		17,18/43,44			0021			17,18/43,44			0069
		19,20/45,46			0022			19,20/45,46			0070
		21,22/47,48			0023			21,22/47,48			0071
		23,24/49,50			0024			23,24/49,50			0072

**Table 7: RJ-71C Punch-Down Block Identification Form (Continued)**

Relay Cabinet No. \_\_\_\_\_ of \_\_\_\_\_ Decoder/Mother Board No. \_\_\_\_\_

Relay Card/ Amp. Jack #	Telephone Number	Block Pins Tel. Co./Res.	Apt. #	Dial Code	Relay/ Line #	Relay Card/ Amp. Jack #	Telephone Number	Block Pins Tel. Co./Res.	Apt. #	Dial Code	Relay/ Line #
3		1,2/27,28			0025	7		1,2/27,28			0073
		3,4/29,30			0026			3,4/29,30			0074
		5,6/31,32			0027			5,6/31,32			0075
		7,8/33,34			0028			7,8/33,34			0076
		9,10/35,36			0029			9,10/35,36			0077
		11,12/37,38			0030			11,12/37,38			0078
		13,14/39,40			0031			13,14/39,40			0079
		15,16/41,42			0032			15,16/41,42			0080
		17,18/43,44			0033			17,18/43,44			0081
		19,20/45,46			0034			19,20/45,46			0082
		21,22/47,48			0035			21,22/47,48			0083
		23,24/49,50			0036			23,24/49,50			0084
4		1,2/27,28			0037	8		1,2/27,28			0085
		3,4/29,30			0038			3,4/29,30			0086
		5,6/31,32			0039			5,6/31,32			0087
		7,8/33,34			0040			7,8/33,34			0088
		9,10/35,36			0041			9,10/35,36			0089
		11,12/37,38			0042			11,12/37,38			0090
		13,14/39,40			0043			13,14/39,40			0091
		15,16/41,42			0044			15,16/41,42			0092
		17,18/43,44			0045			17,18/43,44			0093
		19,20/45,46			0046			19,20/45,46			0094
		21,22/47,48			0047			21,22/47,48			0095
		23,24/49,50			0048			23,24/49,50			0096

## 5.4 Updating Firmware

After completion of the TX3-NSL-8M NSL Main Controller wiring and configuration, use the TX3-MSW Configuration Software to complete the firmware update.

### To update firmware

1. Turn the power OFF by using SW1 on the bottom right side of the card access controller board.
2. Short JW1 and JW2 using a jumper.
3. Turn the power ON.
4. Wait for 15 seconds.
5. Turn power OFF and remove jumper JW2.
6. Connect the USB cable to the card access controller board.
7. Turn the power ON.
8. Proceed with the firmware update using the Configurator software.
9. When you are finished updating the firmware, turn the power OFF.
10. Unplug the USB cable.
11. Turn the power back ON.

# 6 Adding Controllers and Accessories

This chapter provides information about adding additional controllers on the same network as the Telephone Access System.

## This chapter explains

- Add a Controller
- Install the TX3-P300-HA Card Reader

## 6.1 Add a Controller

The TX3 telephone access system may be integrated with other controllers, such as the TX3-CX Card Access system and Elevator Restriction Unit, through a peer-to-peer connection via the RS-485 bus, an Ethernet TPC/IP network, or a combination of RS-485 and Ethernet networks.

Connecting a controller to an RS-485 network requires that the controller have a unique ID address on the RS-485 network (valid addresses range from 1 to 63). See the installation manual for your controller for instructions on how to set the ID address for your controller.

To connect a controller to an Ethernet network, the controller must have an IP Module. Once the controller is connected to the Ethernet network and has an IP address, the controller is recognized as a Main Node on the TX3 system.

To create a combination Ethernet and RS-485 network, connect one or more controllers to the RS-485 network on a Main Node. The controllers connecting to the Main Node's RS-485 network are Secondary Nodes. Each controller on the RS-485 network (including the Main Node) must have a unique ID address on the RS-485 network. See the installation manual for your controller for instructions on how to set the ID address for your controller.

---

**Note:** Ensure that each controller has a unique address (IP address, RS-485 ID, or both) on the network it is connected to.

---

### Integrate another controller on an RS-485 network

1. Ensure the Telephone Access System and the controller are set up and ready for operation.

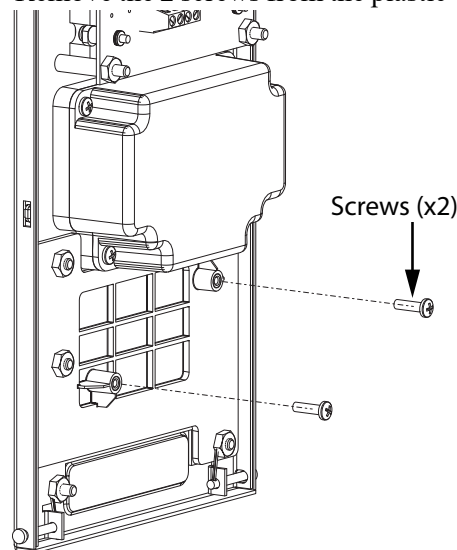
2. Turn the power OFF for all units on the network.
3. Connect the controller to the Telephone Access System via the RS-485 bus using the RS-485 connectors.
4. Turn the power ON for all units on the network.
5. Connect the PC to either the Telephone Access System or controller using the USB port.
6. Use the TX3 Configurator Program to add and configure the controller to the network.

## 6.2 Install the TX3-P300-HA Card Reader

This section explains how to install TX3-P300-HA in these models:

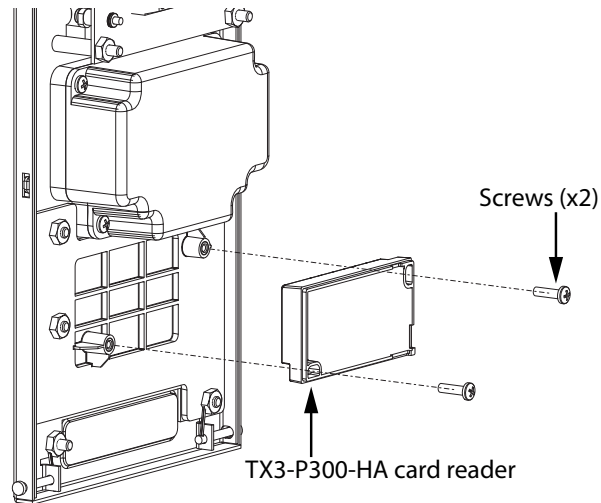
TX3-200-4U-C	TX3-200-8U-C	TX3-200-8C-C
TX3-2000-4U-C	TX3-1000-8U-C	TX3-1000-8C-C
TX3-1000-4U-C	TX3-2000-8U-C	TX3-2000-8C-C
TX3-2000-4UR-C	TX3-1000-8UI-C	TX3-2000-8CR-C
	TX3-2000-8UR-C	

1. Disconnect the power.
2. Remove the 2 screws from the plastic window on the inside of the door.



**Figure 51. Remove the 2 screws**

3. Attach the card reader with the same screws.



**Figure 52. Install TX3-P300-HA**

4. See LT-980 TX3-CX Card Access System Installation for instructions on connecting the card reader to the TX3-CX Card Access system.

# 7 Specifications

<p><b>External Power Supply</b></p> <p>Mircom Model PS-4. 16 VAC/ 40 VA, CSA approved Class 2 Power Transformer          Mircom Model PS-4P. 16 VAC/ 40 VA, CSA approved Class 2 Power Transformer, plug-in          Input voltage: 105 VAC to 128 VAC  <b>Note:</b> Maximum power consumption for an 8-line by 20 character LCD TX3 Lobby Control Unit is 6.2 Watts.</p>
<p><b>Door Strikes</b></p> <p>Select the appropriate door strike as required by your system applications. We recommend using the following Mircom door strikes below and its compatible power transformer.</p> <ul style="list-style-type: none"> <li>• <b>Mircom Model M-10.</b> DC (silent) or AC (buzzing) Door Strike. (Use PS-3B transformer)</li> </ul> <p><b>Note:</b> The door strike must have its own separate power transformer. Do not tap or use the system power transformers.</p> <p>The maximum supply for the AC or DC Input Door Strike must not exceed:</p> <ul style="list-style-type: none"> <li>• 28 VAC / 1 A max</li> <li>• 30 VDC / 1 A max</li> </ul>
<p><b>Outputs 2-4</b></p> <p>Relays with these contact ratings:</p> <ul style="list-style-type: none"> <li>• 125 VAC / 2 A</li> <li>• 30 VDC / 1 A</li> </ul>
<p><b>Telephone Lines</b></p> <p>Use only Loop Start telephones (not ground start), check with your local telephone company.</p>
<p><b>Post Office Lock</b></p> <p>The system has a built-in micro switch and mounting hardware for a postal lock installation. If a postal service is required, contact the Post Office to obtain the lock.</p>



**Compatible Modems**

- TrendNet TFM-560U High Speed USB 2.0 Fax Modem
- TrendNet TFM-561U High Speed USB 2.0 Fax Modem
- StarTech USB56KEM2 56k V.92 USB Fax Modem
- Zoom 56K V.92 56K USB Mini External Fax Modem
- USRobotics USR5639 56K USB Softmodem
- USB Fax Modem HT-M310 or CX-FU02

**Operating Temperature**

50 °C (122 °F) to -20 °C (-4 °F)

For temperatures where the Telephone Access System will operate below 0 °C (32 °F) at any time, install the TH-102K Thermostat Heater within the enclosure.

# 8 Resident Operating Instructions

This chapter describes the Telephone Access System operating instructions for use by the resident.

## **This chapter explains**

- NSL Resident Operating Instructions
- ADC Resident Operating Instructions

## 8.1 NSL Resident Operating Instructions

Mircom's state-of-the-art door entry system provides you and your guest with an increased level of confidence and security.

The TX3 Telephone Access system operates with your existing telephone. Your guest dials your code number or selects your name by scrolling through the electronic directory on the Entry unit, causing your telephone to ring.

---

**Note:** The telephone keypad numbers described in this chapter may be different for your system. If the keypad numbers do not perform as described, check with your building administrator to get the correct values.

---

### 8.1.1 Granting Access

When you answer your telephone, you will be in communication with your guest.

#### To unlock the main door

- Press " 9 " on your telephone keypad

#### To unlock the auxiliary door

- Press " 6 " on your telephone keypad

#### To refuse entry

- Hang up **or**
- Press "4"

### 8.1.2 Call Waiting Feature

---

**Note:** The Call Waiting Feature is available only on NSL systems.

---

When a guest places a call to you from the Lobby Control Unit while you are engaged in a conversation on your outside telephone line, you will hear a distinct tone.

**To answer the call**

1. Briefly push the call waiting key, “2”, to answer the call. This action automatically places the outside telephone line "on hold".
2. While on-line with your guest, you can open the main door by dialling "9".

Pressing “9”, “6” or “4” automatically reconnects to the previously "on hold" caller. In a similar manner, you can answer an outside call while talking to the guest in the lobby.

---

**Note:** You will be disconnected if you attempt to place your guest "on hold".

---

**8.1.3 Keyless Entry Codes**

The keyless code is a confidential number assigned to each resident by the building administrator to let you open the front lobby door without using a key.

**To unlock the front door**

1. Press “0”. The keyless code prompt appears.
2. Enter the keyless code. The front door unlocks.

## 8.2 ADC Resident Operating Instructions

Mircom's state-of-the-art door entry system provides you and your guest with an increased level of confidence and security.

The TX3 Telephone Access system operates with your existing telephone. Your guest simply dials your code number or selects your name by scrolling through the electronic directory on the Entry unit, causing your telephone to ring.

---

**Note:** The telephone keypad numbers described in this chapter may be different for your system. If the keypad numbers do not perform as described, check with your building administrator to get the correct values.

---

### 8.2.1 Granting Access

When you answer your telephone, you will be in communication with your guest.

#### To unlock the main door

- Press " 9 " on your telephone keypad

#### To unlock the auxiliary door

- Press " 6 " on your telephone keypad

#### To refuse entry

- Hang up **or**
- Press "4"

### 8.2.2 Keyless Entry Codes

The keyless code is a confidential number assigned to each resident by the building administrator to let you open the front lobby door without using a key.

#### To unlock the front door

1. Press "0". The keyless code prompt appears.
2. Enter the keyless code. The front door unlocks.

## Warranty & Warning Information

### WARNING!

Please read this document **CAREFULLY**, as it contains important warnings, life-safety, and practical information about all products manufactured by the Mircom Group of Companies, including Mircom and Secutron branded products, which shall include without limitation all fire alarm, nurse call, building automation and access control and card access products (hereinafter individually or collectively, as applicable, referred to as “**Mircom System**”).

### NOTE TO ALL READERS:

1. **Nature of Warnings.** The within warnings are communicated to the reader out of an abundance of caution and create no legal obligation for Mircom Group of Companies, whatsoever. Without limiting the generality of the foregoing, this document shall NOT be construed as in any way altering the rights and obligations of the parties, governed by the legal documents that apply in any given circumstance.
2. **Application.** The warnings contained in this document apply to all Mircom System and shall be read in conjunction with:
  - a. the product manual for the specific Mircom System that applies in given circumstances;
  - b. legal documents that apply to the purchase and sale of a Mircom System, which may include the company’s standard terms and conditions and warranty statements;
  - c. other information about the Mircom System or the parties’ rights and obligations as may be application to a given circumstance.
3. **Security and Insurance.** Regardless of its capabilities, no Mircom System is a substitute for property or life insurance. Nor is the system a substitute for property owners, renters, or other occupants to act prudently to prevent or minimize the harmful effects of an emergency situation. Building automation systems produced by the Mircom Group of Companies are not to be used as a fire, alarm, or life-safety system.

### NOTE TO INSTALLERS:

All Mircom Systems have been carefully designed to be as effective as possible. However, there are circumstances where they may not provide protection. Some reasons for system failure include the following. As the only individual in contact with system users, please bring each item in this warning to the attention

of the users of this Mircom System. Failure to properly inform system end-users of the circumstances in which the system might fail may result in over-reliance upon the system. As a result, it is imperative that you properly inform each customer for whom you install the system of the possible forms of failure:

4. **Inadequate Installation.** All Mircom Systems must be installed in accordance with all the applicable codes and standards in order to provide adequate protection. National standards require an inspection and approval to be conducted by the local authority having jurisdiction following the initial installation of the system and following any changes to the system. Such inspections ensure installation has been carried out properly.
5. **Inadequate Testing.** Most problems that would prevent an alarm a Mircom System from operating as intended can be discovered by regular testing and maintenance. The complete system should be tested by the local authority having jurisdiction immediately after a fire, storm, earthquake, accident, or any kind of construction activity inside or outside the premises. The testing should include all sensing devices, keypads, consoles, alarm indicating devices and any other operational devices that are part of the system.

## NOTE TO USERS:

All Mircom Systems have been carefully designed to be as effective as possible. However, there are circumstances where they may not provide protection. Some reasons for system failure include the following. The end user can minimize the occurrence of any of the following by proper training, testing and maintenance of the Mircom Systems:

6. **Inadequate Testing and Maintenance.** It is imperative that the systems be periodically tested and subjected to preventative maintenance. Best practices and local authority having jurisdiction determine the frequency and type of testing that is required at a minimum. Mircom System may not function properly, and the occurrence of other system failures identified below may not be minimized, if the periodic testing and maintenance of Mircom Systems is not completed with diligence and as required.
7. **Improper Operation.** It is important that all system users be trained in the correct operation of the alarm system and that they know how to respond when the system indicates an alarm. A Mircom System may not function as intended during an emergency situation where the user is unable to operate a panic or emergency switch by reason of permanent or temporary physical disability, inability to reach the device in time, unfamiliarity with the correct operation, or related circumstances.

8. **Insufficient Time.** There may be circumstances when a Mircom System will operate as intended, yet the occupants will not be protected from the emergency due to their inability to respond to the warnings in a timely manner. If the system is monitored, the response may not occur in time enough to protect the occupants or their belongings.
9. **Carelessness or Safety Hazards.** Moreover, smoke detectors may not provide timely warning of fires caused by carelessness or safety hazards such as smoking in bed, violent explosions, escaping gas, improper storage of flammable materials, overloaded electrical circuits or children playing with matches or arson.
10. **Power Failure.** Some Mircom System components require adequate electrical power supply to operate. Examples include: smoke detectors, beacons, HVAC, and lighting controllers. If a device operates only by AC power, any interruption, however brief, will render that device inoperative while it does not have power. Power interruptions of any length are often accompanied by voltage fluctuations which may damage Mircom Systems or other electronic equipment. After a power interruption has occurred, immediately conduct a complete system test to ensure that the system operates as intended.
11. **Battery Failure.** If the Mircom System or any device connected to the system operates from batteries it is possible for the batteries to fail. Even if the batteries have not failed, they must be fully charged, in good condition, and installed correctly. Some Mircom Systems use replaceable batteries, which have a limited life-span. The expected battery life is variable and in part dependent on the device environment, usage and type. Ambient conditions such as high humidity, high or low temperatures, or large temperature fluctuations may reduce the expected battery life. Moreover, some Mircom Systems do not have a battery monitor that would alert the user in the event that the battery is nearing its end of life. Regular testing and replacements are vital for ensuring that the batteries function as expected, whether or not a device has a low-battery monitor.
12. **Physical Obstructions.** Motion sensors that are part of a Mircom System must be kept clear of any obstacles which impede the sensors' ability to detect movement. Signals being communicated by a Mircom System may not reach the receiver if an item (such as metal, water, or concrete) is placed on or near the radio path. Deliberate jamming or other inadvertent radio signal interference can also negatively affect system operation.
13. **Wireless Devices Placement Proximity.** Moreover all wireless devices must be a minimum and maximum distance away from large metal objects, such as refrigerators. You are required to consult the specific Mircom System manual and application guide for any maximum distances required between devices and suggested placement of wireless devices for optimal functioning.
14. **Failure to Trigger Sensors.** Moreover, Mircom Systems may fail to operate as intended if motion, heat, or smoke sensors are not triggered.



- a. Sensors in a fire system may fail to be triggered when the fire is in a chimney, walls, roof, or on the other side of closed doors. Smoke and heat detectors may not detect smoke or heat from fires on another level of the residence or building. In this situation the control panel may not alert occupants of a fire.
  - b. Sensors in a nurse call system may fail to be triggered when movement is occurring outside of the motion sensors' range. For example, if movement is occurring on the other side of closed doors or on another level of the residence or building the motion detector may not be triggered. In this situation the central controller may not register an alarm signal.
15. **Interference with Audible Notification Appliances.** Audible notification appliances may be interfered with by other noise sources such as stereos, radios, televisions, air conditioners, appliances, or passing traffic. Audible notification appliances, however loud, may not be heard by a hearing-impaired person.
16. **Other Impairments.** Alarm notification appliances such as sirens, bells, horns, or strobes may not warn or waken a sleeping occupant if there is an intervening wall or door. It is less likely that the occupants will be alerted or awakened when notification appliances are located on a different level of the residence or premise.
17. **Software Malfunction.** Most Mircom Systems contain software. No warranties are provided as to the software components of any products or stand-alone software products within a Mircom System. For a full statement of the warranties and exclusions and limitations of liability please refer to the company's standard Terms and Conditions and Warranties.
18. **Telephone Lines Malfunction.** Telephone service can cause system failure where telephone lines are relied upon by a Mircom System. Alarms and information coming from a Mircom System may not be transmitted if a phone line is out of service or busy for a certain period of time. Alarms and information may not be transmitted where telephone lines have been compromised by criminal tampering, local construction, storms or earthquakes.
19. **Component Failure.** Although every effort has been made to make this Mircom System as reliable as possible, the system may fail to function as intended due to the failure of a component.
20. **Integrated Products.** Mircom System might not function as intended if it is connected to a non-Mircom product or to a Mircom product that is deemed non-compatible with a particular Mircom System. A list of compatible products can be requested and obtained.

# Warranty

**Purchase of all Mircom products is governed by:**

<https://www.mircom.com/product-warranty>

<https://www.mircom.com/purchase-terms-and-conditions>

<https://www.mircom.com/software-license-terms-and-conditions>

## Special Notices

### Product Model Number: TX3

AC REN (U.S.): 0.0B

AC REN (CANADA): 0.0

### Complies With

#### Federal Communications Commission (FCC):

- TIA-968-A Technical requirement for connection of equipment to the telephone network.
- CFR 47, Part 15, Subpart B, Class B
- Unintentional Radiators

#### Industry Canada (IC):

- Terminal attachment programme
- CS-03, Issue 8 - Certification Specifications
- ICES-003, ISSUE 4, CLASS B
- Verification Authorization - Digital Apparatus

### Registration Numbers

FCC (U.S.): 1M8TE00BTX3

IC (Canada): 1156A-TX3

### Industry Canada Notice for all TX3 Products Sold in Canada

The Industry Canada label identifies certified equipment. This certification means that the equipment meets certain telecommunications network protective, operational, and safety requirements. Industry Canada does not guarantee the equipment will operate to the user's satisfaction. Before installing this equipment, users should ensure that it is permissible to be connected to the facilities of the local telecommunication company. The equipment must also be installed using an acceptable method of connection. The customer should be aware that compliance with the above conditions may not prevent degradations of service in some situations.

Repairs to certified equipment should be made by an authorized Canadian maintenance facility designated by the supplier. Any repairs or alteration made by the user to this equipment, or equipment malfunctions, may give the telecommunications company cause to request the user to disconnect the equipment. Users should ensure for their own protection that the earth ground connections of the power utility, telephone lines and internal metallic water pipe system, if present, are connected together. This is necessary both for proper operation and for protection.

---

**Caution:** Users should not attempt to make such connections themselves, but should contact the appropriate electric inspection authority, or electrician, as appropriate.

---

**Note:** The Ringer Equivalence Number (REN) assigned to each terminal device provides an indication of the maximum number of terminals allowed to be connected to a telephone interface. The termination on an interface may consist of any combination of devices subject only to the requirement that the sum of the RENs of all the devices does not exceed five.

---

## FCC Notice for all TX3 Products Sold in the U.S.A.

### Type of Service

The TX3 is designed to be used on standard device telephone lines. It connects to the telephone line by means of a standard jack called the USOC RJ-11C (or USOC FJ45S). Connection to telephone company-provided coin service (central office implemented systems) is prohibited. Connection to party lines service is subject to state tariffs.

### Telephone Company Procedures

The goal of the telephone company is to provide you with the best service it can. In order to do this, it may occasionally be necessary for them to make changes in their equipment, operations or procedures. If these changes might affect your service or the operation of your equipment, the telephone company will give you notice, in writing, to allow you to make any changes necessary to maintain uninterrupted service.

In certain circumstances, it may be necessary for the telephone company to request information from you concerning the equipment which you have connected to your telephone line. Upon request of the telephone company, provide the FCC registration number and the ringer equivalence number (REN); both of these items are listed on the equipment label. The sum of all of the RENs

on your telephone lines should be less than five in order to assure proper service from the telephone company. In some cases, a sum of five may not be useable on a given line.

### **Changes to Telephone Service**

The telephone company may make changes in its facilities, equipment, operations or procedures that could affect the operation of the equipment. If this happens the telephone company will provide advance notice in order for you to make necessary modifications to maintain uninterrupted service.

### **Ringer Equivalence Number**

The REN is used to determine the number of devices that may be connected to a telephone line. Excessive RENs on a telephone line may result in the devices not ringing in response to an incoming call. In most but not all areas, the sum of RENs should not exceed five (5.0). To be certain of the number of devices that may be connected to a line, as determined by the total RENs, contact the local telephone company. For products approved after July 23, 2001, the REN for this product is Customer Information 3 July 2003 part of the product identifier that has the format US:AAAEQ##TXXXX. The digits represented by ## are the REN without a decimal point (e.g., 03 is a REN of 0.3). For earlier products, the REN is separately shown on the label.

### **If Problems Arise**

If any of your telephone equipment is not operating properly, you should immediately remove it from your telephone line, as it may cause harm to the telephone network. If the telephone company notes a problem, they may temporarily discontinue service. When practical, they will notify you in advance of this disconnection. If advance notice is not feasible, you will be notified as soon as possible. When you are notified, you will be given the opportunity to correct the problem and informed of your right to file a complaint with the FCC. Contact your telephone company if you have any questions about your telephone line. In the event repairs are ever needed on the Communicator, they should be performed by Mircom or an authorized representative of Mircom. For information contact Mircom at the address and telephone numbers in paragraph 1.9.

If this equipment, TX3 Telephone System, causes harm to the telephone network, the telephone company will notify you in advance that temporary discontinuance of service may be required. But if advance notice isn't practical, the telephone company will notify the customer as soon as possible. Also, you will be advised of your right to file a complaint with the FCC if you believe it is necessary.

## Product Identifier

This equipment complies with Part 68 of the FCC rules and the requirements adopted by the ACTA. On the back of the front panel cover of this equipment is a label that contains, among other information, a product identifier in the format US:AAAEQ##TXXXX. If requested, this number must be provided to the telephone company.

## Telephone Connection

A plug and jack used to connect this equipment to the premises wiring and telephone network must comply with the applicable FCC Part 68 rules and requirements adopted by the ACTA. You are responsible for installing a compliant telephone cord and modular plug into this product as described in this manual. It is designed to be connected to a compatible modular jack that is also compliant. See installation instructions for details.

## Equipment Failure

If trouble is experienced with the TX3 Telephone/Card Access System, for repair or warranty information, please contact Mircom using the numbers paragraph 1.9. If the equipment is causing harm to the telephone network, the telephone company may request that you disconnect the equipment until the problem is resolved.

## Use With Alarm Auto Dialers

If your institution has specially wired alarm equipment connected to the telephone line, ensure the installation of the TX3 Telephone/Card Access System does not disable your alarm equipment. If you have questions about what will disable alarm equipment, consult your telephone company or a qualified installer.