

MODEL SLS SLIDING SHELF

PARTS IDENTIFICATION

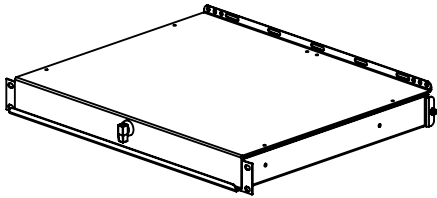

SLIDING SHELF

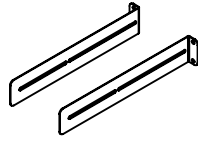

SIDE BRACKETS

Install the sliding shelf on the cabinet front mounting rails with 10-32 x 7/8" pan head screws (qty:4).

10-32 x 7/8" screws

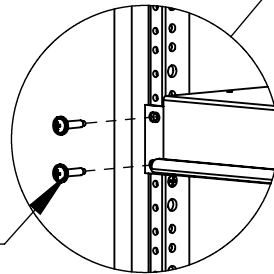

10-32 tapped mounting rails on EIA hole centers.

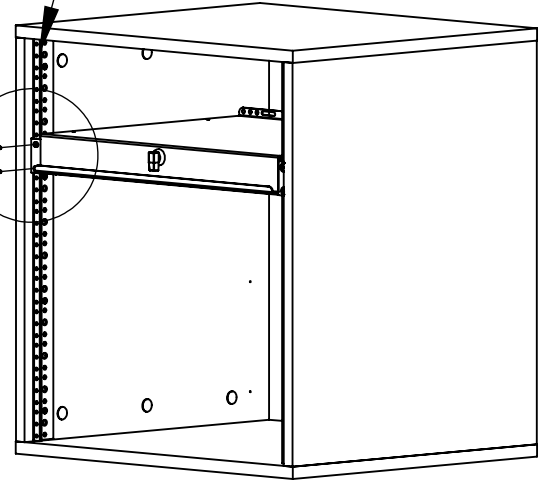

When installing the sliding shelf in a wood cabinet with no rear mounting rails loosen the wing nut on the rear of the shelf and extend the rear brackets to touch the inside of the cabinet. Make sure that the shelf is level and drill a hole in the cabinet matching the hole in the rear bracket. Insert a #8 x 5/8" wood screw in each hole (qty:2). Tighten the wing nuts when finished.

rear bracket

rear of cabinet

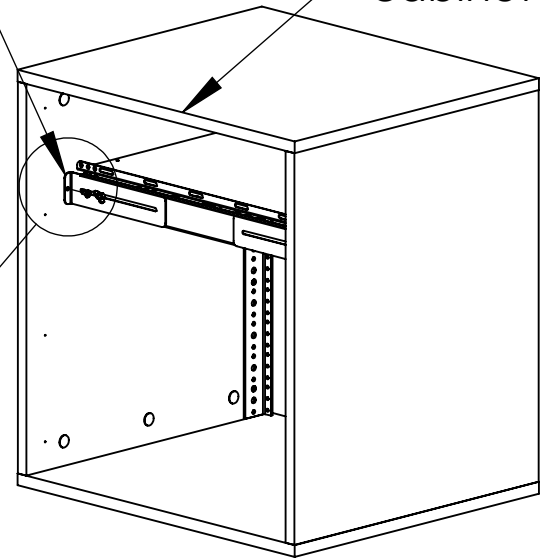

8-32 wing nut

mounting hole

#8 x 5/8" wood screw

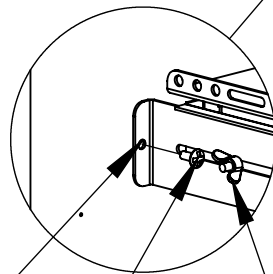

HARDWARE SUPPLIED:

- 8 10-32 X 7/8" PHWHD PP (P/N: 10569)
- 2 8-32 X 5/16" TRUSS HD SCREW (P/N: 1875)
- 2 8-32 KEPS NUTS (P/N: 2370)
- 4 PR. VELCRO TABS (P/N: 19434)
- 2 #8 X 5/8" WOOD SCREW (P/N: 16004)

P/N: 19426

MODEL SLS SLIDING SHELF

The side brackets must be used when installing the sliding shelf in a cabinet that has rear mounting rails.

Install the front of the shelf on the front mounting rails as previously shown. Align the holes in the side brackets with the matching tapped holes in the rear mounting rails. Install a 10-32 x 7/8" pan head screw in each hole (qty:4).

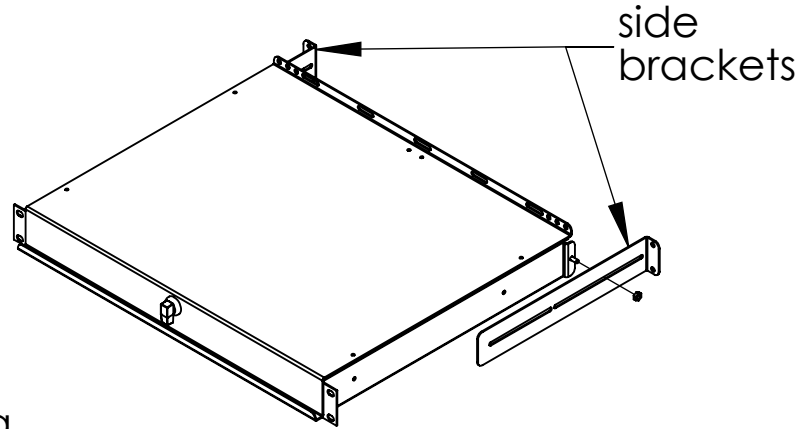

Loosen the wing nuts and slide the rear brackets out to touch the side brackets. Center the hole in each rear bracket over the slot in the side bracket (as shown) and insert an 8-32 x 5/16" truss head screw through the aligned holes (qty:2).

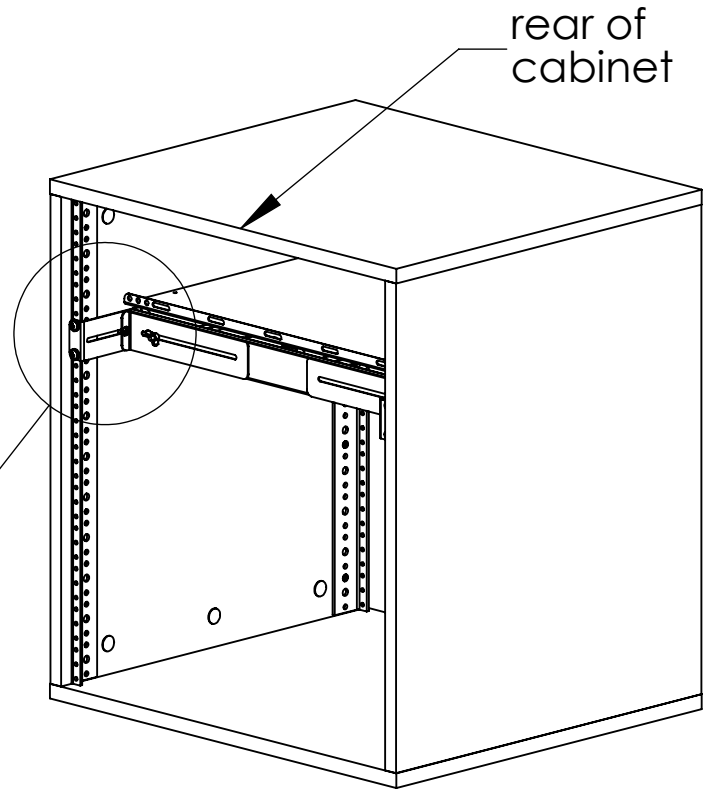

Secure each screw with an 8-32 keps nut (qty:2). When finished, tighten the wing nuts loosened in the previous step.

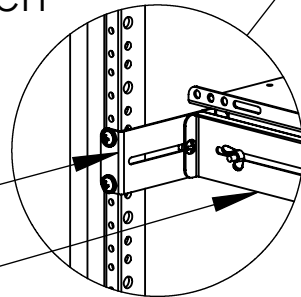

side bracket

rear bracket

Install the coarse part of the Velcro tab to the center of the feet on the bottom of the unit. If the equipment has no feet install the tab as close as possible to the outside corners of the unit.

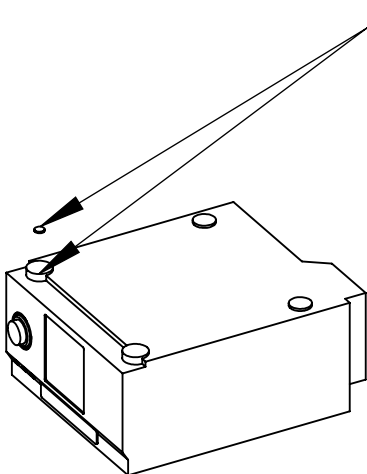

Install the soft piece of the Velcro tab to the center of the feet on the bottom of the unit. If the equipment has no feet install the tab as close as possible to the outside corners of the unit.

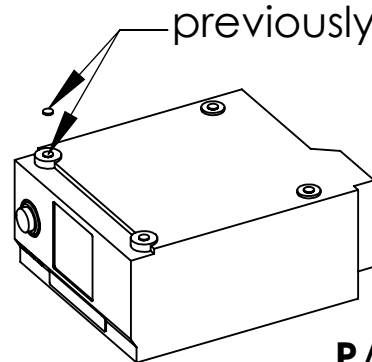

P/N: 19426