



# User Manual

---



# TABLE OF CONTENTS

1.0	About This Product.....	6
1.1	Product Description.....	6
1.2	Simplified Description of Services .....	6
1.2.1	Messaging .....	6
1.2.2	Management.....	6
1.2.3	Shutdown - Future Enhancement.....	6
1.3	Security Protocols Supported.....	7
2.0	Quick Start .....	8
2.1	Physical Installation .....	8
2.1.1	Hardware Installation .....	8
2.2	Access to the Web Interface .....	8
2.2.1	Connecting to the Web Interface.....	8
2.2.2	Logging In to the iSite PRO Web Interface.....	9
2.2.3	Finding MAC Address of iSite PRO.....	9
3.0	Web Interface Navigation .....	10
3.1	Overview.....	10
3.2	Supported Web Browsers .....	10
3.3	Logging On .....	10
3.4	Dashboard .....	11
3.4.1	UPS Status Window.....	11
3.4.2	Current Battery Charge Level .....	11
3.4.3	Battery Lifespan.....	11
3.4.4	Support Info .....	11
3.4.5	Download Support Info .....	11
3.4.6	Line Voltage (Volts).....	11
3.4.7	Percent Load .....	11
3.5	Reports.....	12

---

3.5.1	Time Stamped Events.....	12
3.5.2	Historical Data .....	13
3.6	UPS Settings .....	15
3.6.1	Status Tab .....	15
3.6.2	Configuration Tab .....	17
3.6.3	Diagnostics Tab .....	19
3.6.4	Control Tab .....	20
3.6.5	PDU Control Tab .....	21
3.6.6	PDU Configuration Screen.....	22
3.6.7	About Tab .....	23
3.7	Network Screen .....	24
3.8	Network Advanced Screen.....	25
3.8.1	Date/Time Settings Tab .....	25
3.8.2	SNMP Tab .....	26
3.8.3	LDAP Client Settings .....	29
3.8.4	Email Settings.....	31
3.9	Users Screen .....	33
3.9.1	Edit/Add User Account.....	34
3.10	Utilities .....	35
3.10.1	File Upload Tab .....	35
3.10.2	Backup/Restore Tab .....	36
3.10.3	Factory Reset Tab .....	36
3.10.4	Reboot Device Tab .....	36
3.11	Modbus Server .....	37
3.11.1	Modbus/RTU Wiring.....	37
3.11.2	Modbus/IP Server Settings .....	38
3.11.3	Modbus/RTU Server Settings .....	38
3.11.4	Modbus Register Map.....	38

3.12	Environment Sensors.....	39
3.12.1	Environment Sensor Kit Components .....	39
3.12.2	Environment Hardware Specifications .....	40
3.12.3	Hardware Installation .....	41
3.12.4	Environment Sensor View.....	42
3.12.5	Environment Sensor Configuration .....	44
3.12.6	Environment Sensor Inputs.....	46
3.12.7	Environment Sensor Output.....	47
3.12.8	Environment Sensor Triggers .....	47
3.13	System Info.....	47
3.14	User Profile.....	47
3.15	Logout.....	47
4.0	Recovery .....	48
4.1	USB Setup/Login .....	48
4.2	Administrator Credentials.....	48
4.2.1	Username and Password.....	48
4.2.2	Finding MAC Address of the iSite PRO.....	49
4.3	Reset Options.....	49
4.3.1	Reset Default User.....	50
4.3.2	Reset Network Settings .....	50
4.3.3	Reset To Factory Defaults .....	50
4.3.4	Reboot Device .....	50
5.0	Application Programming Interfaces (APIs) .....	50
5.1	HTTP/HTTPS REST .....	50
5.2	SNMP .....	50
6.0	Hardware Specifications.....	51
6.1	Specifications.....	51
6.2	Agency Approvals.....	51

Appendix A – UPS Alarm Detail .....52

## 1.0 About This Product

### 1.1 Product Description

The iSite PRO provides a variety of monitoring and management-related services for uninterruptible power systems (UPS) and associated auxiliary devices including SNMP Agent, web server, REST API, logging, email messaging and LDAP integration. All network protocols have secure options.

The iSite PRO with MODBUS Services option provides UPS Status information in MODBUS protocol for direct integration with Building Monitoring Systems via MODBUS RTU or MODBUS TCP/IP.

All AMETEK PowerVar UPS products are compatible with this iSite PRO.

### 1.2 Simplified Description of Services

#### 1.2.1 Messaging

- Send a message when events occur that may risk uptime of the protected systems.
- Messages can be sent via SNMP trap or email.
- Internet email services such as Gmail and Office 365 are supported.

#### 1.2.2 Management

- Integrate with IT-Network and Building Monitoring Systems.
- Update iSite PRO firmware files.
- Configure Network, Server, Agent and Device settings.
- View system status in real-time. View or export data and event logs.

#### 1.2.3 Shutdown - Future Enhancement

### 1.3 Security Protocols Supported

Support for TLS version 1.2 is provided for all secure protocols. This includes the following Algorithms:

- RSA
- DH-RSA
- DHE-RSA
- ECDH-RSA
- ECDHE-RSA
- DH-DSS
- DHE-DSS
- ECDH-ECDSA
- ECDSE-ECDSA
- PSK
- PSK-RSA
- DHE-PSK
- ECDHE-PSK
- SRP
- SRP-DSS
- SRP-RSA
- Kerberos

## 2.0 Quick Start

### 2.1 Physical Installation

#### 2.1.1 Hardware Installation

Before installing the iSite PRO, you should be familiar with the hardware installation. Installation notes are available the [iSite PRO page](#) on the Powervar Website.

### 2.2 Access to the Web Interface

#### 2.2.1 Connecting to the Web Interface

There are two ways to connect to the iSite PRO UI for configuration:

##### 1. *Using RJ45 Ethernet Port*

- a) Connect the iSite PRO to a standard Ethernet based Network.
- b) By default, the iSite PRO is configured to use DHCP. An IP Address will automatically be assigned if your network has a DHCP server. If your network does not have a DHCP server, then the iSite PRO will use the IP address of 192.168.1.100.
- c) To find the IP Address of the iSite PRO, download the Discovery Tool from the [iSite PRO page](#) on the Powervar Website.

##### 2. *Using the USB-OTG Port*

- a) Using an USB-A to Micro-USB B cable, connect the iSite PRO to a Laptop/PC.
- b) Using a web browser, go to <https://169.254.10.100>, this will access the USB Login Screen. This uses a default certificate which is unsigned, if your browser indicates that this is not valid, it is still safe to proceed, and the connection will be encrypted.



## 2.2.2 Logging In to the iSite PRO Web Interface

To log into the web iSite PRO web interface you must perform the following steps.

- a) Enter the default credentials:

**Username:** admin

**Password:** Adm1nXXXXXX where XXXXXX are the last six characters of the MAC address.

*For example, if the MAC Address is 00:20:82:FF:12:34, the default password would be Adm1nFF1234*

- b) Click “LOG IN” pushbutton
- c) By default, the admin user will have full access to the iSite PRO UI.

## 2.2.3 Finding MAC Address of iSite PRO

Reference the MAC address label above the ethernet port on the iSite PRO.

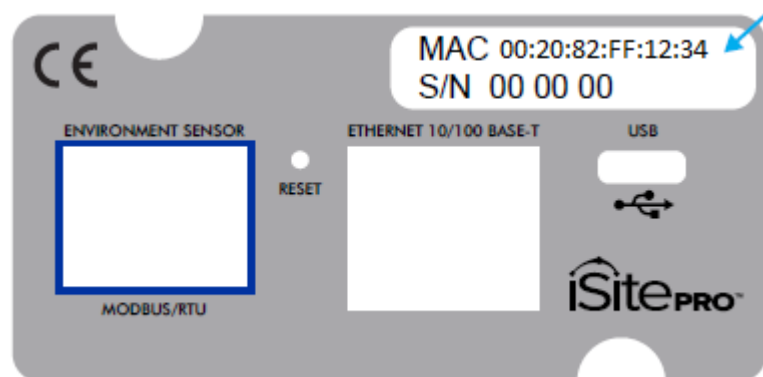

## 3.0 Web Interface Navigation

### 3.1 Overview

The Web user interface (UI) provides options to manage the UPS and the iSite PRO and to view the status of the UPS. This interface is available over HTTP or HTTPS based on the network configuration.

### 3.2 Supported Web Browsers

The iSite PRO Web interface is compatible with the following browsers:

- The latest release of Microsoft® Edge®
- The latest release of or Google® Chrome®
- The latest releases of Mozilla® Firefox®
- Other commonly available browsers might work but have not been fully tested.

### 3.3 Logging On

You can use the DNS name or the System IP address of the iSite PRO as the URL address. Use your case-sensitive username and password to log on. The default username is *admin* and the default password is in the format of *Adm1nXXXXXX*, where *XXXXXX* are the last 6 digits of the device MAC address.

### 3.4 Dashboard

The Dashboard page provides the overall status of the UPS.



#### 3.4.1 UPS Status Window

This window provides real-time information of the UPS. This information includes UPS Health Status and Event Alarms.

#### 3.4.2 Current Battery Charge Level

This icon displays the real-time current battery charge level.

#### 3.4.3 Battery Lifespan

This graph represents the real-time battery lifespan (years and months)

#### 3.4.4 Support Info

This section provides hardware information of the UPS and the iSite PRO.

#### 3.4.5 Download Support Info

Pressing this button will download a compressed file (.zip) that represents a snapshot of the current status of the UPS. This file can be sent to AMETEK Powervar technical support for further analysis.

#### 3.4.6 Line Voltage (Volts)

This meter displays the real-time Line Voltage to the UPS

#### 3.4.7 Percent Load

This meter represents the real-time Percent Load of the UPS

### 3.5 Reports

The Reports page displays data collected by the adapter and stored to its internal memory. The data is presented in two groups: Time Stamped Events and Historical Data.

#### 3.5.1 Time Stamped Events

Time Stamped Events are system or device events recorded with a date and time of occurrence. The adapter must be configured to synch with an NTP server for accurate time stamps. Events can be filtered by System, Device or Control types.

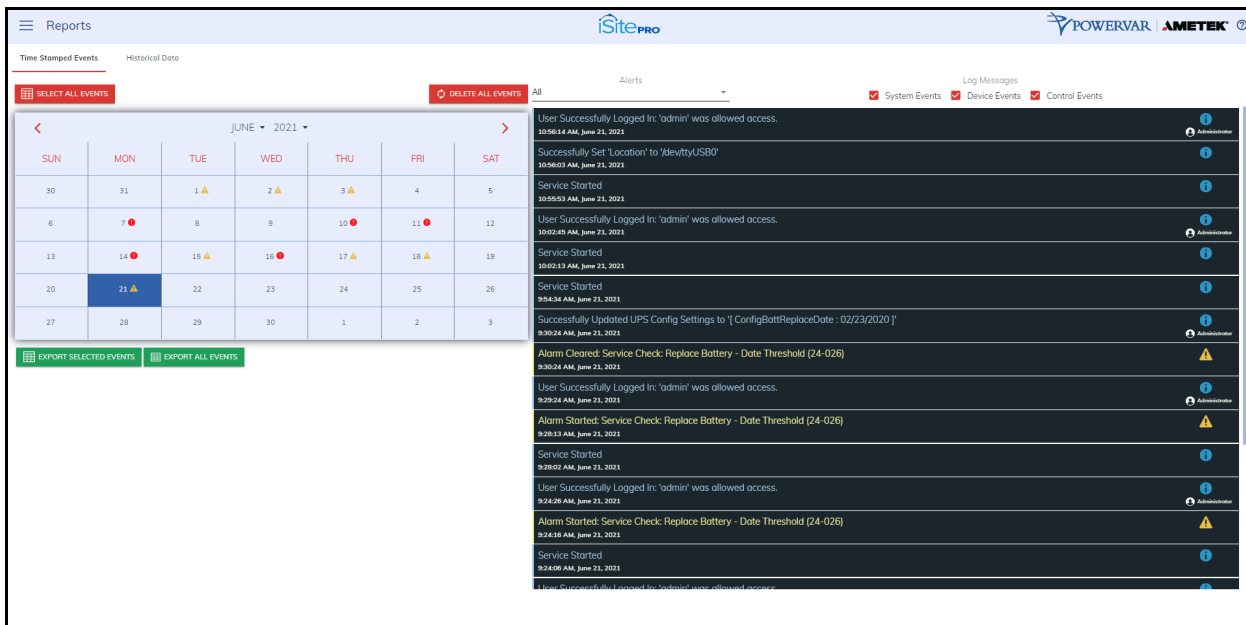

The screenshot shows the 'Reports' page in SitePRO. It features a navigation menu, a 'Time Stamped Events' tab, and a calendar for June 2021. The calendar highlights the 21st. Below the calendar are buttons for 'SELECT ALL EVENTS' and 'DELETE ALL EVENTS'. The main area displays a list of events with columns for time, description, and user. The events include:

- User Successfully Logged In: 'admin' was allowed access. (10:56:14 AM, June 21, 2021)
- Successfully Set 'Location' to '/dev/ttyUSB0' (10:56:03 AM, June 21, 2021)
- Service Started (10:55:53 AM, June 21, 2021)
- User Successfully Logged In: 'admin' was allowed access. (10:02:45 AM, June 21, 2021)
- Service Started (10:02:13 AM, June 21, 2021)
- Service Started (9:54:34 AM, June 21, 2021)
- Successfully Updated UPS Config Settings to [ ConfigBattReplaceDate : 02/23/2020 ] (9:50:24 AM, June 21, 2021)
- Alarm Cleared: Service Check: Replace Battery - Date Threshold (24-026) (9:20:24 AM, June 21, 2021)
- User Successfully Logged In: 'admin' was allowed access. (9:29:24 AM, June 21, 2021)
- Alarm Started: Service Check: Replace Battery - Date Threshold (24-026) (9:28:13 AM, June 21, 2021)
- Service Started (9:28:02 AM, June 21, 2021)
- User Successfully Logged In: 'admin' was allowed access. (9:24:28 AM, June 21, 2021)
- Alarm Started: Service Check: Replace Battery - Date Threshold (24-026) (9:24:18 AM, June 21, 2021)
- Service Started (9:24:08 AM, June 21, 2021)
- User Successfully Logged In: 'admin' was allowed access.

### 3.5.2 Historical Data

Historical Data is a record of measured electrical parameters and may be adjusted to sample certain items at specific intervals.

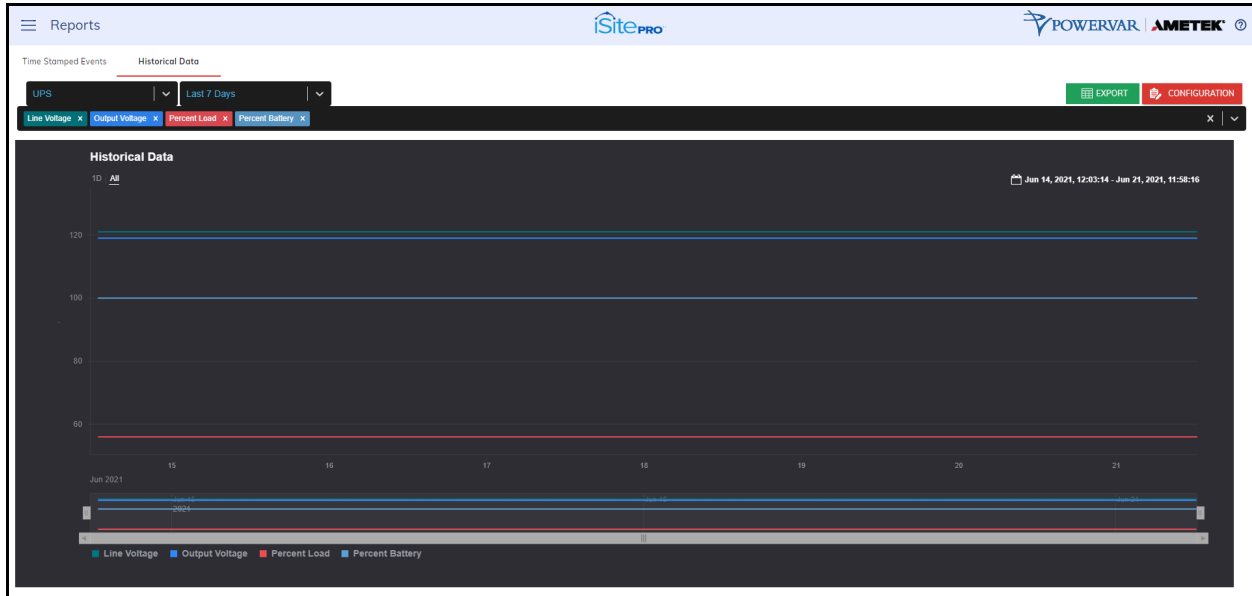

The available parameters are:

Historical Parameter	Units	Description
Battery Voltage	VDC	The DC Voltage measured at the battery or charger output.
Line Frequency	Hz.	The measurement of frequency of AC voltage on the input of the UPS.
Line Voltage	VAC	The measured AC line voltage.
Line Voltage Minimum	VAC	The minimum measured AC line voltage.
Line Voltage Maximum	VAC	The maximum measured AC line voltage.
Line Voltage – Log Period Minimum	VAC	The minimum line voltage recorded during the period since the last log entry was made.
Line Voltage – Log Period Maximum	VAC	The maximum line voltage recorded during the period since the last log entry was made.
Line Voltage – Log Period Average	VAC	The average line voltage recorded during the period since the last log entry was made.

Output Voltage	VAC	The measured UPS output voltage.
Percent Battery	%	Current percentage of the remaining total battery charge.
Percent Load	%	The percentage of the UPS capacity currently being supplied by the UPS
Percent Load – Period Minimum	%	The minimum percentage of the UPS capacity recorded since the last log entry was made.
Percent Load – Period Maximum	%	The maximum percentage of the UPS capacity recorded since the last log entry was made.
Percent Load – Period Average	%	The average percentage of the UPS capacity recorded since the last log entry was made.
Temperature	degC	The measurement of the temperature (degrees C) reported by the UPS. Generally, the temperature reported reflects a temperature reading within the UPS cabinet - typically either in the inverter (power electronics) region or in the battery compartment.

### Configuration Button

Press this button to adjust the data logging interval. The default is to log every 1 minute, which will allow for over 30 days of data.

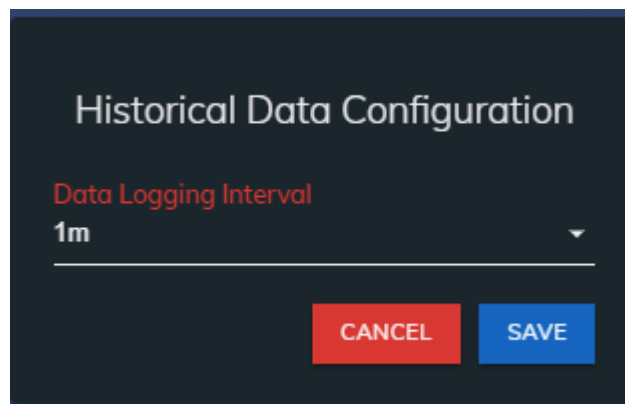

## 3.6 UPS Settings

The UPS Settings page can be accessed by clicking on UPS Settings in the menu. This page is divided into 5 tabs, which are described in this section.

### 3.6.1 Status Tab

This tab displays the current UPS measurements and alarms. The information on this tab will update approximately every 10 seconds.

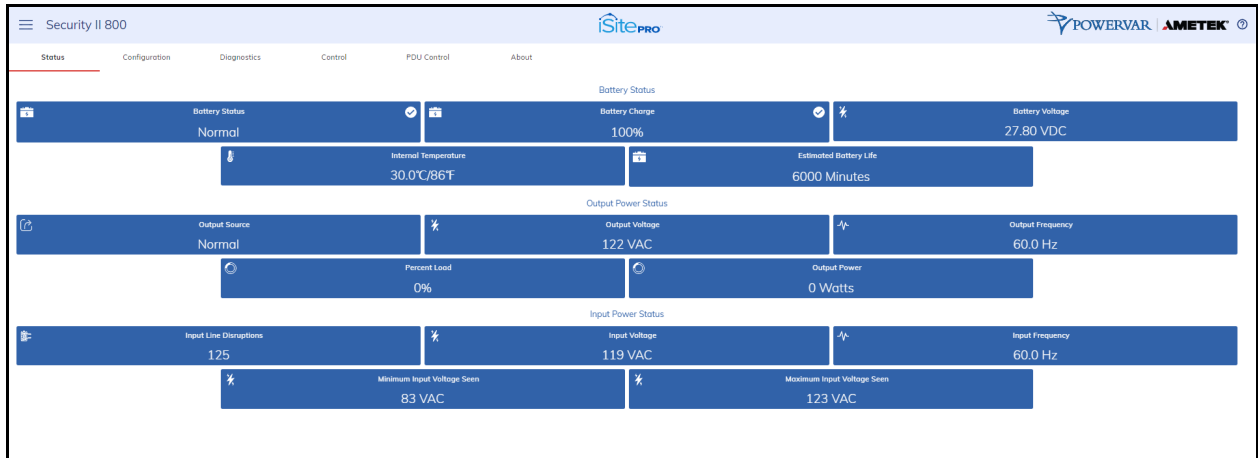

- **Battery Status:** States are Normal, Charging or Discharging. This value is returned as the object: upsBatteryStatus in the UPS MIB - RFC1628.
- **Battery Charge Remaining:** Current percentage of the remaining total battery charge. This value is returned as the object upsBatteryChargeRemaining in the UPS MIB - RFC1628.
- **Battery Voltage:** Voltage measured at the battery or charger output. This may be reported as "string" voltage or "cell" voltage depending on the UPS model. This value is returned as the upsBatteryVoltage object in the UPS MIB - RFC1628.
- **Internal Temperature:** The internal temperature reported by the UPS. This value is returned as the upsBatteryTemperature object in the UPS MIB - RFC1628.

- **Est. Battery Life:** Sometimes referred to as Estimated Autonomy. This is an estimate of the amount of time the UPS batteries can sustain the current load. This value is continuously recalculated based on the operating conditions of the UPS. When the UPS is on battery, this value may decrease faster than expected due to battery age and other variables that are difficult to model in the calculation algorithm. This value is returned as the object; upsBatteryEstimatedMinutesRemaining in the UPS MIB - RFC1628.
- **UPS Up Time:** The amount of time since the UPS was last started. (This value is returned as the sysUpTime object in MIB-2).
- **Output Voltage:** The measured UPS output voltage.
- **Output Source:** The source of the UPS output power. Under normal conditions this will be Utility. The source may also be reported as Battery or Bypass.
- **Percent Load:** The percentage of the UPS capacity currently being supplied by the UPS.
- **Output Watts:** The measured UPS output power in Watts.
- **ECO Mode:** Indicates if ECO Mode is currently active or not active. This will only appear on units with the ECO Mode feature.
- **Input Line Disruptions:** The number of times the UPS has been on inverter due to input voltage being out of tolerance.
- **Input Frequency:** The frequency measured on the UPS AC input.
- **Input Voltage:** The voltage measured at UPS AC input.
- **Min. Input Voltage Seen:** The lowest input voltage detected by the UPS since last reset. (See Also UPS Control to reset the stored minimum input voltage to the current input voltage).
- **Max. Input Voltage Seen:** The highest input voltage detected by the UPS since last reset. (See Also UPS Control to reset the stored maximum input voltage to the current input voltage)



### 3.6.2 Configuration Tab

This tab is used to configure various UPS settings.



NOTE: Your UPS may not support all the configuration options listed in this document.

- **Temperature Threshold:** The maximum internal UPS temperature allowed before triggering a UPS over temperature alarm.
- **Overload Threshold:** The maximum percent load allowed before triggering a UPS overload alarm.
- **Power Margin Threshold:** The maximum percent load allowed before triggering a Power Margin Exceeded Alarm.
- **Low/High Transfer Point:** The transfer points determine the range of acceptable output voltage values. If the input line voltage drops below the lower transfer point or rises above the upper transfer point, the UPS takes corrective action either by using the booster or switching to battery power. The proper setting of transfer points depends on the voltage tolerance of the devices connected to the UPS. Setting the transfer points closer together will cause the UPS to provide a more tightly controlled voltage but may also cause the UPS to switch to battery power more frequently, depending on the quality of your AC line power. The factory default values are sufficient for most applications.
- **Battery Replacement Date:** The date on which the UPS was first commissioned or when the battery was last replaced. This value will be set automatically the first time iSite PRO boots up and retrieves a valid date from a network time (NTP) server. The assumption is that the iSite PRO is installed at about the same time the UPS is first installed and commissioned. It is up to the user to set this date to a more accurate commissioning date and to maintain the date when batteries are replaced in the future.

- **Replace Battery When:** Counts elapsed time from the value in the Battery Replacement Date field. Low Battery Alarm Duration: Low Battery Alarm Duration: Triggers the UPS Low Battery alarm when estimated minutes remaining -- as computed by the UPS.
- **Low Battery Alarm Duration:** Triggers the UPS Low Battery alarm when estimated minutes remaining -- as computed by the UPS or limited by the Authorized Autonomy setting -- reaches this value.
- **Shutdown Type:** This setting controls the behavior of the UPS when a shutdown command is received from monitoring software. If "Whole UPS" is selected, the UPS output and internal electronics are turned off. In this state, the UPS will not be able to communicate with monitoring software until the UPS is restarted. If "Output Only" is selected, the UPS output is turned off, but the UPS internal electronics remain on.
- **Auto Restart:** This setting controls the conditions under which UPS output is restarted after the UPS has been shut down. If "AC Return" is selected, UPS output is automatically restarted when AC line power is restored. If "Manual Return" is selected, UPS output must be restarted manually, either by turning the UPS power switch off, and then on, or by issuing a command on the serial port of the UPS.
- **UPS Name:** The name of this UPS. (This value will be returned as upsIdentName object in the SNMP UPS MIB - RFC1628).
- **Attached Devices:** A description of the devices attached to the UPS. (This value will be returned as upsIdentAttachedDevices object in the SNMP UPS MIB - RFC1628).
- **Audible Alarm:** Controls audible alarms that the UPS may initiate during tests or alarm conditions. You can use this control to silence audible alarms that might sound when a UPS test is initiated. (The control is the upsConfigAudibleStatus object in SNMP UPS MIB - RFC1628).
- **Auto Stop:** Sets the AutoStop control in some UPS' that cause the UPS to turn off after some time with no measurable load present.

### 3.6.3 Diagnostics Tab

This tab is used to initiate a UPS Diagnostics test.

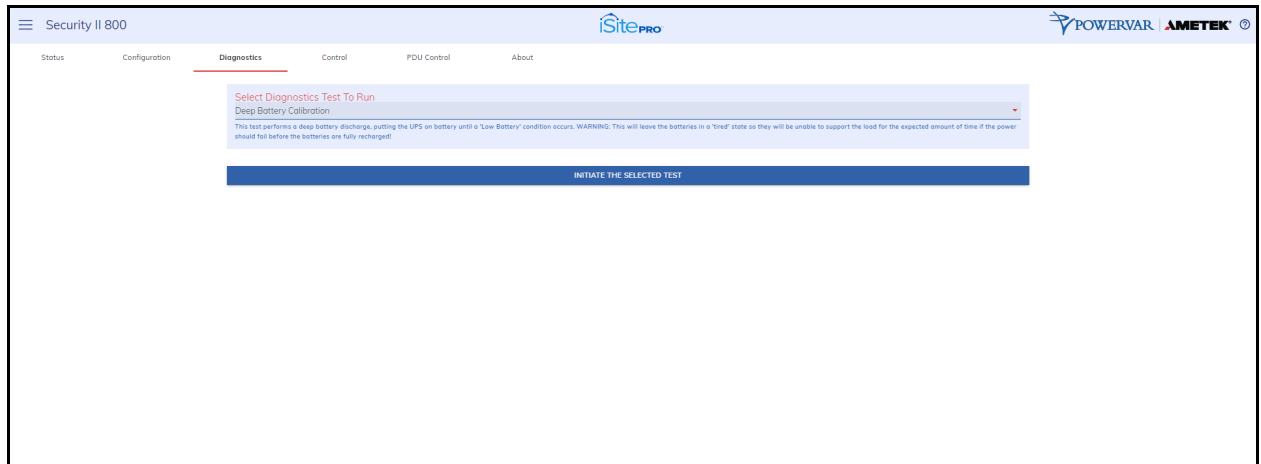

#### NOTE:

- Your UPS may not support all the test options listed in this section.
- Your UPS may need to recharge its batteries after a battery test is complete. Your UPS may refuse to initiate a battery test if the battery is recovering from a previous test or if some other condition exists that would invalidate the results.
- Select a test from the list box. To start the test, click the button: "Initiate Selected Test".

**Battery Run Test:** This test causes the UPS to run on battery power for a specified amount of time. After the specified amount of time, the UPS will switch back to AC line power.

**Quick Battery Test:** This test performs a qualitative analysis of the condition of the battery. This test runs at regular intervals. The impedance test returns one of three results; Passed, Battery is significantly degraded, or the battery is defective and must be replaced as soon as possible.

**Deep Battery Calibration:** This test performs a deep battery discharge, putting the UPS on battery until a "Low Battery" condition occurs.

**WARNING:** This will leave the batteries in a "tired" state so they will be unable to support the load for the expected amount of time if AC input power should fail before the batteries are fully recharged!

### 3.6.4 Control Tab

This tab is used to perform various UPS control functions.

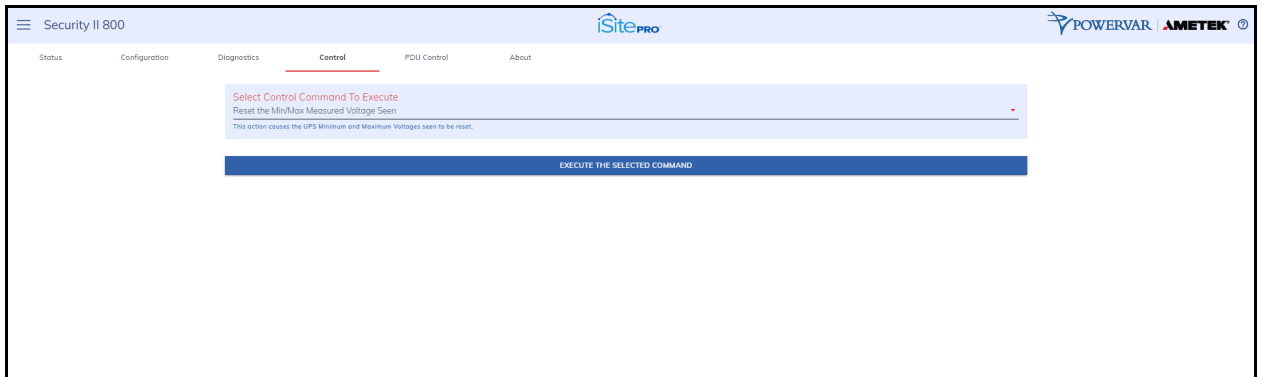

Select one of the control commands by selecting it from the list box. Click the "Execute the Selected Command" button to execute the command.

**NOTE:** Your UPS may not support all of the options listed here

- **Reset the Min/Max Measured Voltage Seen:** A record of the Minimum and Maximum input line voltages are stored in your UPS.
- **Mute the Audible Alarm:** This action mutes the audible alarm for the duration of the current event. It does not disable the alarm. If you want to silence the audible alarm for future events, navigate to the UPS Configuration menu. The control for the audible alarm is in the General Settings dialog area.
- **Turn UPS Output On:** This action causes the UPS output to immediately turn on.
- **Turn UPS Output Off:** This action causes the UPS output to immediately turn off.

**WARNING:** All loads connected to this UPS will be turned off.

- **Reboot the UPS:** This action causes the UPS output to immediately turn off and then restart after the time specified.

**WARNING:** When you initiate the reboot control, all loads connected to this UPS will lose power and will turn back on when the UPS output is re-energized. Make sure this is what you want to do before you initiate this control!

**NOTE:** This command is not active on 3-phase UPS.

### 3.6.5 PDU Control Tab

This tab can be used to control and configure the UPS's Programmable Outlets.

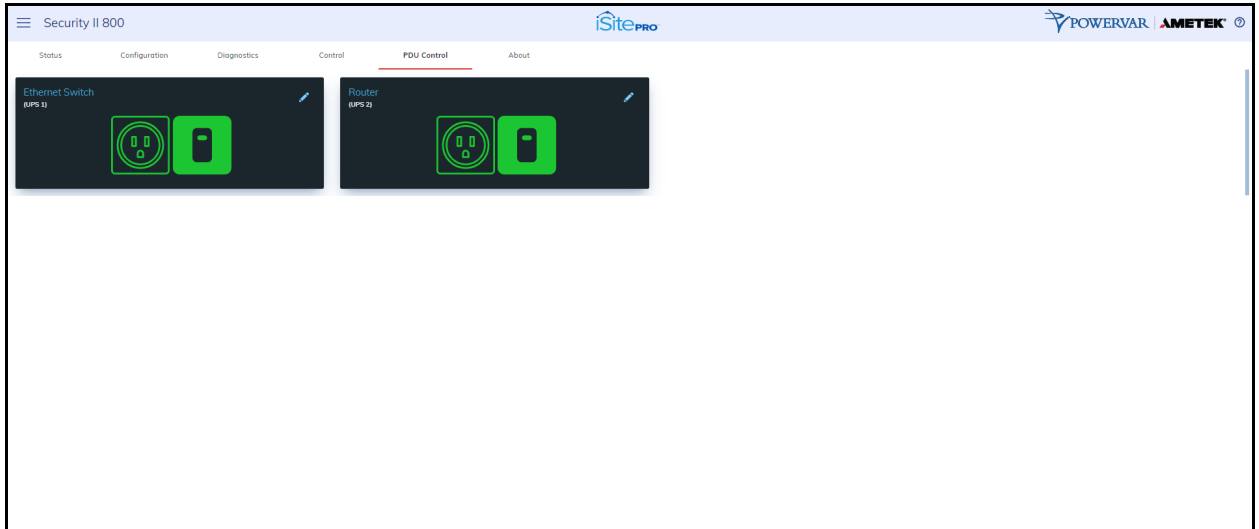

The current state of the outlet is indicated by the state of the switch graphic, and the graphic color. If the switch position is up, and the color is green, then the outlet is currently on. If the switch position is down, and the color is red, then the outlet is currently off.

Clicking on the switch will toggle the state of each outlet. You will be presented with a confirmation dialog before the action is taken.

**WARNING** When you turn off an outlet, all loads connected to that outlet will turn off.

### 3.6.6 PDU Configuration Screen

Access this screen by clicking on the edit icon on the PDU control screen.



The screenshot shows the 'PDU Control' configuration screen for a 'Security II 800' device. The interface includes a navigation menu with 'Status', 'Configuration', 'Diagnostics', 'Control', 'PDU Control', and 'About'. The 'PDU Control' section is active, displaying the following configuration fields:

- Socket Name:** Ethernet Switch
- URL:** (Empty)
- Shut Off When On Battery And Pct is Below:** 5
- Shut Off When On Battery For:** 999
- Turn On After:** 0

At the bottom right, there are 'CANCEL' and 'UPDATE' buttons.

- **Socket Name:** A descriptive name of the device(s) connected to the outlet.
- **URL:** The URL of the device connected to the outlet.
- **Shut Off When On Battery And Pct is Below:** The percent battery at which to turn this outlet off when the UPS is running on battery.
- **Shut Off When On Battery For:** The amount of time after the UPS starts running on battery power, to turn this outlet off.
- **Turn On After:** The amount of time to wait to turn this outlet back on following a power outage.

### 3.6.7 About Tab

This tab displays the identity and nominal ratings of the UPS.

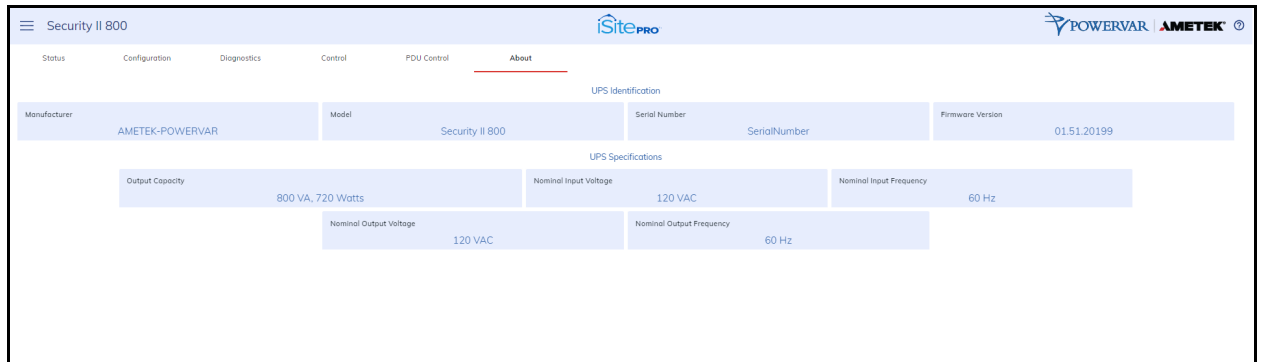

- **Model:** The model number of the UPS unit.
- **Serial Number:** The serial number of the UPS unit.
- **Firmware Version:** The version number of the firmware in the UPS.
- **Capacity:** The maximum power output of the UPS. Capacity is measured in VA and Watts. The VA measurement is the maximum power available to drive devices with switched-mode power supplies such as computers. The Watts measurement is the maximum power available to drive resistive loads such as lighting or devices with motors.
- **Nominal Input Voltage:** The line voltage that the UPS is designed to operate with.
- **Nominal Input Frequency:** The line frequency that the UPS is designed to operate with.
- **Nominal Output Voltage:** The nominal output voltage supplied by the UPS.
- **Nominal Output Frequency:** The nominal frequency that supplied by the UPS.

### 3.7 Network Screen

This screen enables the user to configure the network settings of the iSite PRO.

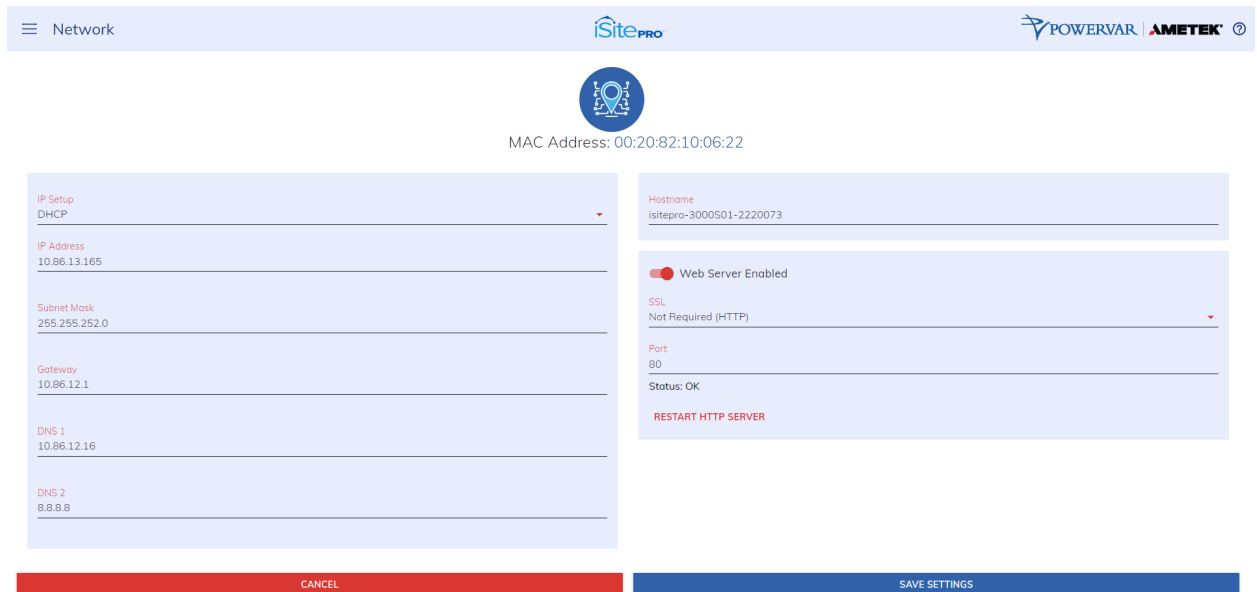

- **IP Setup:** Specifies if the device will have a static IP Address, or will dynamically be assigned network settings through DHCP.
- **IP Address:** Current IP Address of the network interface on the RJ45 Ethernet port.
- **Subnet Mask:** Current Subnet Mask of the network interface on the RJ45 Ethernet port.
- **Gateway:** Current Gateway of the network interface on the RJ45 Ethernet port.
- **DNS 1:** Current configured primary DNS of the network interface on the RJ45 Ethernet port.
- **DNS 2:** Currently configured secondary DNS of the network interface on the RJ45 Ethernet port.
- **Hostname:** A configurable unique name to be used to access the device instead of an IP Address.
- **SSL:** Specifies whether the web server will be SSL encrypted (HTTPS) or not (HTTP). The default certificate is self-signed and will require the user continue through a safety notification if a custom signed certificate is not uploaded to the device.



- **Web Server Enabled:** Specifies if the web server is enabled or disabled.
  - *NOTE:* If disabling the web server, the web interface and REST API will be disabled, only limited functionality over SNMP will remain if enabled.
- **Port:** Port number to use for the web server.
- **Status:** This will provide the status of the server. If using HTTPS, this will provide information regarding which SSL Key/Certificate is being used. If the key/certificate files were uploaded by the user, it will indicate if they are valid. If they are not valid, the default key/certificate will be used.

Use the “RESTART HTTP(S) SERVER” Button to restart the server if new key/certificate files have been uploaded using the Utilities Screen. This will cause the current page to reload.

- The Cancel button will reset all fields to their initial value.

## 3.8 Network Advanced Screen

This screen enables the user to configure the network settings of the iSite PRO.

### 3.8.1 Date/Time Settings Tab

This tab allows the configuration of the date and time of the iSite PRO.

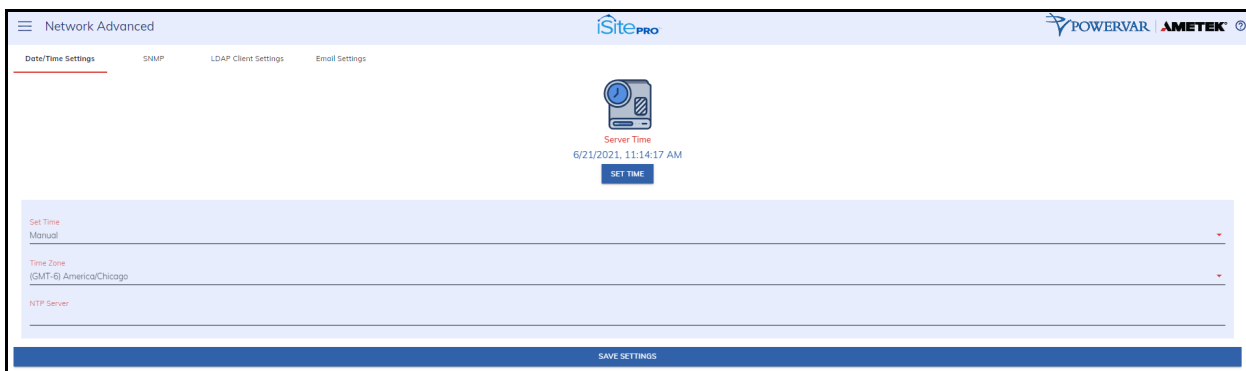

- **Server Time:** Displays the device’s internal time based on the configured time zone.
- **Set Time:** Specifies the method for setting the time in the iSite PRO. Options for this setting are NTP or manual. NTP will use the NTP Server option to automatically sync the device time every day.
- **Time Zone:** Specifies the desired time zone adjustment for the Squid device.

- **NTP Server:** Specifies the hostname or IP address of the NTP server to use for time synchronization.

### 3.8.2 SNMP Tab

This tab allows the configuration of the SNMP functionality of the iSite PRO.



The SNMP agent in the iSite PRO conforms to the SNMP UPS MIB (RFC1628). This MIB was originally circulated in SNMPv2 syntax. An SNMP v1 translation of RFC1628 MIB file is available from [Powervar Connectivity Website Page](#).

#### SNMP V1 Communities

*SNMP V1 Communities* is an authentication scheme that enables an intelligent network device to validate SNMP requests.

**Name:** The name of an SNMP access community (i.e. "public" or "private").

NOTE: Blank spaces are not accepted within the name string.

**Source:** The IP address/mask of allowed stations.

A subnet range can be specified using the IP/MASK or IP/BITS syntax as shown below. This can be specified as IP/MASK or IP/BITS.

10.5.2.0/[bit mask integer] = allow all address in the specific range that passes through the mask.

Examples:

10.5.2.0/8 = 10.0.0.1 thru 10.255.255.254

10.5.2.0/16 = 10.5.0.1 thru 10.5.255.254

10.5.2.0/20 = 10.5.0.1 thru 10.5.15.254

10.5.2.0/24 = 10.5.2.1 thru 10.5.2.254

10.5.2.0/26 = 10.5.2.1 thru 10.5.2.62

10.5.2.0/32 = same as no mask, 10.5.2.0

**Access:** Enable Read Only or Read/Write access for individual communities

### **SNMP V3 Users**

In contrast to SNMP version 1 (SNMPv1) and SNMP version 2 (SNMPv2), SNMP version 3 (SNMPv3) supports authentication and encryption.

SNMPv3 uses the user-based security model (USM) for message security and encryption.

**Username:** The name of an SNMPv3 user.

**Authorization:** Choice of MD5 or SHA authorization.

**Encryption:** Choice of AES or DES encryption.

**Passphrase:** The Passphrase used for authentication and encryption.

**Access:** Choose Read Only or Read Write access for each user.

### **Trap Receivers**

**Community:** The community (authentication string) of the SNMP trap receiver community

**Destination Address:** The IP address of the trap receiver.

**Port:** The port used by the trap receiver. Typically, this is 162.

### **Traps Sent**

**Send Authentication Traps:** Enables or disables the agent to send SNMP authentication traps.

### **About UPS Traps**

There are four traps defined in the standard UPS MIB (RFC1628):

#### **Trap1:** upsTrapOnBattery

DESCRIPTION: "The UPS is operating on battery power. This trap is persistent and is resent at one-minute intervals until the UPS either turns off or is no longer running on battery."

#### **Trap2:** upsTrapTestCompleted NOTIFICATION-TYPE

DESCRIPTION: "This trap is sent upon completion of a UPS diagnostic test."

#### **Trap3:** upsTrapAlarmEntryAdded NOTIFICATION-TYPE

DESCRIPTION: "This trap is sent each time an alarm is inserted into the alarm table. It is sent on the insertion of all alarms except for upsAlarmOnBattery and upsAlarmTestInProgress covered in Traps 1 and 2."

#### **Trap4:** upsTrapAlarmEntryRemoved NOTIFICATION-TYPE

DESCRIPTION: "This trap is sent each time an alarm is removed from the alarm table. It is sent on the removal of all alarms except for upsAlarmTestInProgress."

### **WELL KNOWN ALARMS: (1-24)**

Content sent in Traps 3 and 4 include a numeric identity (upsAlarmId) of the specific alarm that has been added or removed from the table. The MIB defines 24 specific upsWellKnownAlarms.

Value=1.3.6.1.2.1.33.1.6.3.x

Where; x is the alarm identification number of the specific alarm entry.

### **ADDITIONAL ALARMS: (25-31)**

In addition to the 24 wellKnownAlarms defined in RFC1628, the adapter will also send additional alarms not defined in the MIB.

### 3.8.3 LDAP Client Settings

This form is used to configure the settings used by the LDAP client to authenticate with an LDAP server.

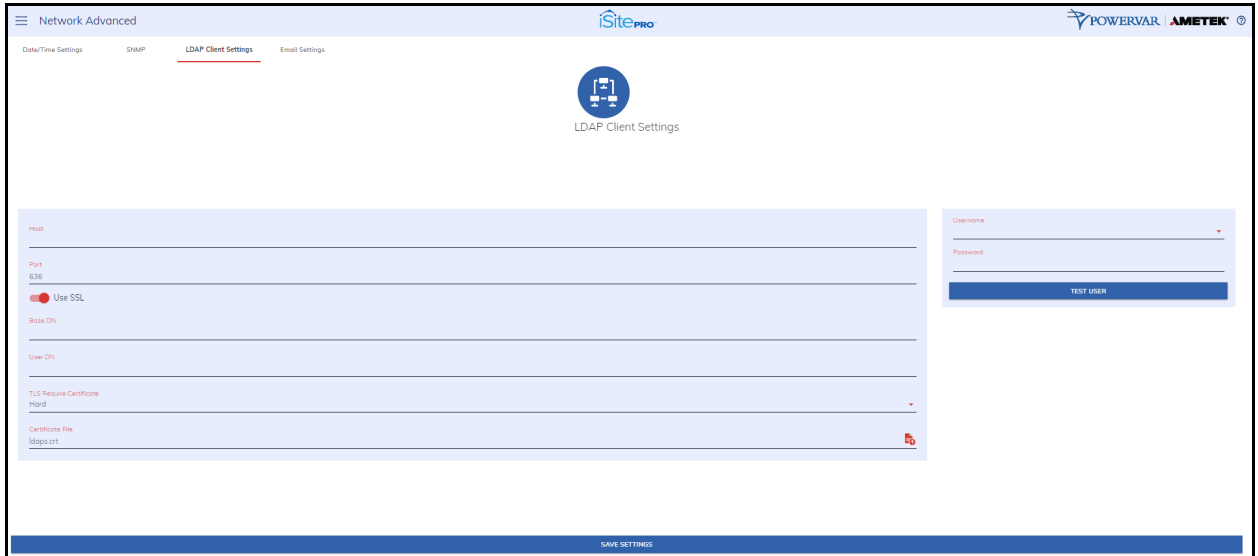

The screenshot shows the 'LDAP Client Settings' page in the SitePRO interface. The page has a navigation bar with 'Network Advanced', 'SitePRO', and 'POWERVER / AMETEK' logos. Below the navigation bar, there are tabs for 'Date/Time Settings', 'SNMP', 'LDAP Client Settings', and 'Email Settings'. The 'LDAP Client Settings' tab is active. The main content area contains a form with the following fields and options:

- Host:** A text input field.
- Port:** A text input field with '636' entered.
- Use SSL:** A radio button that is selected.
- Base DN:** A text input field.
- User DN:** A text input field.
- TLS Require Certificate:** A dropdown menu with 'Hard' selected.
- Certificate File:** A text input field with 'ldaps.crt' entered and a file upload icon.

On the right side of the form, there is a section for authentication:

- Username:** A text input field.
- Password:** A text input field.
- TEST USER:** A blue button.

At the bottom of the page, there is a 'SAVE SETTINGS' button.

The following information can be configured on this page:

- **Host:** The IP address or name of the LDAP server
- **Port:** The listening port used by the LDAP server, for non-secure connections this is usually 389, for secure connections this is usually 636. If using a secure connection, then check the **LDAPS** option.
- **Base DN:** This is the base DN of the server. (i.e. dc=AMETEK,dc=com)
- **User DN:** The User DN used to bind to the LDAP server and authenticate the user. (i.e. uid=%UserName,dc=AMETEK,dc=com)
- *There are 2 macros available when authenticating to the LDAP server. They are:*
  - **%UserName%** - This will be replaced by the username when authenticating to the LDAP server.
  - **%FullName%** - This will be replaced by the user's name when authenticating to the LDAP server.

- **TLS Require Certificate:** This is optional, based on the LDAP server requirements. The options are Never, Hard, Demand, Allow and Try.
- **Certificate File:** This is optional based on the LDAP server requirements. Upload the certificate file to the iSite PRO.**LDAP Client.**
- The LDAP Client page can be accessed by clicking on LDAP Client Settings in the menu. This page contains 2 forms which can be used to configure and test the LDAP client settings and functionality.
- **Test LDAP Client**  
Use this form to test your LDAP client configuration. Select a user from the list and enter the LDAP passcode for this user and press the Perform Test button.

### 3.8.4 Email Settings

The Email Settings page can be accessed by clicking on Email Settings tab of the Advanced Networking page.



#### Secure SMTP Settings

The following settings can be configured for send email using Gmail, Office 365 or any other secure or non-secure SMTP server.

**Email Server:** Select the type of email server to use. The options are Gmail, Office 365 or other. The Gmail and Office 365 options should be used if you are using the Secure SMTP service provided by one of these services. Select Other if you are using your own SMTP server or another service.

**Host:** The host name or IP address of the SMTP server

**Port:** The port number used by the SMTP server. Typical SMTP Port numbers are listed below.

Port Number	Description
25	Standard non-secure port
465	Deprecated port for secure SMTP
587	Modern port used for secure SMTP
2525	Alternative, non-standard SMTP port

- **Username:** The username used for authentication on the SMTP server
- **Password:** The password used for authentication on the SMTP server.
- **Mail From:** The mail from address used on outgoing email messages.  
**NOTE:** This is ignored when using Internet services such as Gmail, in this case the From address is the primary email address for the user.
- **SSL/TLS Options:** Enable *Use SSL* and/or *Use Start TLS* toggle switches to enable the appropriate secure protocol to use.
- **Authentication Method** – Select between PLAIN or CRAM-MD5 authentication methods, or None.
- **Contacts**
  - This allows for a list of email recipients, other than users to receive email messages based on alarm severity.
- **Send a Test Email**
  - Use this to test your configuration. A valid email address must be supplied.
- **Using Gmail**
  - When Gmail is selected as the Email Server, you will only need to configure the Username, Password and Mail From options as seen below. It will automatically be configured to use smtp.gmail.com on port 587 using SSL and Start TLS options.

The screenshot displays the 'Email Settings' configuration page in the 'Network Advanced' interface. The page includes the following elements:

- Navigation:** 'Data/Time Settings', 'SNMP', 'LDAP Client Settings', and 'Email Settings' (active).
- Section Header:** 'Email Settings' with a corresponding icon.
- Form Fields:**
  - Email Server:** A dropdown menu currently set to 'Gmail'.
  - Username:** A text input field containing 'user@gmail.com'.
  - Password:** A text input field with masked characters '\*\*\*\*\*'.
  - Mail From:** A text input field containing 'user@gmail.com'.
- Contacts Section:** A section titled 'Contacts' showing 'No Contacts' with an 'ADD CONTACT' button.
- Footer:** A 'SAVE SETTINGS' button.



The Secure SMTP option is disabled by default by Google. To enable this option, you must go to the Security Section of your Google Account and Allow less secure apps to access your account.

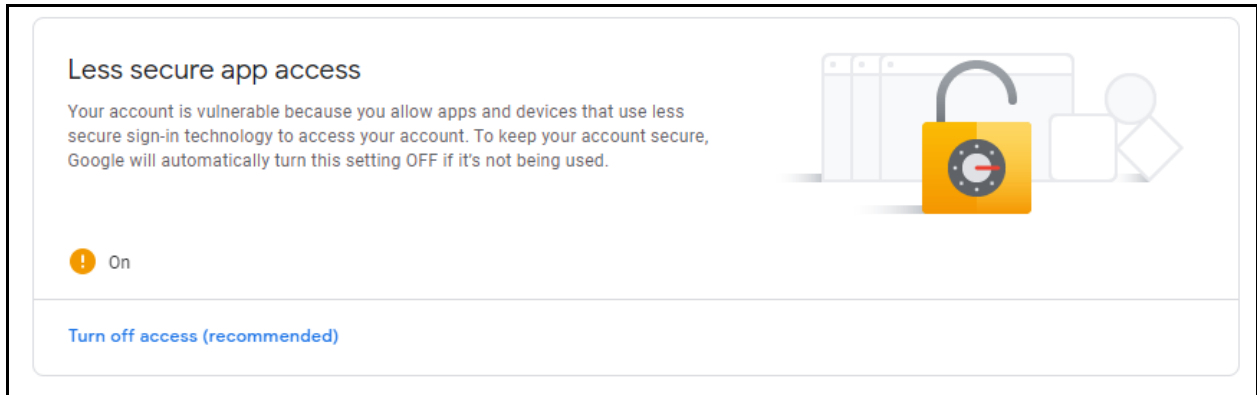

- **Using Office 365**

When Office 365 is selected as the Email Server, you will only need to configure the Username, Password and Mail From options as seen below. It will automatically be configured to use smtp.office365.com on port 587 using SSL and Start TLS options.

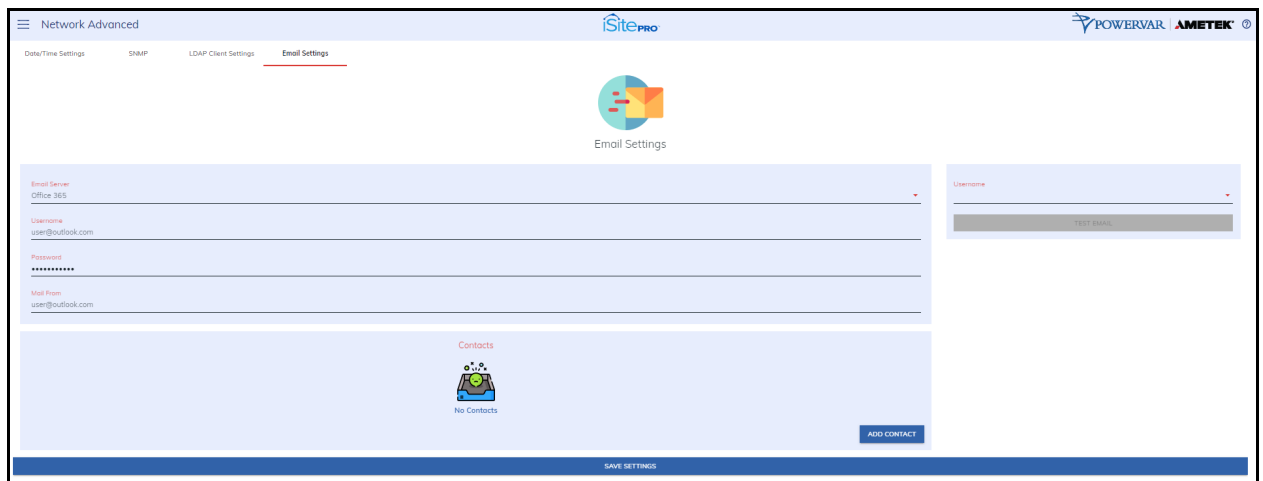

The Secure SMTP option is disabled by default by Microsoft.

### 3.9 Users Screen

The Users screen contains the list of currently configured users and their permissions. Using the Add New User push button New users can be added using this page.

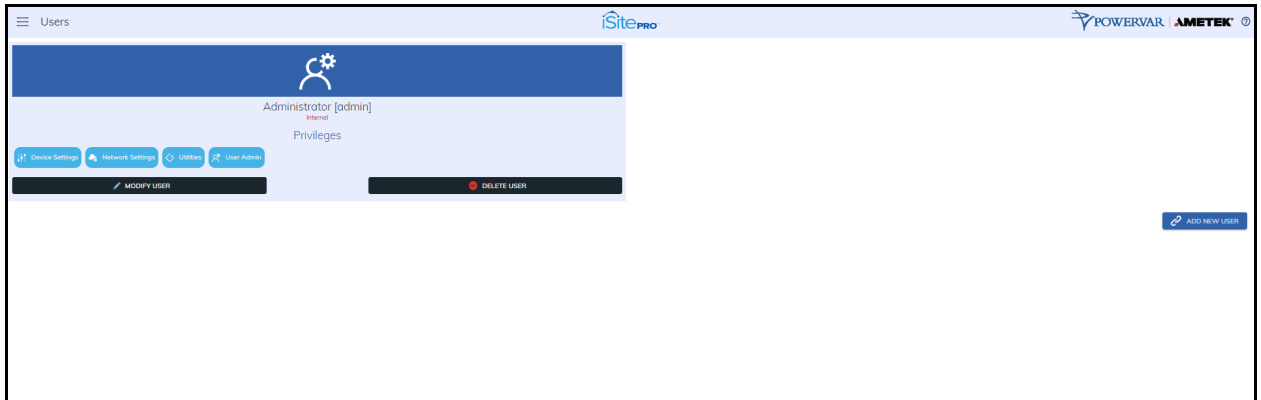

### 3.9.1 Edit/Add User Account

Use this screen to edit or delete a user. If the user is configured to use an “Internal” authentication mode, then the iSite PRO performs the authentication using the passcode, which is stored locally to the iSite PRO. If the authentication mode is LDAP, then the iSite PRO will use the LDAP settings configured on the LDAP Client Settings page to authenticate the user. In this case the passcode of the user is not stored in the iSite PRO.

The Notifications section allows for configuration of email notifications.

- **Email Message Type:** Select the type of Email message to receive. The options are:
  - **Html** – The email body will be formatted as HTML
  - **Long** – The mail body will be formatted as Text and contain detailed information about the device in the email body.
  - **Short** – Same as Long but will not contain detailed information about the device in the email body.
  - **Short with no Subject** – same as Short but with no subject.
- **Notify on...:** Select which type of alarms to be notified on, Informational, Warning or Severe.



## Privileges

The following access flags are used to control user permissions:

- **UPS Settings:** This access flag is required for the user to access the UPS Settings screen.
- **Network Settings:** This access flag is required for the user to access the Network and Network Advanced screens.
- **Utilities:** This access flag is required for the user to access the Utilities screen.
- **User Admin:** This access flag is required for the user to access the Users screen.

## 3.10 Utilities

The Utilities allows the user to execute various tasks that backs-up, configures, restores, reboots, and updates the iSite PRO.

### 3.10.1 File Upload Tab

This tab enables the user to upload various updates and configurations of the iSite PRO:

- **Firmware Update**  
(Firmware Image File) Use this file to update the firmware of the iSite PRO.
- **Configuration File**  
(CFG File) Use this file to update the configuration of the iSite PRO.
- **SNMP Configuration**  
(CONF File) Use this file to update the Simple Network Management Protocol configuration of the iSite PRO.
- **HTTPS SSL Certificate.**  
(Security Certificate) Use this file to update the SSL Security Certificate of the iSite PRO. This file must in pem format.  

```
-----BEGIN CERTIFICATE-----  
<content>  
-----END CERTIFICATE-----
```
- **HTTPS SSL Certificate Key**

(KEY File) Use this file to update the Certificate Private Key of the iSite PRO. This file must be in pem format.

```
-----BEGIN RSA PRIVATE KEY-----
```

```
<content>
```

```
-----END RSA PRIVATE KEY-----
```

- **HTTPS SSL Certificate Authorization**

(CA File) Use this file to update the Certificate Authorization of the iSite PRO. This file must be in pem format.

```
-----BEGIN CERTIFICATE-----
```

```
<content>
```

```
-----END CERTIFICATE-----
```

### **3.10.2 Backup/Restore Tab**

This tab gives an opportunity to backup (snapshot) of the current settings and users of the iSite PRO. Additionally, the created backup file can be restored.

### **3.10.3 Factory Reset Tab**

This tab provides a factory reset to restore the iSite PRO to its original factory settings.

### **3.10.4 Reboot Device Tab**

This tab provides a reboot to the iSite PRO.

### 3.11 Modbus Server

The iSite PRO runs a Modbus/IP Server as well as a Modbus/RTU server over RS485 (half-duplex) on the auxiliary RJ45 port. This feature is only available on certain models of the iSite PRO.

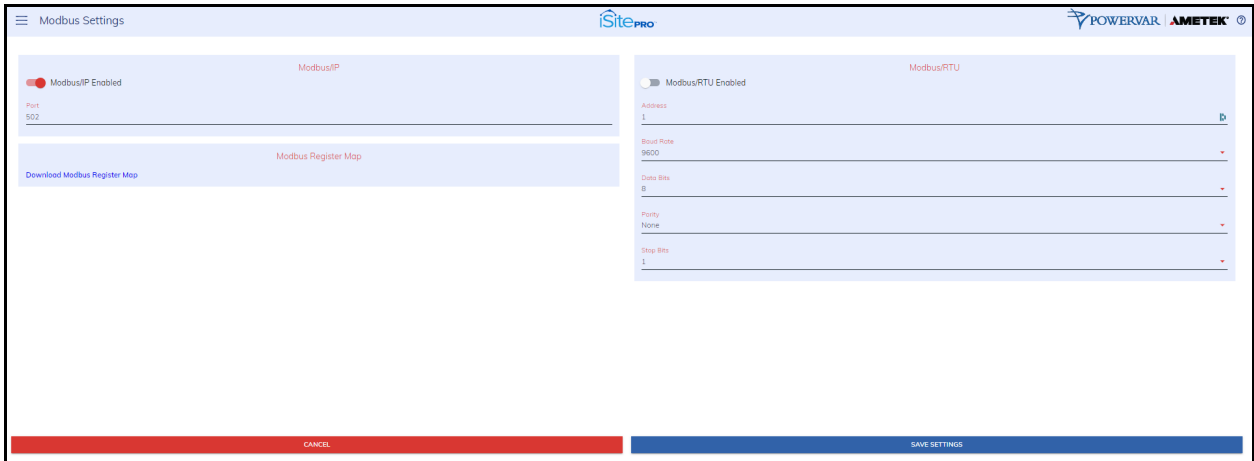

#### 3.11.1 Modbus/RTU Wiring

The pinout for the BlueBus/Modbus RJ45 connector is as follows:

Pin No.	Blue Bus	RS485
1	HI	-
2	LO	-
3	-	D+
4	VDD	-
5	GND	GND
6	-	D-
7	VDD	-
8	GND	GND

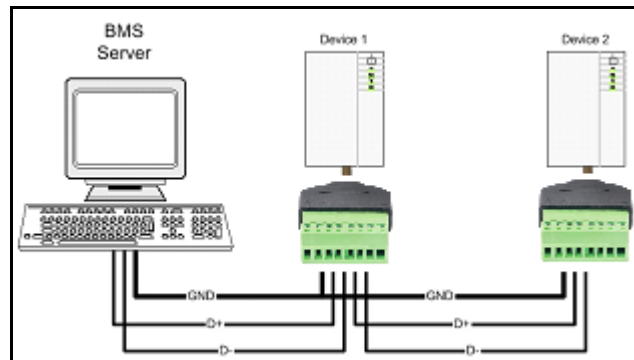

Half Duplex Wiring Diagram

### 3.11.2 Modbus/IP Server Settings

- **Modbus/IP Enabled:** Enable/Disable the Modbus/IP Server
- **Port:** The port the server listens on, this is typically 502.

### 3.11.3 Modbus/RTU Server Settings

- **Modbus/RTU Enabled:** Enable/Disable the Modbus RTU Server
- **Address:** The address of this device on Modbus.
- **Baud Rate:** The baud rate used by the RS422/485 interface.
- **Parity:** The parity used by the RS422/485 interface.
- **Data Bits:** The data bits used by the RS422/485 interface.
- **Stop Bits:** The stop bits used by the RS422/485 interface.

### 3.11.4 Modbus Register Map

The MODBUS Register MAP includes identity, measures, and status information obtained from the UPS by the iSite PRO. This register map is downloadable from the iSite PRO web interface.

### 3.12 Environment Sensors

#### 3.12.1 Environment Sensor Kit Components

In addition to the iSite PRO, the following components are provided in the Environment Sensor Kit.

Environment Sensor	
Adhesive Backed Velcro Strip	
Blue Bus Cable 3m (~15m)	

### 3.12.2 Environment Hardware Specifications

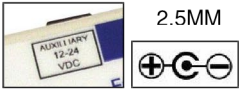
Environment Sensor	<b>Input power</b>	<p>Single sensor powered from Blue Bus @ 7-24Vdc, &lt; 0.36 watts</p> <p>Multiple sensors may require an auxiliary power supply. (Refer to Appendix C: <i>Compatibility Table for ManageUPS Blue Bus Accessories</i>)</p> <p>Auxiliary power input accepts 12-24Vdc unregulated. Connector is 2.5mm center pin. Outer barrel is positive, inner post is negative.</p> 
	<b>Temperature</b>	<p>Measurement range 0 – 75 degC Accuracy +/- 1 degC between 10 and 50 degC</p>
	<b>Relative Humidity</b>	<p>Measurement range 1-99% RH Accuracy +/- 2% between 10 and 90 %RH</p>
	<b>Input Contacts</b>	<p>Accepts input from up to three (3) Form C dry contacts</p>
	<b>Output Relay</b>	<p>1 relay contact, rated 1A @ 30V (normally open or normally closed)</p>
	<b>Conformance</b>	<p><b>Emissions:</b> EMC Directive 89/336/EEC as amended by 92/31/EEC and 93/68/EEC EN 55022: 19948+ A1:2000 + A2:2003 EN 50091-2: 1995 EN 61000-3-2:2000 EN 61000-3-3:1995 +A1:2001</p> <p><b>Immunity:</b> EMC Directive 89/336/EEC as amended by 92/31/EEC and 93/68/EEC EN 55022: 19948+ A1:2000 + A2:2003 EN 50091-2: 1995</p> <p>EN 61000-4-2:1995 +A1:1998 + A2:2002 (IEC 1000-4-2) EN 61000-4-3:2002 (IEC 10000-4-3)</p> <p>EN 61000-4-4:1995 +A1:2001 + A2:2001 (IEC 1000-4-4) EN 61000-4-5:1995 +A1:2001 (IEC 1000-4-5) EN 61000-4-6:1996 +A1:2001 (IEC 1000-4-6) EN 61000-4-8:1993 +A1:2001 (IEC 1000-4-8) EN 61000-4-11:1994 +A1:2001 (IEC 1000-4-11)</p>
Blue Bus	<b>Cable</b>	<p>CAT5 STP with RF filter at ManageUPS connection point. (filtered cable not required for connections between sensors).</p>



### 3.12.3 Hardware Installation

#### Single Sensor

1. Install the iSite PRO in your UPS
2. Choose a location to mount the sensor within 3m (15') of you UPS.
3. Use the adhesive backed Velcro Strip to attach the Sensor to the mounting location.
4. Connect the Blue Bus cable between the Blue Bus port of the iSite PRO and a Blue Bus port on the sensor. (Connect the filtered end of the cable to the iSite PRO).

#### Multiple Sensors

1. Install the first sensor as described above – making sure to connect the Blue Bus cable from the iSite PRO to the IN port on the first sensor.
2. Connect a Cat5 STP cable between the Blue Bus OUT port on the first sensor and IN port on the second sensor.
3. Set the Terminator (switch #1) on the first sensor in the DOWN position. Set the terminator in the last sensor in the UP position.
4. Set the address (switches #2 - #5) of each additional sensor to be unique – different from the 1<sup>st</sup> sensor and different from any other sensor on the bus.

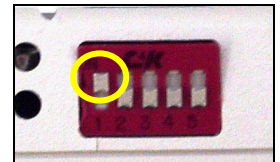
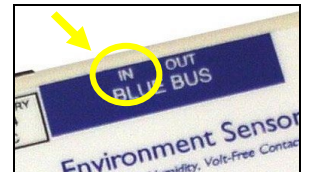

Address Translation Table	
32 = 0000	40 = 1000
33 = 0001	41 = 1001
34 = 0010	42 = 1010
35 = 0011	43 = 1011
36 = 0100	44 = 1100
37 = 0101	45 = 1101
38 = 0110	46 = 1110
39 = 0111	47 = 1111

<p>Address combination (switches #2-5) in the "all down" position is 0000.</p> <p>This combination will set the value "32" as the "address" in the ENVIRONMENT SENSOR.MIB.</p>	
--	---

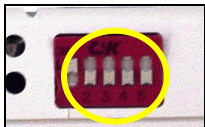
<p><b>NOTE for Multiple Sensors:</b></p> <p>There is a logical limit of 16 addresses available on the BLUE BUS.</p> <p>However, the number of sensors that can be added to the bus without adding supplemental power is limited by the power available in the UPS communications accessory slot.</p> <p>If you need more sensors than your UPS can power, add supplemental power to any sensor on the bus. Supplemental power will drive that sensor and any sensors downstream from the sensor connected to auxiliary power.</p>	
---	--

### 3.12.4 Environment Sensor View



This page will display the status of all Environment Sensors currently connected to the Blue Bus connector on the iSite PRO.

#### Environment Measurements

- Temperature:** Current temperature reading in Celsius and Fahrenheit.  
 (This value is returned as the temperature object in the Environment Sensor MIB)
- Relative Humidity:** Current relative humidity reading in percent.  
 (This value is returned as the humidity object in the Environment Sensor MIB).

#### Input Device Status

- Input Device (1-3) Name:** The user configurable name of the Input Device.  
 (This value is returned as the inputName1, inputName2, inputName3 objects in the Environment Sensor MIB)
- Input Device (1-3) Status:** The current status and severity level of the Input Device. The severity and the normal state of the input device can be configured on the Environment Sensor Configuration page.  
 (This value is returned as the inputStatus1, inputStatus2, inputStatus3 object in the Environment Sensor MIB)

### Output Relay Status

- **Output Relay Name:** The name of the Output Relay.  
(This value is returned as the outputName objects in the Environment Sensor MIB)
- **Output Relay Status:** The current state and severity level of the Output Relay. The conditions which can cause the output relay to energize can be configured on the Environment Sensor Configuration page.  
(This value is returned as the outputState object in the Environment Sensor MIB)

### 3.12.5 Environment Sensor Configuration



#### Identity Settings

- **Sensor Name:** A name given to the sensor.  
(This value is the name object in the Environment Sensor MIB)

#### Temperature Settings

- **Low Limit:** The temperature at which the low temperature condition is generated for this sensor.  
(This value is the tempLoThreshold object in the Environment Sensor MIB)
- **Low Alarm Severity:** The event severity level when temperature is below the low limit. If disabled, then no event is generated.
- **High Limit:** The temperature at which the high temperature condition is generated for this sensor.  
(This value is the tempHiThreshold object in the Environment Sensor MIB)
- **High Alarm Severity:** The event severity level when temperature is above the high limit. If disabled, then no event is generated.

### Relative Humidity Settings

- **Low Limit:** The relative humidity at which the low relative humidity condition is generated for this sensor.  
(This value is the humidityLoThreshold object in the Environment Sensor MIB)
- **Low Alarm Severity:** The event severity level when relative humidity is below the low limit. If disabled, then no event is generated.
- **High Limit:** The relative humidity at which the high relative humidity condition is generated for this sensor.  
(This value is the humidityHiThreshold object in the Environment Sensor MIB)
- **High Alarm Severity:** The event severity level when relative humidity is above the high limit. If disabled, then no event is generated.

### 3.12.6 Environment Sensor Inputs



The screenshot displays the 'Environment Sensor' configuration interface in iSitePRO. It features three 'Input Settings' sections for Input 1, Input 2, and Input 3. Each section contains the following fields:

- Name:** Input Device 1, Input Device 2, and Input Device 3.
- Normal State:** Open (with a dropdown arrow).
- Alarm Severity:** Disabled (with a dropdown arrow).
- Link:** (with a dropdown arrow).

At the bottom of the configuration area, there are two buttons: a red 'CANCEL' button and a blue 'SAVE SETTINGS' button.

- Name (1-3):** A user configurable name given to the input device.  
(These values are the inputName1, inputName2, inputName3 objects in the Environment Sensor MIB)
- Normal State (1-3):** The normal state of the input contact. When the input contact is not in this state the input fault condition is generated.  
(These values are the inputNormalState1, inputNormalState2, inputNormalState3 objects in the Environment Sensor MIB)
- URL (1-3):** A url associated with this device. Must be in the format 'http://hostname'. When this value is set the input name becomes a link on the environment status page.  
(These values are the inputUrl1, inputUrl2, inputUrl3 objects in the Environment Sensor MIB)
- Alarm Severity (1-3):** This setting determines the severity level of a fault condition on the input. If this setting is Disabled, then no condition will be generated, and the status will always be Normal.  
(These values are the inputFaultSeverity1, inputFaultSeverity2, inputFaultSeverity3 objects in the Environment Sensor MIB)

### 3.12.7 Environment Sensor Output



- Name:** A name given to the output relay. This is usually related to the device being controlled by the relay.  
 (These values are the outputName objects in the Environment Sensor MIB)
- Link:** A url associated with this device. Must be in the format 'http://hostname'. When this value is set the output name becomes a link on the environment status page.  
 (These values are the outputUrl objects in the Environment Sensor MIB)

### 3.12.8 Environment Sensor Triggers

Triggers are used to configure the relay to energize when any or all of the selected conditions are present. If no conditions are selected the output relay is disabled.

## 3.13 System Info

The System Info screen provides hardware information about the UPS and the number of users connected to the UPS via the iSite PRO.

## 3.14 User Profile

The User Profile screen provides the current user's information. The user can change their password and modify the email notifications.

## 3.15 Logout

The Logout option will log out the current user from the iSite PRO UI.

## 4.0 Recovery

The iSite PRO can be recovered from an inoperable state by using the USB port.

### 4.1 USB Setup/Login

- a. Using an USB-A to Micro-USB B cable, connect the iSite PRO to a Laptop/PC
- b. Using a web browser go to <https://169.254.10.100> to access the USB Login Screen

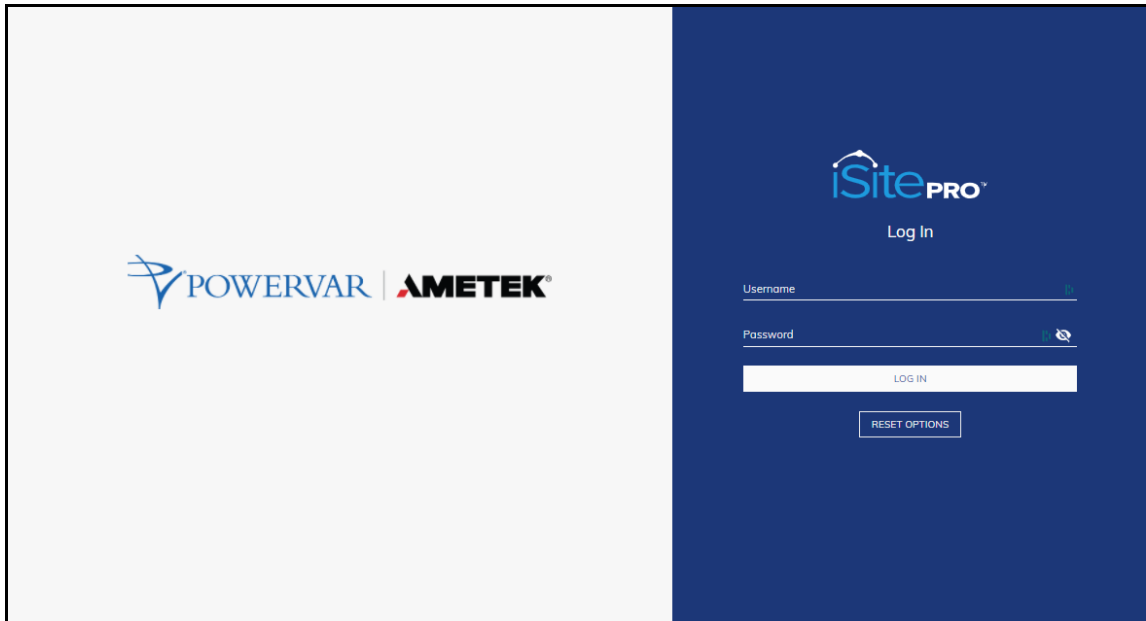

- c. Enter the credentials for an existing user.
- d. Click “LOG IN” pushbutton
- e. The user will now have full access to the UI according to their privileges.

### 4.2 Administrator Credentials

#### 4.2.1 Username and Password

The default username is admin, and the default password is Adm1nXXXXXX, where XXXXXX are the last six characters of the MAC address.



### 4.2.2 Finding MAC Address of the iSite PRO

Reference the sticker on the iSite PRO.

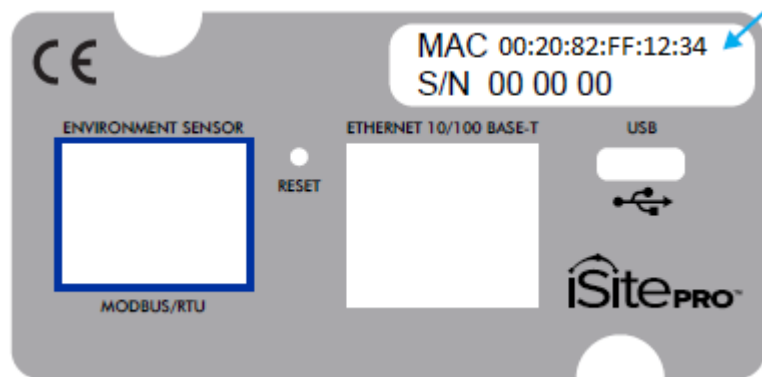

### 4.3 Reset Options

Without using credentials, the user can click the “RESET OPTIONS” pushbutton to restore the iSite PRO to a specific state:

**Reset Options Menu:**

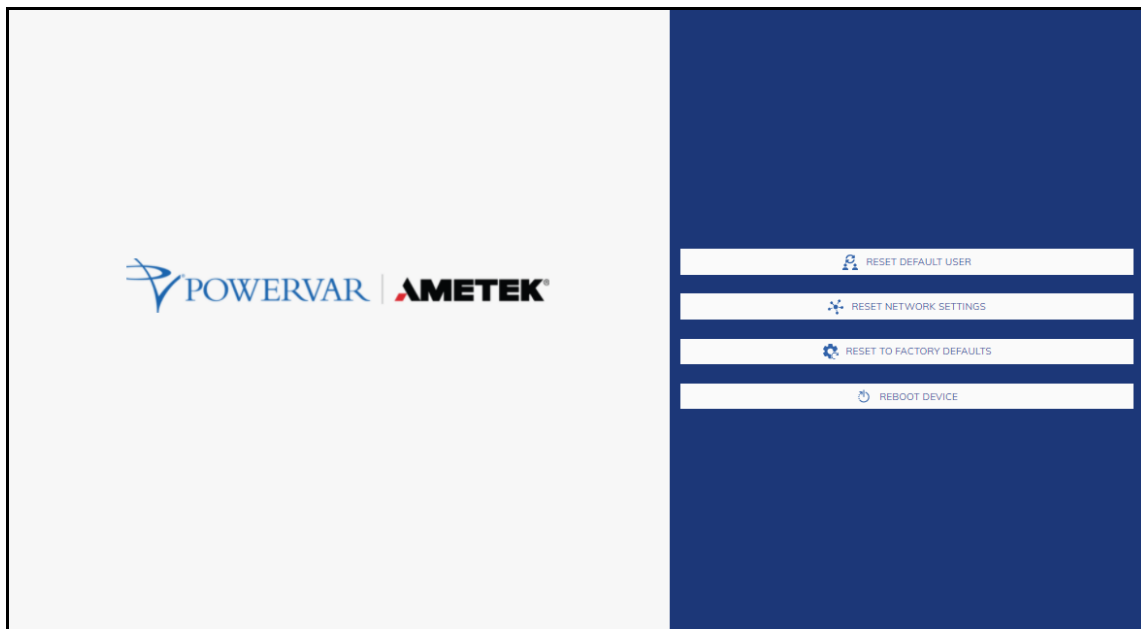

#### **4.3.1 Reset Default User**

This option resets the admin password to the default password Adm1nXXXXXX, where XXXXXX are the last six characters of the MAC address.

#### **4.3.2 Reset Network Settings**

This option resets the Network Settings of the iSite PRO to a factory default state.

#### **4.3.3 Reset To Factory Defaults**

This option resets the entire iSite PRO to a factory default state.

#### **4.3.4 Reboot Device**

This option reboots the iSite PRO without changing any configurations.

## **5.0 Application Programming Interfaces (APIs)**

The iSite PRO is designed for flexible communication and integration with diverse control and monitoring platforms.

### **5.1 HTTP/HTTPS REST**

iSite PRO includes an extensive HTTP API (HTTPS when security is enabled) in JSON format. Full protocol details are available at the [Powervar Connectivity Website Page](#).

### **5.2 SNMP**

SNMP v1 and v3 communications are intended to provide essential items for management. Read, Write, Table, and Trap objects will be included. Full protocol details, and the SNMP MIB, are available at the [Powervar Connectivity Website Page](#).

Support for the following MIB's is provided:

- RFC1213 (MIB II)
- RFC1628 (UPS ManaMOBUSgement Information Base)
- RFC1157
- ONEAC Environment Sensor Private MIB

## 6.0 Hardware Specifications

### 6.1 Specifications

<b>Network Interface</b>	10Base-T/100Base-TX IEEE 802.3 compliant Ethernet transceiver  Auto-negotiation to automatically select the highest link-up speed (10/100 Mbps) and duplex (half/full)
<b>Main Processor</b>	i.MX RT1050 processors based on Arm Cortex-M7 Core™ Platform  Integrated 10/100 M Ethernet controller with support for IEEE1588  Integrated FlexCAN module.
<b>Ethernet Controller</b>	
<b>Blue Bus</b>	
<b>Environmental</b>	Temperature: 0-40 degrees C (32-104 F)  Humidity: 5-90% non-condensing  Altitude: 2,000 m (6,500 ft) maximum
<b>Modbus/RTU</b>	RS422 and RS485 Half Duplex

### 6.2 Agency Approvals

<b>Safety</b>
EN 60950-1:2006 + A2:2013 Safety of ITE UL 60950-1, Edition 2
<b>Emissions</b>
EN 55032:2012 + AC:2013; Class A for A.2 (Class A) Radiated Emissions EN 55032:2012 + AC:2013; Class A for A.3 (Class A) Radiated Emissions EN 55032:2012 + AC:2013; Class A for A.8 (Class A) Conducted Emissions
<b>Immunity</b>
EN 55024:2010 EMC Immunity Characteristics EN 61000-4-2 Electrostatic Discharge Immunity EN 61000-4-3 Radiated Electromagnetic Immunity EN 61000-4-4 Fast Transients Immunity EN 61000-4-5 Surge Immunity EN 61000-4-6 Conducted Immunity EN 61000-4-8 Magnetic Field Immunity

## Appendix A – UPS Alarm Detail

SNMP Alarm ID	SNMP MIB OID Ref:	Log Entry & Condition Email Subject	Probable Cause
6	UpsAlarmInputBad	SNMP Trap only	Input power is out of limits or not present.
7	UpsAlarmOutputBad		An output condition is out of tolerance.

### SEVERE! Condition Codes

1	UpsAlarmBatteryBad	Module Battery Needs Replacing	UPS Battery needs replacing.
4	UpsAlarmDepletedBattery	Module Depleted Battery	Run time is just about zero.
5	UpsAlarmTempBad	Module Temperature Limit was Exceeded	Temperature near the battery is too hot.
8	UpsAlarmOutputOverload	Module Output Overload	Output load power is > 100% of rated capacity.
10	UpsAlarmBypassBad	Module Bypass Bad	The bypass is out of tolerance.
13	UpsAlarmChargerFailed	Module Charger Failed	Battery charger has failed, or its fuse has blown.
16	UpsAlarmFanFailure	Module Fan Failure	Fan failure detected.
17	UpsAlarmFuseFailure	Module Fuse Failure	Input circuit breaker is open, or charger fuse has blown.
18	UpsAlarmGeneralFault	Module Requires Servicing	A UPS fault was detected that is not specifically identified in the UPS protocol or defined in the standard MIB.
19	UpsAlarmDiagnosticTestFailed	Module Diagnostics Failed	A user-initiated test has failed.
20	UpsAlarmCommunicationsLost	Module Lost Communications	Adapter has Lost Serial Communications with the UPS.
26*	UpsAlarmBackfeedRelayFailure	Module Backfeed Relay Failure	Backfeed Relay Failure Detected.
27*	UpsAlarmBatteryFuseBlown	Module Battery Fuse Blown	Battery Fuse failure detected.
29*	UpsAlarmBatteryDegraded	Module Battery Degraded	The UPS detects that the Battery may need to be replaced soon.
no trap		Module Lost Communications While On Battery	Adapter has Lost Serial Communications with the UPS after the UPS reported an On Battery condition.
		System Load Exceeds Power Margin	The load reported by the UPS exceeds the user specified power margin.

SNMP Alarm ID	SNMP MIB OID Ref:	Log Entry & Condition Email Subject	Probable Cause
---------------	-------------------	-------------------------------------	----------------

### Warning! Condition Codes

2	UpsAlarmOnBattery	Module On Battery	UPS is running on battery power.
3	UpsAlarmLowBattery	Module Low Battery Condition	Run time left is less than configured low battery alarm value.
9	UpsAlarmOnBypass	Module On Bypass	The bypass is engaged by the UPS.
31	UpsAlarmGeneral Warning	Module General Warning	The UPS is indicating an unspecified fault condition.
	no trap	Module Running On Booster	The UPS is correcting a low input line condition without using battery reserves.

### Informational Condition Codes

11	UpsAlarmOutputOff AsRequested	Output Off As Requested	Ups Output Has been Turned off via UPS Com port command.
12	UpsAlarmUpsOff AsRequested	Module Off As Requested	Ups Has been Turned off via UPS Com port command.
14	UpsAlarmUpsOutputOff	Module Output Is Off	Confirmation that the UPS output is off, but the UPS control logic is still operating. This trap can only be sent if the adapter is powered from a source other than UPS output.
15	UpsAlarmUpsSystemOff	Module System Is Off	UPS output and control logic is off. Will likely never be seen.
21	UpsAlarmAwaitingPower	Module Awaiting Power	UPS output is off and the UPS is waiting for input power to be restored.
22	UpsAlarmShutdown Pending	Shutdown Pending On Module	A UPS shutdown timer has begun counting -- typically means UPS monitoring software has requested UPS output to be turned off after a delay period.
23	UpsAlarmShutdown Imminent	Shutdown Imminent On Module	Output shutdown will occur in approximately 5 seconds.
24	UpsAlarmTestIn Progress	Module Diagnostics Test in Progress	A user requested UPS test has begun.
25	UpsAlarmBattery Charging	Module Battery Charging	The UPS Battery is recovering from a recent discharge.
28	UpsAlarmSystemRestart Pending	System Restart Pending	The UPS is counting a user specified restart delay after AC input returns.
30	UpsAlarmAutonomy Calibration	Module Autonomy Calibration	The UPS is discharging the battery and calibrating its run time (autonomy) estimates.



Access additional product information  
and support on the web at  
[www.powervar.com](http://www.powervar.com)

A01-00157 REV C 02/17/2023 © 202m

AMETEK Powervar, Inc.



**USA Address:**

1450 Lakeside Drive  
Waukegan, IL 60085

1-800-369-7179  
(P) 847-596-7000  
(F) 847-596-7100

**Europe/Asia Address:**

Unit 5, Birch-Kembrey Park  
Swindon, Wilts SN2 8UU UK

(P) +44 1793 553980  
(F) +44 1793 535350

**Mexico Address:**

Camino a la Montana No. 178-  
101 & PB4

Fracc. Industrial La Perla,  
53340 Naucalpan, Edo De  
Mexico

(P) (52) 55 5363 5448