



# VTX SYSTEM TECHNICAL SUPPORT BULLETIN

TITLE: VTX-V25-CS-K COMPRESSION SUSPENSION KIT INSTALLATION PROCEDURE	NUMBER: VTX-05
Pages: 20	DATE: 12/10/2014

**Purpose:** PROCEDURE TO INSTALL VTX-V25-CS-K  
COMPRESSION SUSPENSION KIT  
IN ORDER TO CONVERT VTX V25 TO  
COMPRESSION-STYLE SUSPENSION

**Warranty Implications:** None

**Tools and Supplies:** See next page



## TOOLS AND SUPPLIES NEEDED:

- 5/32 ALLEN WRENCH
  - <http://www.matcotools.com/catalog/product/AW532TB/reviews/1/>
  - <http://www.hardwarestore.com/allen-wrenches-hex-keys--413.aspx>
- 7/16" BOX WRENCH
  - <http://www.homedepot.com/p/Husky-7-16-in-12-Point-SAE-FP-Combination-Wrench-HCW716/202916146>
  - <http://www.amazon.com/TEKTON-21491-16-Inch-Combination-Wrench/dp/B000NPPC50>
- 1/2" SOCKET (W/ RACHET DRIVER)
  - <http://www.alltradetools.com/catalog/mechanic-s-tool-sets/1457-640187-15-pc-1-2-dr-sae-socket-set.html>
  - <http://www.elise-shop.com/32mm-socket-12-for-driveshaft-nut-elise-s1-exige-s1-340r-all-models-p-353014.html>
- PHILLIPS HEAD SCREWDRIVER
  - <http://www.craftsman.com/craftsman-no-2-x-8-in-screwdriver-phillips/p-00941296000P?prdNo=5&blockNo=5&blockType=G5>
- LOCTITE 248 SEMISOLID STICK, MEDIUM STRENGTH THREADLOCKER, BLUE
  - <http://www.henkelna.com/product-search-1554.htm?nodeid=8797953851393>
  - [http://www.amazon.com/Loctite-Semisolid-Medium-Strength-Threadlocker/dp/B00JFJWDGG/ref=sr\\_1\\_5?s=industrial&ie=UTF8&qid=1409962670&sr=1-5&keywords=loctite+threadlocker+248](http://www.amazon.com/Loctite-Semisolid-Medium-Strength-Threadlocker/dp/B00JFJWDGG/ref=sr_1_5?s=industrial&ie=UTF8&qid=1409962670&sr=1-5&keywords=loctite+threadlocker+248)



## VTX-V25-CS-K COMPRESSION SUSPENSION KIT PARTS

QRP / Lanyard assembly



ASM/QRP Indicator Labels

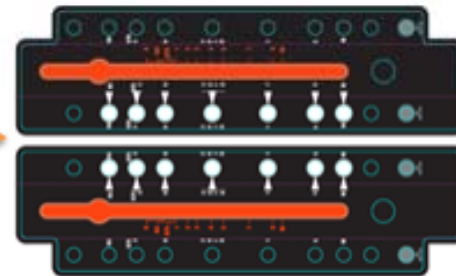

Slot Hinge Bar

Fixed pin and mount hardware for slot hinge bar

ASM Sled Bar

ASM Sled Bar Slider Handle and mount hardware



- Remove VTX V25 dolly board and position the cabinet on end as shown.

**CAUTION:** Ensure the side of the VTX V25 cabinet facing down is adequately protected from damage. It is strongly recommend that protective materials such as carpet or rubber mat are utilized in order to ensure that the VTX V25 is not scuffed or damaged during the upgrade process.

- Using a 5/32" allen wrench, remove the set screw from the VTX V25 rear hinge bar. Unpin the QRP's holding the VTX V25 rear hinge bar in place and remove the rear hinge bar from the VTX V25 suspension frame hinge bar tube.
- Once the rear hinge bar is removed, use non-corrosive cleaning solution to clean the entire surface of the VTX V25 suspension frame rear hinge bar tube in order to facilitate proper application of the VTX-V25-CS-K label.





- Using a phillips head screwdriver, remove the indicated screw that is holding the Quick Release Pin (QRP) lanyard attachment tab in place.

- Remove the existing QRP lanyard assembly

- Replace the existing QRP lanyard assembly with the longer length lanyard and QRP assembly that is included with the VTX-V25-CS-K package.

- Apply loctite blue to the threads of the previously-removed phillips head screw. Reinsert the screw and tighten to secure the new VTX-V25-CS-K QRP lanyard assembly to the VTX V25 cabinet.

- To confirm proper location and attachment of the new VTX-V25-CS-K QRP lanyard assembly, insert the QRP in the attachment position indicated here. When placed in this position the QRP should completely insert without any resistance and the lanyard should be fully extended.

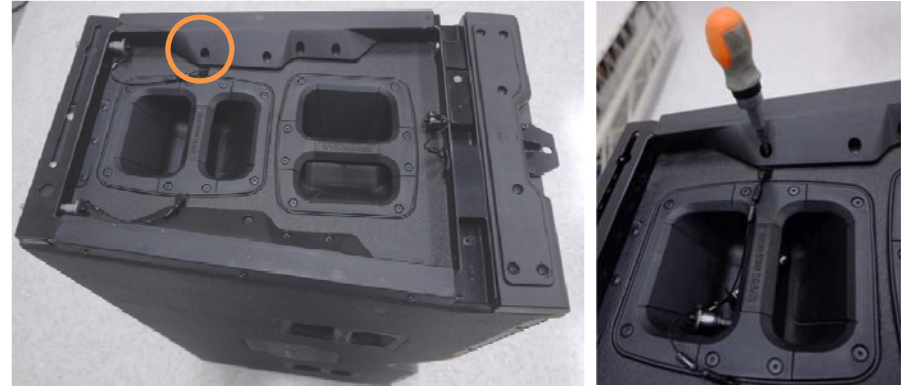

The next set of steps describes the process for properly attaching the VTX-V25-CS-K label to the suspension frame on VTX V25 cabinets.

In order to ensure proper mounting and successful long-term performance, it is absolutely critical that the VTX-V25-CS-K-LJ label attachment jig is used to attach labels.

**CONTACT YOUR LOCAL SALES REPRESENTATIVE TO ORDER A VTX-V25-CS-K-LJ LABEL ATTACHMENT JIB BEFORE PROCEEDING ANY FURTHER WITH THE CONVERSION PROCEDURE**

Test fit the VTX-V25-CS-K-LJ label jig installation fixture before applying the VTX-V25-CS-K suspension frame label in order to get a good feel for how to properly align and insert the fixture.

- The VTX-V25-CS-K-LJ properly applies labels to the VTX V25 suspension frame in one direction only. As shown, the smaller gap between the insertion peg and slot alignment feature should be oriented towards the top of the cabinet.
- If used backwards, the VTX-V25-CS-K-LJ will not properly align with the VTX V25 suspension frame and the gap between the insertion peg and slot alignment feature will prevent proper installation of the VTX-V25-CS-K-LJ

## VTX-V25-CS-K-LJ

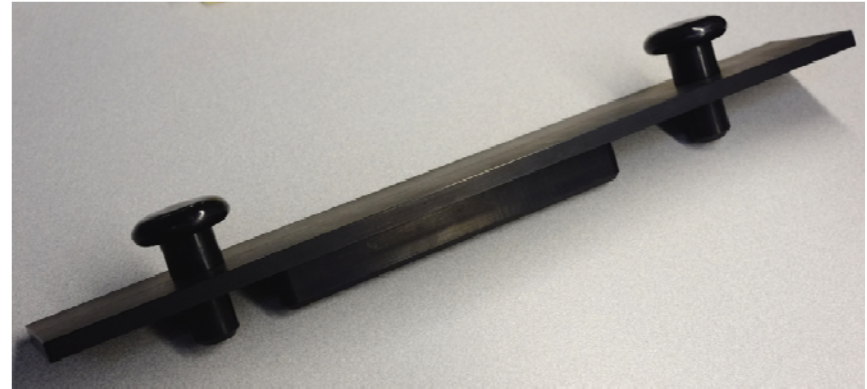

**CORRECT**



**INCORRECT**



- Two left/right labels are supplied with the VTX-V25-CS-K kit. In order to ensure that the correct VTX V25-CS-K label applied to the correct side of the VTX V25 enclosure suspension frame, refer to:
  - Front side protective cover orientation
  - Front handle VTX SERIES text orientation
- In the example shown on the right - with the front handle VTX SERIES text properly oriented (reading left to right) and the front side protective cover oriented on the right, white arrows on the label should be oriented toward the rear of the cabinet.

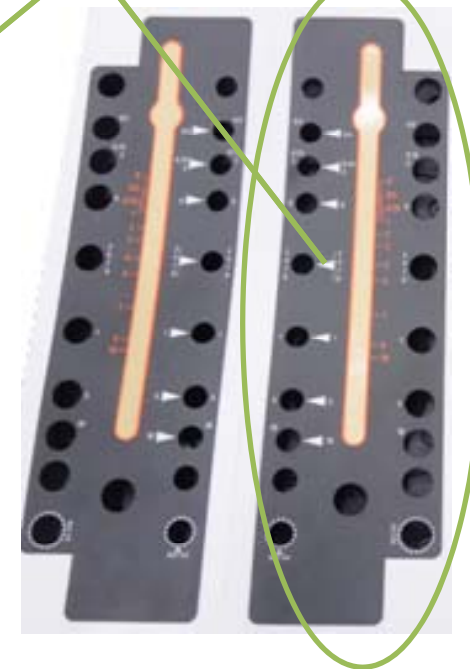
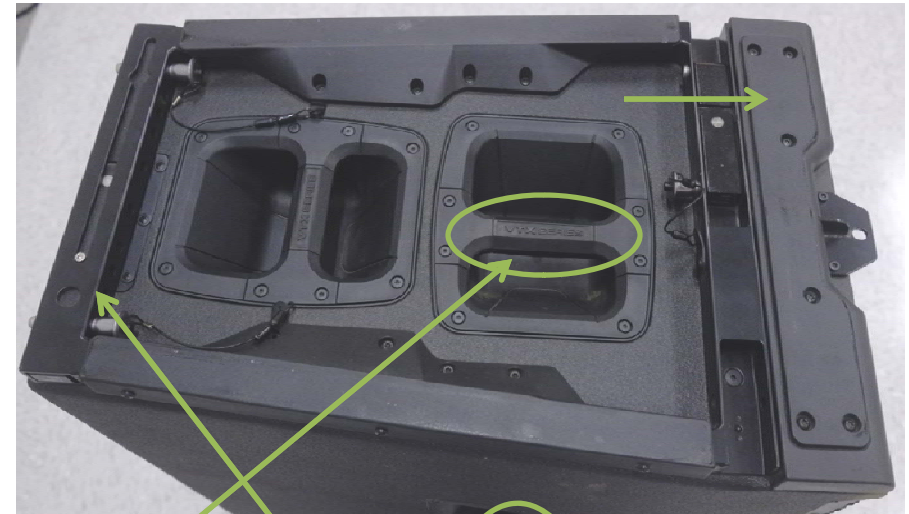

- When it is time to attach the other label to the opposite side of the VTX V25 cabinet a similar process can be utilized to ensure proper label attachment.
- In the example shown on the right - with the front handle VTX SERIES text properly oriented (reading left to right) and the front side protective cover oriented on the left, white arrows on the label should be oriented toward the rear of the cabinet.

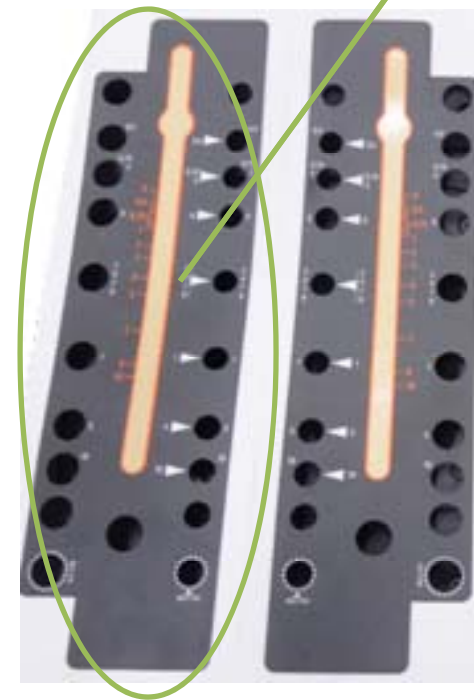
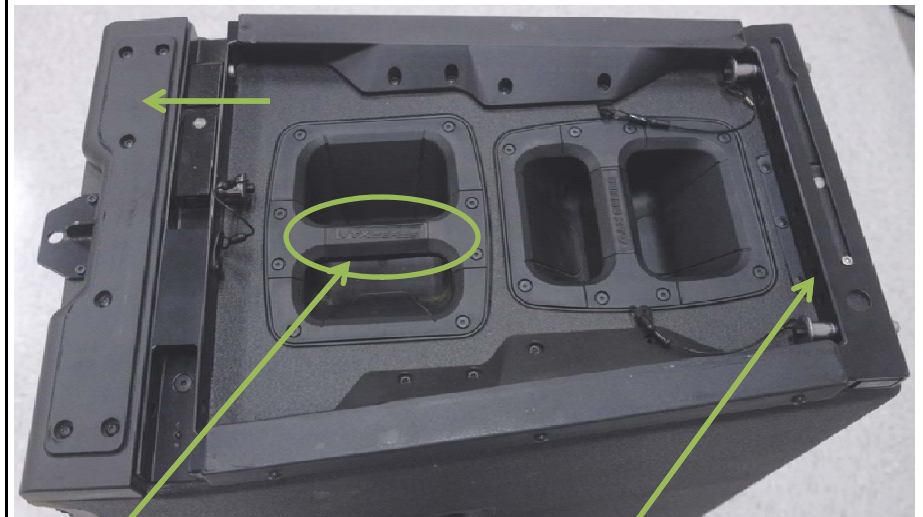



- Pre-attach the VTX V25-CS-K-LJ label attachment jig in the proper position with the insertion pegs and slot alignment feature properly oriented to mate with the VTX V25 suspension frame (see page 6).
- Remove the VTX V25-CS-K-LJ label attachment jig and flip it over (while maintaining correct orientation) so that insertion pegs are facing upwards
- Identify the correct label to be applied (see page 7,8). Note that the shorter side of the label is properly located so that when the VTX V25-CS-K-LJ is flipped over to insert into the VTX V25 suspension frame, it will fit properly into place.
- Once the correct VTX-V25-CS-K label has been identified, remove the label from the provided backing.
- When the label has been completely removed from it's backing, place it carefully onto the VTX-V25-CS-K-LJ label alignment jig with the adhesive side up and the label and jig in the correct orientation.

NOTE: The adhesive specified for the VTX-V25-CS-K label is very strong. Ensure that the label is lifted cleanly from the backing and no dirt or debris are introduced onto the adhesive surface. Also ensure that the surface of the VTX V25 suspension frame rear hinge bar tube has been thoroughly cleaned in order to facilitate proper label adhesion.

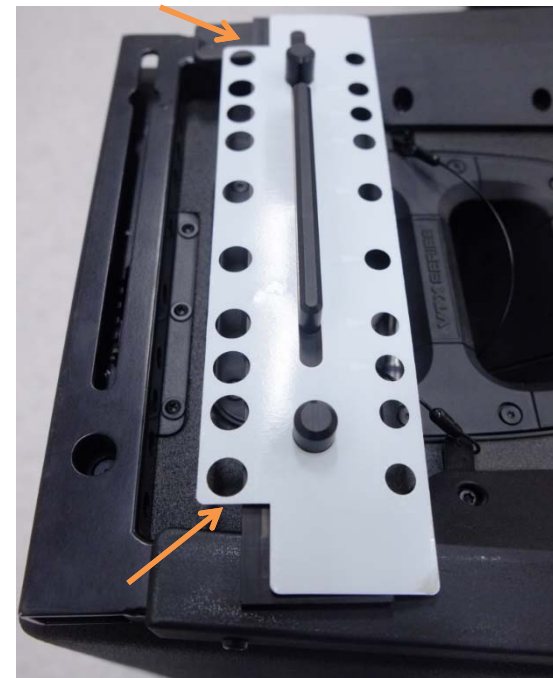
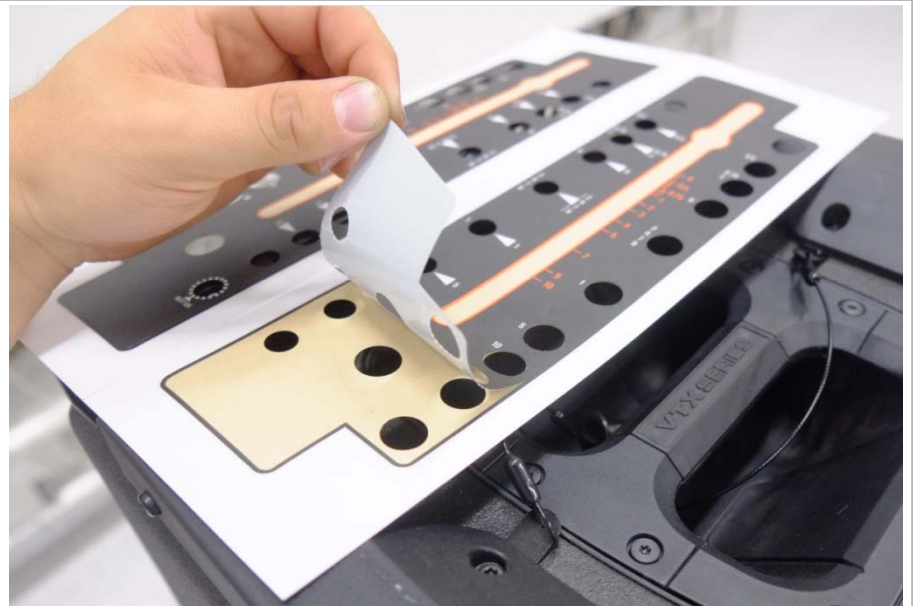

- This is a close up view of the proper orientation of the VTX V25-CS-K-LJ label alignment jig, in preparation to place the label jig into place and attach the VTX V25-CS-K label.
- Note the location of the gaps between the insertion pins and the slot alignment feature.
- When flipped over for adhesion, the longer side of the label will be on the exterior of the suspension frame tube and the shorter side of the label will be on the inside



- Carefully lift the VTX-V25-CS-K-LJ label alignment jig, taking care not to dislodge the VTX V25-CS-K suspension frame label.



- With gentle force, align insertion pegs and insert the VTX-V25-CS-K-LJ into place on the VTX V25 suspension frame. This will place the VTX V25-CS-K suspension frame label exactly into the proper location and flatten it so that the adhesive can be properly activated in the next steps.

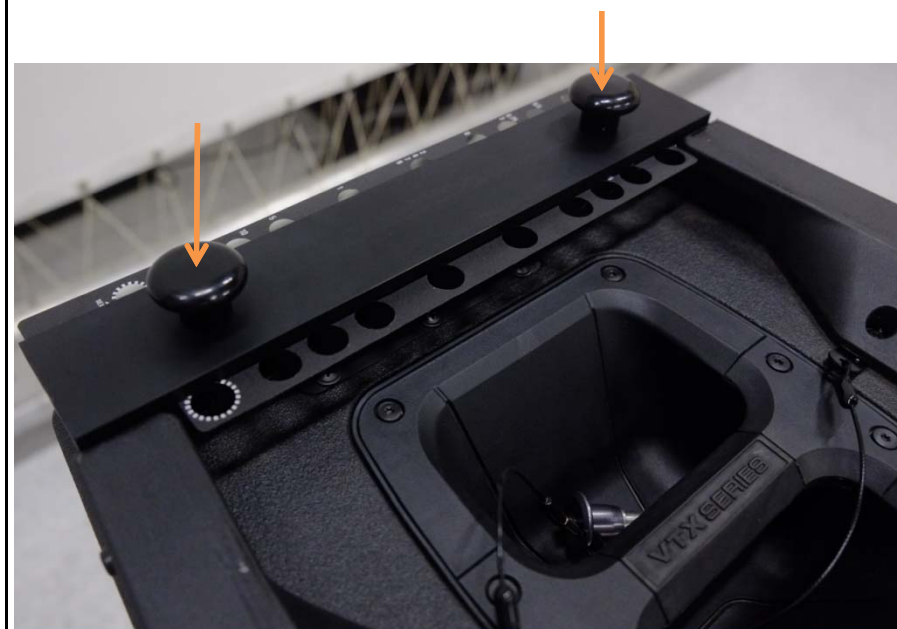



- Carefully lift the VTX-V25-CS-K-LJ label jig fixture from the VTX V25 suspension frame.

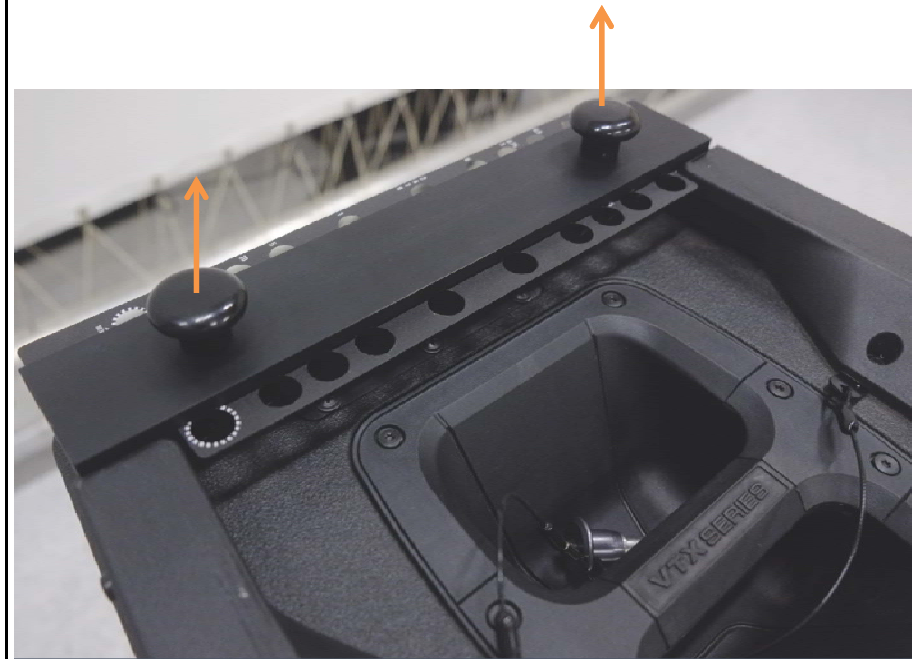

- The VTX V25-CS-K suspension frame label is now located in the proper place on the VTX V25 suspension frame. Confirm this by checking that the orange suspension frame slot outline does not interfere with the suspension frame slot in any way.

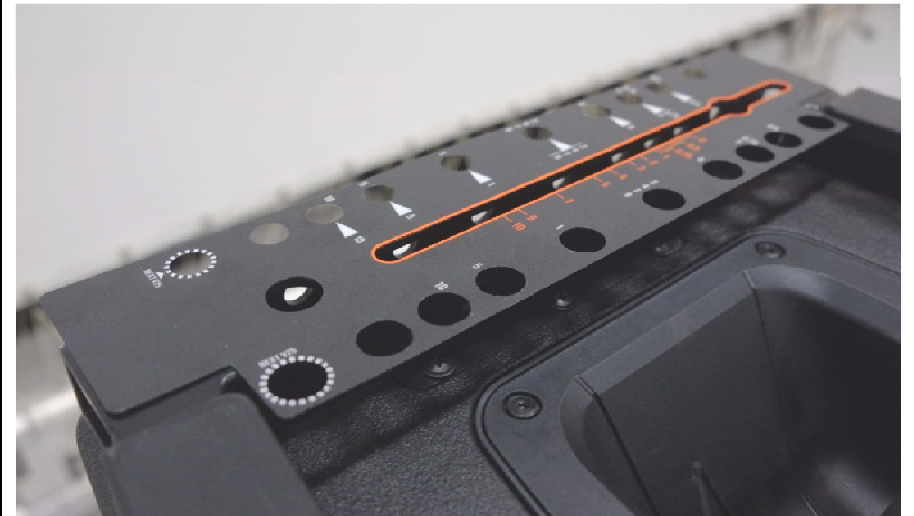

- To secure the VTX-V25-CS-K suspension frame label to the VTX V25 suspension frame, use the slot alignment feature of the VTX-V25-CS-K-LJ label jig fixture to press down on the label and permanently attach it to the VTX V25 suspension frame.
- Starting from one end of the VTX-V25-CS-K label and moving slowly while applying pressure, slide the slot alignment feature along the length of the VTX V25-CS-K suspension frame label (think squeegee).
- This action bonds the adhesive on the VTX V25-CS-K suspension frame label permanently to the VTX V25 suspension frame.

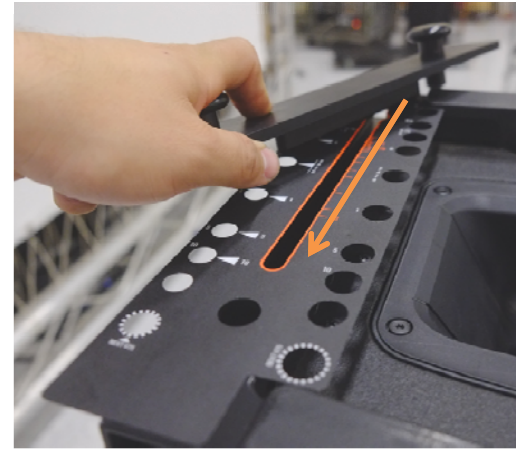

- To attach the sides of the VTX V25-CS-K suspension frame label, start from the center of the label and slide a thumb along the outside of the frame as shown.
- Make sure to push downwards and outwards to ensure that the VTX V25-CS-K suspension frame label both makes a proper turn around the corner of the VTX V25 suspension frame and does not form any air bubbles or creases in the process of being folded over.
- Use the end of VTX V25-CS-K-LJ label jig fixture to gently apply pressure and permanently attach the VTX V25-CS-K suspension frame label to the VTX V25 suspension frame side (similar procedure as when the top of the VTX V25-CS-K suspension frame label was bonded to the VTX V25 suspension frame).

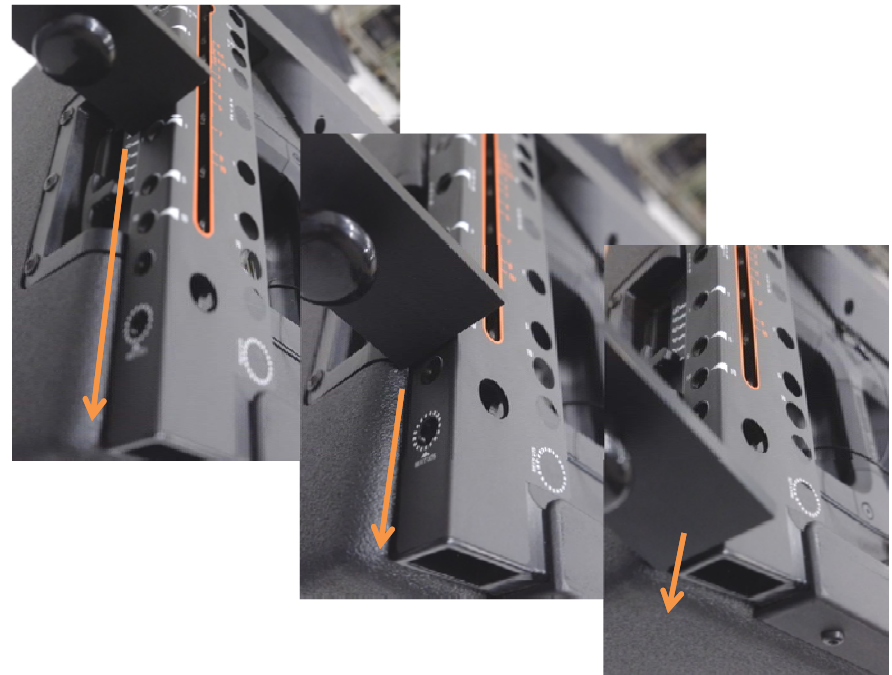

- Repeat the process for label attachment to the inside surface of the suspension frame tube
- Start from the center of the label and slide a thumb along the inside of the frame, pressing down and outwards to ensure that the VTX-V25-CS-K suspension frame label makes a proper turn around the corner of the VTX V25 suspension frame and does not form any air bubbles or creases in the process of being folded over.
- Using the edge of the VTX V25-CS-K-LJ label jig fixture, press down and along the surface of the VTX V25-CS-K suspension frame label to bond it to the inside surface of the VTX V25 suspension frame.





- Once the VTX V25-CS-K suspension frame label is secured to the VTX V25 suspension frame, insert the ASM sled bar into the VTX V25 suspension frame tube



- Ensure that the flat end of the ASM sled bar (with non-bevelled edges) is oriented upwards, towards the top of the cabinet.

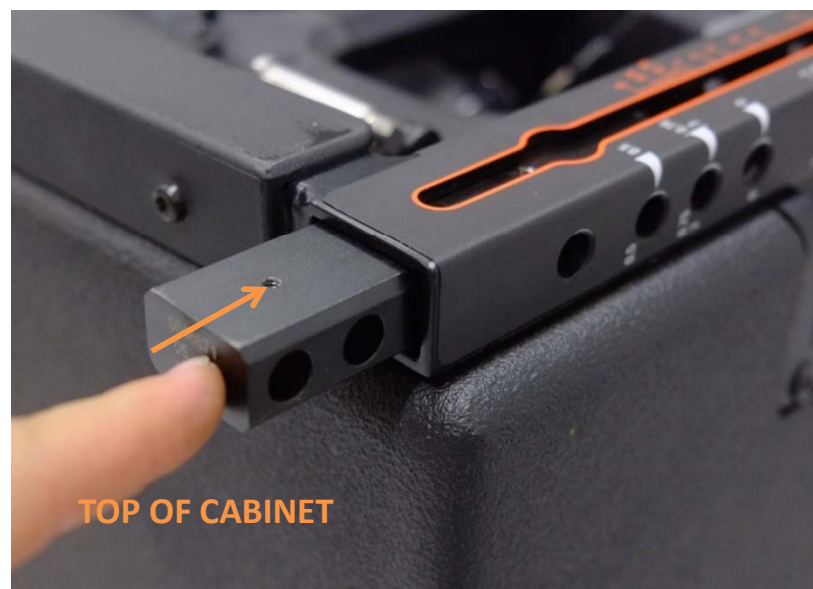

- When the ASM sled bar is fully inserted into the VTX V25 suspension frame tube, attach the ASM sled bar slider handle.
- Apply a small amount of threadlock to the fasteners supplied in the VTX V25-CS-K and use a 5/32" allen wrench to secure the screws that attach the ASM sled bar slider handle to the ASM sled bar.
- To confirm proper attachment, once the ASM sled bar slider handle is installed, move the ASM slider through it's full range of positions. The orange mark on the ASM slider handle should properly align with the orange 10 degree and 0 degree label indications. If the sled bar slider handle does not properly align, recheck to ensure that the ASM slider has been installed in the correct orientation.



- After the ASM slider has been properly installed, insert the slotted hinge bar into the top of the VTX V25 suspension frame hinge bar tube.



- Insert the fixed pin into the very top hole of the VTX V25 suspension frame hinge bar tube and pass it through the opening in the slotted hinge bar.





- On the opposite side of the fixed pin, position the lock nut that is included with the VTX-V25-CS-K kit.

- Use the 7/16" open end wrench and 1/2" socket to tighten the nut on the fixed pin and secure it to the VTX V25 suspension frame.
- It is recommended that the open end wrench remains stationary and the 1/2" socket is used in order to tighten the locking nut onto the fixed pin.

BE CAREFUL NOT TO LET MOVEMENT OF THE OPEN END OF THE 7/16" WRENCH SCRATCH OR DAMAGE THE VTX-V25-CS-K SUSPENSION FRAME LABEL



- Installation of the VTX V25-CS-K is now complete for this side of the VTX V25 enclosure.
- Proper installation can be confirmed by exercising the ASM sled bar and slotted hinge bar to their full extents, confirming they can be secured with the previously installed VTX V25-CS-K QRP lanyard assembly at the 0 and 10 degree positions.
- Repeat the above processes to install QRP lanyard assembly, label, ASM sled bar and slotted hingebar on the other side of the VTX V25 enclosure and verify proper functionality

