



PD SERIES

precision directivity®

PD500 Series

PD544 | PD564 | PD566 | PD595 | PD525S

User's Guide

Table of Contents

Product Descriptions	1
Installation Preparations.....	2
Connectivity	3
Suspending Loudspeakers.....	4
Important Safety Warning!	4
Are You New to Loudspeaker Suspension?.....	4
General Hardware Information.....	4
Attachment to Structures	4
Inspection & Maintenance.....	5
Safe Rigging	5
Eyebolt Installation	6
Weather Resistant Configurations for AE, PD, & VLA Series	7
Painting PD500 Series Loudspeaker Enclosures.....	9
Painting Weather Resistant PD Models.....	9
Specifications	10
PD544	10
PD564	11
PD566	12
PD595	13
PD525S	14
Replacement Parts	15
Warranty & Contacting JBL	15

Product Descriptions

The PD500 Series is a family of four 15" 2-way full-range horn-loaded systems and one dual 15" subwoofer. Finishes include black (standard) optional white (-WH), optional WRC (weather protection), and WRX (extreme weather protection). WRC & WRX models utilize stainless steel hardware, stainless steel foam backed grille and a 100 x 100 stainless vapor barrier for additional protection.

The four full-range model numbers and coverage patterns are as follows:

- PD544 utilizes a 40° horizontal x 40° vertical coverage pattern.
- PD564 utilizes a rotatable 60° horizontal x 40° vertical horn coverage pattern.
- PD566 utilizes a 60° horizontal x 60° vertical horn coverage pattern.
- PD595 utilizes a rotatable 90° horizontal x 50° vertical horn coverage pattern.

The above four models are EN54-24 certified for full-range passive mode, and are equipped with a JBL 2432H 38mm (1.5") exit, 75mm (3") voice coil compression driver, and a JBL 2031H 380mm (15") low-frequency transducer.

The dual 15" subwoofer model is the PD525S, equipped with two JBL 2275H 380mm (15") Differential Drive® dual voice coils — dual magnetic gap 100mm (4") voice coil with VGC™ (Vented Gap Cooling) drivers.

Connectivity is via CE-compliant covered barrier strip terminals. Barrier terminals accept up to 5.2mm (10 AWG) wire or maximum 9mm (.375") spade lugs.

All models share the same enclosure dimensions (H x W x D), 782.0mm x 783.0mm x 670.0mm (30.8" x 30.8" x 26.4"). See Fig 1.

All models are equipped with 20 M10 threaded attachment points (5 on top, 5 on bottom, 4 on each side, and 2 on rear).

For additional specifications, please refer to the spec sheets found at www.jblpro.com.

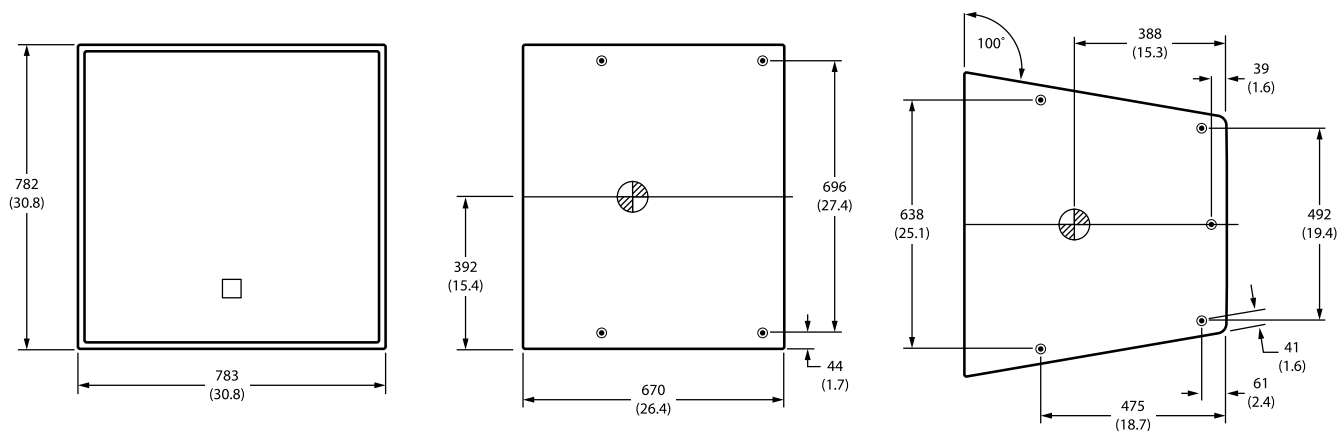

Fig 1

Installation Preparations

Inspect all loudspeakers for defects prior to overhead suspension and to ensure all parts are included. The input cup is shipped with a cover plate in place and gland nut with additional attachment hardware to ensure the input cup is secure and weather protected. All systems may be installed in a vertical or horizontal orientation.

Connectivity

PD500 Series full-range systems can be operated in full-passive mode or as a bi-amplified system. All models ship from the factory in full-passive mode as shown in Fig 2, and terminate as shown in Fig 3. For bi-amp mode, simply remove the four jumper wires on the input cup and terminate to the terminals indicated on the label (HF \pm , LF \pm) as shown in Fig 4.

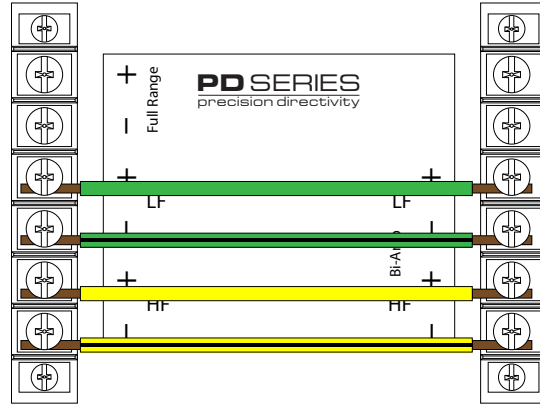

Fig 2 (full-passive mode — as shipped from the factory)

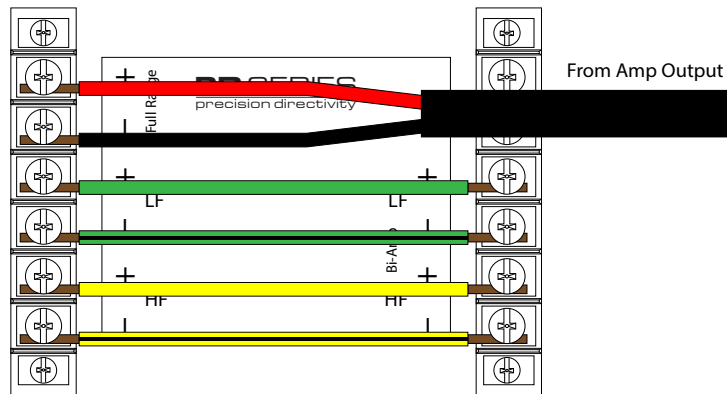

Fig 3 (passive mode)

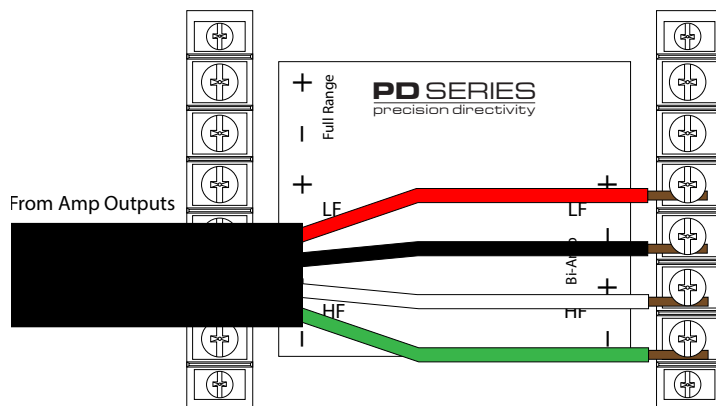

Fig 4 (bi-amp mode)

Suspending Loudspeakers

IMPORTANT SAFETY WARNING!

The information in this section has been assembled from recognized engineering data and is intended for informational purposes only. None of the information in this section should be used without first obtaining competent advice with respect to applicability to a given circumstance. None of the information presented herein is intended as a representation or warranty on the part of JBL. Anyone making use of this information assumes all liability arising from such use.

All information presented herein is based upon materials and practices common to North America and may not directly apply to other countries because of differing material dimensions, specifications, and/or local regulations. Users in other countries should consult with appropriate engineering and regulatory authorities for specific guidelines.

Correct use of all rigging hardware is required for secure system suspension. Careful calculations should always be performed to ensure that all components are used within their working load limits before the array is suspended. Never exceed the maximum recommended load ratings.

Before suspending any speaker system, always inspect all components (enclosure, rigging frames, pins, eyebolts, track fittings, etc.) for cracks, deformations, corrosion, and missing, loose, or damaged parts that could reduce strength and safety of the array. Do not suspend the speaker until the proper corrective action has been taken. Use only load-rated hardware when suspending Application Engineered™ Series and Precision Directivity® Series loudspeakers.

ARE YOU NEW TO LOUDSPEAKER SUSPENSION?

If so, you should do the following:

- Read and study JBL Technical Note Volume 1, Number 14: Basic Principles for Suspending Loudspeaker Systems (available at http://www.jblpro.com/pub/technote/tn_v1n14.pdf).
- Know the rules for the safe overhead suspension of loudspeakers.
- Attend a seminar, such as those recognized and recommended by the Entertainment Technician Certification Program – http://etcp.esta.org/cert_recognized/training_programs/rigging_list.htm.
- Meet and establish a relationship with a licensed mechanical or structural engineer. Get in the habit of asking them questions instead of guessing about their answers. Learn from what they tell you.
- Meet and discuss this aspect of your business with your Insurance Agent.
- Research and understand the codes, practices, and requirements in the venues where you intend to install and operate sound systems.

GENERAL HARDWARE INFORMATION

Any hardware used in an overhead suspension application must be load rated for the intended use. Generally, this type of hardware is available from rigging supply houses, industrial supply catalogs, and specialized rigging distributors. Local hardware stores do not usually stock these products. Hardware that is intended for overhead suspension will comply with ASME B30.20 and will be manufactured under product traceability controls. Compliant hardware will be referenced with a working load limit (WLL) and a traceability code.

ATTACHMENT TO STRUCTURES

A licensed Professional Engineer must approve the placement and method of attachment to the structure prior to the installation of any overhead object. The following performance standards should be provided to the Professional Engineer for design purposes; Uniform Building Code as applicable, Municipal Building Code as applicable, and Seismic Code as applicable.

The installation of the hardware and method of attachment must be carried out in the manner specified by the Professional Engineer. Improper installation may result in damage, injury, or death.

Suspending Loudspeakers

INSPECTION & MAINTENANCE

Suspension systems are comprised of mechanical devices and, as such, require regular inspection and routine maintenance to ensure proper functionality. JBL AE Series and PD Series loudspeakers must be inspected for fatigue at least annually. The inspection shall include a visual survey of all corners and load bearing surfaces for signs of cracking, water damage, de-lamination, or any other condition that may decrease the strength of the loudspeaker enclosure. Overhead suspension hardware must be inspected for fatigue at least annually. The inspection shall include a visual survey of the material for signs of corrosion, bending, or any other condition that may decrease the strength of the fastener. Additionally, any eyebolts shall be checked for possible spin-out from the enclosure. For all other hardware and fittings, refer to the hardware manufacturer's inspection and maintenance guidelines for process.

JBL is not responsible for the application of its products for any purpose or the misuse of this information for any purpose. Furthermore, JBL is not responsible for the abuse of its products caused by avoiding compliance with inspection and maintenance procedures or any other abuse.

Prior to suspending the system, an expert, trained and experienced in suspending loudspeaker systems, should inspect all rigging parts and components.

SAFE RIGGING



WARNING! SUSPENDING ANY LOUDSPEAKER SYSTEM SHOULD BE DONE BY QUALIFIED PERSONS FOLLOWING SAFE RIGGING STANDARDS.

The JBL PD500 Series loudspeakers are supplied with built-in internal brackets. The system is designed to facilitate the suspension of the loudspeaker by a qualified person familiar with rigging hardware and industry practices. Threaded M10 shouldered eyebolts are available for purchase from JBL Professional (part # 229-00009-01) for use when suspending PD500 Series enclosures utilizing this internal bracket system.

PD500 Series enclosures are capable of a maximum load of 470lbs/213kg from 2 points equally loaded. The single point maximum load is 235lbs/106kg. Improper installation may result in damage, injury, or death. Prior to suspending the system, an expert, trained and experienced in flying speaker systems, should inspect all rigging parts and components. A licensed Professional Engineer must approve the placement and method of attachment to the structure prior to the installation of any overhead object.

Suspending Loudspeakers

EYEBOLT INSTALLATION

Installation instructions follow:

1. Remove the M10 flat-head bolts from the enclosure (see Fig 5).
2. Screw the lifting eyebolt with fender washer into the threaded attachment point until the fender washer has contacted the enclosure (see Fig 6).
3. Continue to finger tighten the eyebolt until the correct alignment position is obtained — a maximum of one complete turn.
4. All hardware supplied by the user must be rated for overhead lifting to suspend the loudspeaker system.
5. Never install the eyebolt without the factory-supplied washer.

Eyebolts must be fully seated and oriented in the plane of pull. Over tightening the eyebolt with a wrench, screwdriver, etc., can result in a system failure and possible injury.



WARNING! EYEBOLTS MUST BE FULLY SEATED AND ORIENTED IN THE PLANE OF PULL AS SHOWN IN Fig 6. ALWAYS USE WASHERS TO DISTRIBUTE SUSPENSION LOADS.

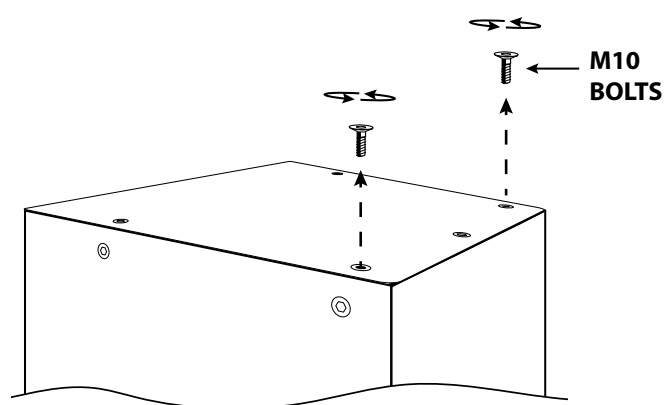

Fig 5

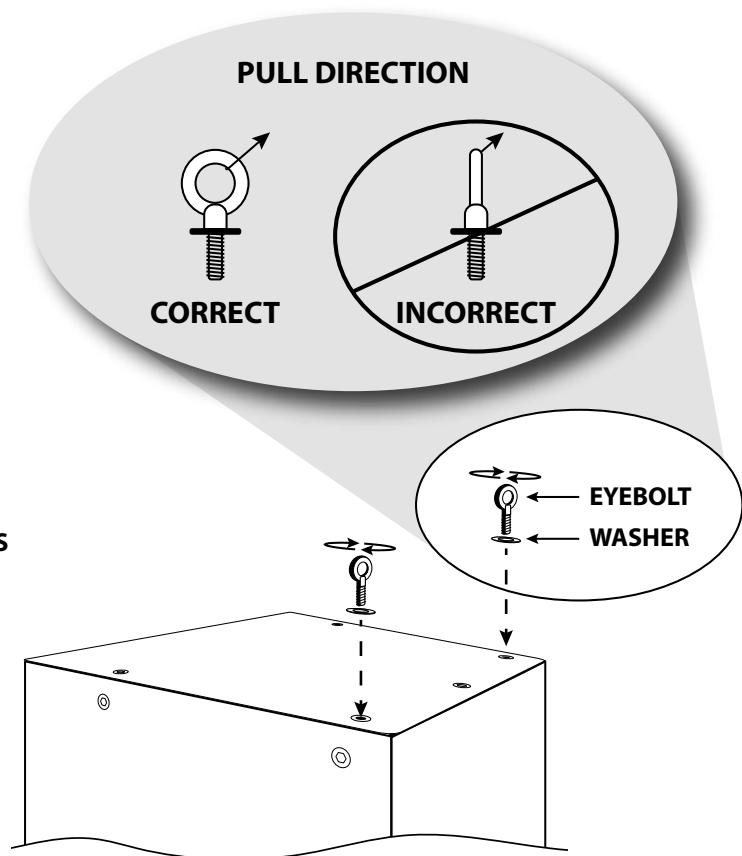

Fig 6

Weather Resistant Configurations for AE, PD, & VLA Series

JBL offers two standard levels of weather resistance for AE, PD, and VLA Series loudspeakers. **WRC** is intended for outdoor placement, where the loudspeaker will be sheltered from direct exposure to the elements. **WRX** is best suited for direct exposure to the elements or any extreme environment, such as tropical climate, beach areas, or other locations with high or low temperature extremes, salt air, high humidity, or rapid change in temperature.

Model Numbering – WR designation is a suffix to the standard model number. For example: **PD544-WRC** or **PD544-WRX**

Model Suffix	-WRC	-WRX
Environmental Ratings	Covered/Protected Outdoor Areas	Direct Exposure or Extreme Environment
	IP55 per IEC 529	IP56 per IEC 529

ENCLOSURE

Covering and Finish	<p><u>Exterior:</u> 0.060" (1.5mm) thick DuraFlex™ coating.</p> <p><u>Interior:</u> Wood sealer.</p>	<p><u>Exterior:</u> Course Texture 0.060" (1.5mm) thick Fiberglass, all corners wrapped with fiberglass cloth for maximum structural reinforcement.</p> <p><u>Interior:</u> Gelcoat sealed.</p>
Dimensions	LARGER than standard AE Series cabinets. Standard AE Series brackets do NOT fit these cabinets. Visit the JBL Professional website for drawings at: http://www.jblpro.com/catalog/support/getfile.aspx?doctype=3&docid=1970 . Or, contact JBL Professional for dimensional information.	
Standard Color	LIGHT GRAY, similar to RAL 7035 and Pantone PMS 428 C (contact JBL Professional for availability).	
Optional Colors	JBL Black (-BK), similar to RAL 9004; JBL AE White (-WH), similar to RAL 9010 (contact JBL Professional for availability).	
Custom Colors	Contact JBL Professional for colors, pricing, and availability.	
Horn Orientation	Rotating the horn in the field is not recommended. Default horn orientation is wider horizontal coverage, narrower vertical coverage with vertical cabinet orientation, same as standard versions. To order with horn rotated, add "-H" (Ex: PD544-WRX-H).	
Enclosure	Exterior grade plywood, exterior grade glues, fully captive baffle.	
Hardware	Stainless steel and heavily zinc-plated hardware throughout.	

GRILLE

Shape	Flat front.
Grille Material	Perforated stainless steel, vinyl dipped, light gray color.
Grille Backing	Black open cell foam over stainless steel vapor-barrier.

Weather Resistant Configurations for AE, PD, & VLA Series

Model Suffix	-WRC	-WRX
--------------	------	------

INPUT & NETWORK

Input Connection & Cable	Sealed gland nut, permanently attached 20 ft (6 m) captive jacketed cable, unterminated. AE Compact models are equipped with a 6 ft (2 m) captive jacketed cable, unterminated. Cable rated for permanent outdoor installation: UV, ozone, and water resistant. Custom cable lengths are available, contact JBL Pro for details. Cable Diameters: (14/2 .350" - .380"); (14/4 .350" - .380"); (14/6 .400" - .450").
Network Mode	Comes standard in "full-passive" mode. For bi-amp mode, reconfigure the input plate as shown in the section titled " Connectivity " on page 3.

COMPONENT TREATMENT

Transducers	Cones treated for water resistance, metal parts urethane-coated.
Passive Crossover Network	Conformal urethane coating.

Painting PD500 Series Loudspeaker Enclosures

JBL PD Series loudspeakers are available in black, white, or unfinished. When ordering, the default color is always black. White is signified by a –WH suffix on the model number. Unfinished models are signified with a –UF suffix and are delivered “paint ready”. JBL recommends that for custom color installations, the unfinished versions (-UF) be ordered and painted as required. If, however, you wish to paint an enclosure over the JBL DuraFlex™ finish, the instructions below should be used as a general guide.

NOTE: Unfinished and custom color models are not EN54-24 compliant.

DuraFlex is a multi-layer finish. The top aliphatic layer provides a surface to which most paints bond.

NOTE: Some JBL portable loudspeaker models do not include a top aliphatic coating — these models are not paintable. All standard PD Series loudspeakers do include a top aliphatic coating and are paintable.

PAINTING WEATHER RESISTANT PD MODELS

Most PD models are available in two levels of weather-resistant models. Weather-resistant models are signified by a –WRC or –WRX suffix to the standard product model.

IMPORTANT: Simply painting a non-weather-resistant speaker is NOT acceptable protection for outdoor use.

Internal Protection – The WRC and WRX models are constructed with necessary additional internal protection, including: full internal surface sealant to protect the wood from the inside, special corrosion-resistant internal hardware, weather protection for the cones, protective coating for the metal parts on the back of the drivers, protective coating on crossover network, waterproof glues, and special grille backing that breaks up driving rain. For speakers that will be used outdoors, always start with a WRC (DuraFlex finish) or WRX (fiberglass finish) as the base model to insure proper construction for outdoor use.

Painting WRC Enclosures – Models with the WRC-level of weather resistant are coated with an extra-thick DuraFlex finish. Follow the same instructions in the sections above, which apply to all models with DuraFlex finish.

Painting WRX Enclosures – WRX-level weather resistant models have a fiberglass finish. Follow standard procedures for painting over fiberglass.

Specifications

PD544

Frequency Range (-10 dB) :	50 Hz to 20 kHz
Frequency Response (± 3 dB):	90 Hz to 17 kHz
Coverage Pattern:	40° x 40°
Directivity Factor (Q):	31.5
Directivity Index (DI):	15 dB
Crossover Modes:	Bi-amp / Passive switchable
Passive Crossover:	1.2 kHz
Transducer Power Rating (AES):	LF: 450W 2 hrs, 300W 100 hrs HF: 75W 2 hrs, 50W 100 hrs
System Power Rating:	Passive Mode: 500W 2 hrs, 300W 100 hrs (IEC)
Max SPL:	Bi-amp: LF – 133 cont (139 peak) HF – 134 cont (140 peak) Passive: 133 cont (139 peak)
System Sensitivity (1W @ 1m):	Passive Mode: 106 dB SPL
Nominal Impedance:	8 ohms
Low Frequency Driver:	JBL 2031H, 380mm (15") driver with 38mm (3") voice coil
Nominal Impedance:	8 ohms
Sensitivity:	106 dB (avg 300 Hz – 1.3 kHz) (1W, 1m within operational band)
High Frequency Driver:	JBL2432H, 38mm (3") voice coil
Nominal Impedance:	8 ohms
Sensitivity (1W @ 1m):	115 dB (avg 1.5 K – 5 kHz)
Waveguide:	HF: PT-H44HF-1, 300 x 300mm (12 x 12 in)
Enclosure:	Trapezoidal with 10° side angles, 18mm exterior grade 11-ply Finnish birch plywood
Suspension Attachments:	20 points (5 top & bottom, 4 each side, 2 rear), M10 threaded hardware (eyebolts NOT included)
Standard Finish:	Black DuraFlex™, White (-WH) available upon request Note: Unfinished and custom color models are not EN54-24 compliant.
Optional Weather Resistant Versions:	WRC for outdoor placement where loudspeakers will be sheltered from direct exposure. WRX for direct exposure or extreme environments. See WRC/WRX configuration details above.
Grille:	Powder coated 14 gauge perforated steel, acoustically transparent and weather resistant cloth backing.
Input Connectors:	CE Compliant covered barrio strip terminals. Terminals accept up to 5.2 sq mm (10 AWG) wire or max width 9mm (.375) spade lugs.
Environmental Specs:	Mil-Std 810; IP-x3 per IEC529. For higher environmental ratings, use WRC or WRX.
Dimensions (H x W x D):	782.0 x 783.0 x 670 mm (30.8 x 30.8 x 26.4 in)
Net Weight:	69.0 kg (152 lbs.)
Optional Accessory:	229-00009-01 kit of three M10 x 35 mm forged shoulder eyebolts

Specifications

PD564

Frequency Range (-10 dB):	50 Hz to 20 kHz
Frequency Response (± 3 dB):	90 Hz to 17 kHz
Coverage Pattern:	60° x 40°
Directivity Factor (Q):	20.0
Directivity Index (DI):	13 dB
Crossover Modes:	Bi-amp / Passive switchable
Passive Crossover:	1.2 kHz
Transducer Power Rating (AES):	LF: 450W 2 hrs, 300W 100 hrs HF: 75W 2 hrs, 50W 100 hrs
System Power Rating:	Passive Mode: 500W 2 hrs, 300W 100 hrs (IEC)
Max SPL:	Bi-amp: LF – 133 cont (139 peak) HF – 133 cont (139 peak) Passive: 132 cont (138 peak)
System Sensitivity (1W @ 1m):	Passive Mode: 105 dB SPL
Nominal Impedance:	8 ohms
Low Frequency Driver:	JBL 2031H, 380mm (15") driver with 38mm (3") voice coil
Nominal Impedance:	8 ohms
Sensitivity:	106 dB (avg 300 Hz – 1.3 kHz) (1W, 1m within operational band)
High Frequency Driver:	JBL2432H, 38mm (3") voice coil
Nominal Impedance:	8 ohms
Sensitivity (1W @ 1m):	114 dB (avg 1.5 K – 5 kHz)
Waveguide:	HF: PT-H64HF-1, 300 x 300mm (12 x 12 in)
Enclosure:	Trapezoidal with 10° side angles, 18mm exterior grade 11-ply Finnish birch plywood
Suspension Attachments:	20 points (5 top & bottom, 4 each side, 2 rear), M10 threaded hardware (eyebolts NOT included)
Standard Finish:	Black DuraFlex™, White (-WH) available upon request Note: Unfinished and custom color models are not EN54-24 compliant.
Optional Weather Resistant Versions:	WRC for outdoor placement where loudspeakers will be sheltered from direct exposure. WRX for direct exposure or extreme environments. See WRC/WRX configuration details above.
Grille:	Powder coated 14 gauge perforated steel, acoustically transparent and weather resistant cloth backing.
Input Connectors:	CE Compliant covered barrio strip terminals. Terminals accept up to 5.2 sq mm (10 AWG) wire or max width 9mm (.375) spade lugs.
Environmental Specs:	Mil-Std 810; IP-x3 per IEC529. For higher environmental ratings, use WRC or WRX.
Dimensions (H x W x D):	782.0 x 783.0 x 670 mm (30.8 x 30.8 x 26.4 in)
Net Weight:	69.0 kg (152 lbs.)
Optional Accessory:	229-00009-01 kit of three M10 x 35 mm forged shoulder eyebolts

Specifications

PD566

Frequency Range (-10 dB):	50 Hz to 20 kHz
Frequency Response (± 3 dB):	90 Hz to 17 kHz
Coverage Pattern:	60° x 60°
Directivity Factor (Q):	16
Directivity Index (DI):	12 dB
Crossover Modes:	Bi-amp / Passive switchable
Passive Crossover:	1.2 kHz
Transducer Power Rating (AES):	LF: 450W 2 hrs, 300W 100 hrs HF: 75W 2 hrs, 50W 100 hrs
System Power Rating:	Passive Mode: 500W 2 hrs, 300W 100 hrs (IEC)
Max SPL:	Bi-amp: LF – 133 cont (139 peak) HF – 133 cont (139 peak) Passive: 131 cont (137 peak)
System Sensitivity (1W @ 1m):	Passive Mode: 104 dB SPL
Nominal Impedance:	8 ohms
Low Frequency Driver:	JBL 2031H, 380mm (15") driver with 38mm (3") voice coil
Nominal Impedance:	8 ohms
Sensitivity:	106 dB (avg 300 Hz – 1.3 kHz) (1W, 1m within operational band)
High Frequency Driver:	JBL2432H, 38mm (3") voice coil
Nominal Impedance:	8 ohms
Sensitivity (1W @ 1m):	114 dB (avg 1.5 K – 5 kHz)
Waveguide:	HF: PT-H66HF-1, 300 x 300mm (12 x 12 in)
Enclosure:	Trapezoidal with 10° side angles, 18mm exterior grade 11-ply Finnish birch plywood
Suspension Attachments:	20 points (5 top & bottom, 4 each side, 2 rear), M10 threaded hardware (eyebolts NOT included)
Standard Finish:	Black DuraFlex™, White (-WH) available upon request Note: Unfinished and custom color models are not EN54-24 compliant.
Optional Weather Resistant Versions:	WRC for outdoor placement where loudspeakers will be sheltered from direct exposure. WRX for direct exposure or extreme environments. See WRC/WRX configuration details above.
Grille:	Powder coated 14 gauge perforated steel, acoustically transparent and weather resistant cloth backing.
Input Connectors:	CE Compliant covered barrio strip terminals. Terminals accept up to 5.2 sq mm (10 AWG) wire or max width 9mm (.375) spade lugs.
Environmental Specs:	Mil-Std 810; IP-x3 per IEC529. For higher environmental ratings, use WRC or WRX.
Dimensions (H x W x D):	782.0 x 783.0 x 670 mm (30.8 x 30.8 x 26.4 in)
Net Weight:	69.0 kg (152 lbs.)
Optional Accessory:	229-00009-01 kit of three M10 x 35 mm forged shoulder eyebolts

Specifications

PD595

Frequency Range (-10 dB):	50 Hz to 20 kHz
Frequency Response (± 3 dB):	90 Hz to 17 kHz
Coverage Pattern:	90° x 50°
Directivity Factor (Q):	10
Directivity Index (DI):	10 dB
Crossover Modes:	Bi-amp / Passive switchable
Passive Crossover:	1.2 kHz
Transducer Power Rating (AES):	LF: 450W 2 hrs, 300W 100 hrs HF: 75W 2 hrs, 50W 100 hrs
System Power Rating:	Passive Mode: 500W 2 hrs, 300W 100 hrs (IEC)
Max SPL:	Bi-amp: LF – 133 cont (139 peak) HF – 132 cont (138 peak) Passive: 131 cont (137 peak)
System Sensitivity (1W @ 1m):	Passive Mode: 104 dB SPL
Nominal Impedance:	8 ohms
Low Frequency Driver:	JBL 2031H, 380mm (15") driver with 38mm (3") voice coil
Nominal Impedance:	8 ohms
Sensitivity:	106 dB (avg 300 Hz – 1.3 kHz) (1W, 1m within operational band)
High Frequency Driver:	JBL2432H, 38mm (3") voice coil
Nominal Impedance:	8 ohms
Sensitivity (1W @ 1m):	113 dB (avg 1.5 K – 5 kHz)
Waveguide:	HF: PT-H95HF-1, 300 x 300mm (12 x 12 in)
Enclosure:	Trapezoidal with 10° side angles, 18mm exterior grade 11-ply Finnish birch plywood
Suspension Attachments:	20 points (5 top & bottom, 4 each side, 2 rear), M10 threaded hardware (eyebolts NOT included)
Standard Finish:	Black DuraFlex™, White (-WH) available upon request Note: Unfinished and custom color models are not EN54-24 compliant.
Optional Weather Resistant Versions:	WRC for outdoor placement where loudspeakers will be sheltered from direct exposure. WRX for direct exposure or extreme environments. See WRC/WRX configuration details above.
Grille:	Powder coated 14 gauge perforated steel, acoustically transparent and weather resistant cloth backing.
Input Connectors:	CE Compliant covered barrio strip terminals. Terminals accept up to 5.2 sq mm (10 AWG) wire or max width 9mm (.375) spade lugs.
Environmental Specs:	Mil-Std 810; IP-x3 per IEC529. For higher environmental ratings, use WRC or WRX.
Dimensions (H x W x D):	782.0 x 783.0 x 670 mm (30.8 x 30.8 x 26.4 in)
Net Weight:	69.0 kg (152 lbs.)
Optional Accessory:	229-00009-01 kit of three M10 x 35 mm forged shoulder eyebolts

Specifications

PD525S

Frequency Range (-10 dB):	28 Hz to 3.8 kHz
Frequency Response (± 3 dB):	40 Hz to 1.1 kHz
Transducer Power Rating (AES):	2000W (8000W peak) 2 hrs
System Power Rating:	1000W 100 hr.
Max SPL:	135 cont (141 peak)
System Sensitivity (1W @ 1m):	102 dB SPL (avg 40 Hz – 1 kHz)
Nominal Impedance:	4 ohms in parallel-drive mode, 2 x 8 ohms in discrete drive mode
Low Frequency Driver:	2 x JBL 2267H, 380mm (15") Dual Coil – Dual Gap Differential Drive®, VGC™ drivers with 100mm (4") voice coil
Enclosure:	Trapezoidal with 10° side angles, 18mm exterior grade 11-ply Finnish birch plywood
Suspension Attachments:	20 points (5 top & bottom, 4 each side, 2 rear), M10 threaded hardware (eyebolts NOT included)
Standard Finish:	Black DuraFlex™, White (-WH) available upon request Note: Unfinished and custom color models are not EN54-24 compliant.
Optional Weather Resistant Versions:	WRC for outdoor placement where loudspeakers will be sheltered from direct exposure. WRX for direct exposure or extreme environments. See WRC/WRX configuration details above.
Grille:	Powder coated 14 gauge perforated steel, acoustically transparent and weather resistant cloth backing.
Input Connectors:	CE Compliant covered barrio strip terminals. Terminals accept up to 5.2 sq mm (10 AWG) wire or max width 9mm (.375) spade lugs.
Environmental Specs:	Mil-Std 810; IP-x3 per IEC529. For higher environmental ratings, use WRC or WRX.
Dimensions (H x W x D):	782.0 x 783.0 x 670 mm (30.8 x 30.8 x 26.4 in)
Net Weight:	53.4 kg (118 lbs.)
Optional Accessory:	229-00009-01 kit of three M10 x 35 mm forged shoulder eyebolts

Please note, model PD525S does not meet EN54-24 standards for voice evacuation announcements due to limited bandwidth.

Replacement Parts

There are no user serviceable parts inside these speakers. Refer servicing to an authorized JBL Service Center. For the name of an authorized Service Center in your area, contact JBL Professional at the address listed below.

WARRANTY & CONTACTING JBL

These products are designed and backed by JBL Professional, the world leader in sound reinforcement. For complete JBL warranty information or to order replacement parts, contact JBL Professional:

WITHIN THE UNITED STATES:

JBL Professional
8500 Balboa Blvd.
Northridge, CA 91329, USA

In the USA you may call Monday through Friday 8:00 am to 5:00 pm Pacific Coast Time.
(818) 894-8850

IN OTHER AREAS THROUGHOUT THE WORLD:

Contact the JBL Professional Distributor in your country.

A list of JBL Professional Distributors and U.S. Service Centers can be attained from the JBL Professional WWW.JBLPRO.COM website.

Brand: JBL Professional

Family Name: PD500 Series

Model Names: PD544, PD564, PD566, PD595, PD525S, PD544-WH, PD564-WH, PD566-WH, PD595-WH, PD525S-WH, PD544-WRC, PD564-WRC, PD566-WRC, PD595-WRC, PD525S-WRC, PD544-WRX, PD564-WRX, PD566-WRX, PD595-WRX, PD525S-WRX.

We, Harman International, declare under our sole responsibility that the product, to which this declaration relates, is in conformity with the following directives.

Copies of all Technical Data, Safety Data and EMC reports can be obtained by contacting Frank Lacelle at frank.lacelle@harman.com.

I certify that the product identified above conforms to the requirements of the the Low Voltage Directive 2006/95/EC and the Waste from Electrical and Electronic Equipment Directive 2002/96/EC RoHS.

<http://www.jblpro.com/catalog/support/getfile.aspx?docid=1525&doctype=3>

JBL Professional, part of the Harman International group of companies, declares that the products produced under the aforementioned brand names are designed and produced as professional audio speakers and therefore outside of the intended scope of the European Commission Regulation (EC) 1275/2008 of 17 December 2008 implementing Directive 2005/32/EC of the European Parliament and of the Council with regard to ecodesign requirements for standby and off mode electric power consumption of electrical and electronic household and office equipment.

<http://www.jblpro.com/catalog/support/getfile.aspx?docid=1528&doctype=3>

Harman International expects our suppliers and business partners to be aware of their obligations under REACH and expects any substances or products within the scope of REACH to be pre-registered before December 1, 2008. The product identified above meet REACH requirements for chemicals designated by the European Chemicals Agency (ECHA) as Substances of Very High Concern (SVHC). Our current products are exempt from REACH pre-registration and later registration activities. We provide separate E.U. Reduction of Hazardous Substances documentation for our RoHS compliant products. None of the products listed above have SVHC's over the 0.1% threshold for any chemical on the Candidate list.

<http://www.jblpro.com/catalog/support/getfile.aspx?docid=1529&doctype=3>

The WEEE directive (2002/96/EC) places an obligation on all EU-based manufacturers and importers to take back electronic products at the end of their useful life. JBL, through its agent, accepts its responsibility to finance the cost of treatment and recovery of redundant WEEE in accordance with the specific WEEE recycling requirements. All of our products are marked with the WEEE symbol; this indicates that this product must NOT be disposed of with other waste. Instead it is the user's responsibility to dispose of their waste electrical and electronic equipment by handing it over to an approved re-processor, or by returning it to JBL's agent for reprocessing. For more information about where you can send your waste equipment for recycling, please contact your local distributor.

<http://www.jblpro.com/catalog/support/getfile.aspx?docid=1527&doctype=3>

JBL Professional, Northridge, California, USA; 07/16/2015
(Place and Date of issue)

Frank
Digitally signed by Frank
DN: cn=Frank, o=JBL Professional,
ou=Loudspeaker, email=frank.
lacelle@harman.com, c=US
Date: 2016.04.11 14:14:50 -0700

Frank Lacelle, Compliance Manager
(Name and function of authorized person)



JBL Professional
8500 Balboa Blvd. P.O. Box 2200
Northridge, CA 91329, U.S.A.

Part Number: 5073594-A