

# Technical Support Guide

## Enova DGX Board Replacement

### Applicability

This *Technical Support Guide* covers adding, removing, and replacing procedures for Enova DGX boards listed in the tables below. *DGX HDMI 4K60 Input and Output, DXLink 4K60 Input and Output, DXLink Fiber 4K60 Input and Output, HDMI 4K Input, DXLink Twisted Pair 4K Input and Output Boards as well as Audio Switching Board sets can only be installed in an Enova DGX 100 Series Digital Media Switcher. DGX SC Optical Input and Output Boards can only be installed in Enova DGX 8/16/32/64 Digital Media Switchers.*

Unless noted otherwise, all other boards can be installed in both Enova DGX 100 Series and Enova DGX 8/16/32/64 enclosures. Enova DGX input and output boards and Audio Switching Boards are hot-swappable, i.e., the procedure can be done while the system is powered up (for boards that use fiber optic cable, be sure to read the first Caution in the “Safety” box on page 3).

**NOTE:** All DGX boards EXCEPT the Enova DGX Audio Insert/Extract (AIE) Board are hot-swappable, meaning the procedure can be done while the system is powered up. For boards that use fiber optic cable, be sure to read “Safety Recommendations for Laser Products” below.

### Board Compatibility:

A/V Type	Board Type	Part #	Model	DGX 8/16/32/64	DGX-100 Series (8x8 thru 64x64)	Notes
DVI	Input	FG1058-600	DGX-I-DVI	Yes	Yes	
	Output	FG1058-610	DGX-O-DVI			
HDMI	Input	FG1058-540	DGX-I-HDMI	Yes	Yes	
	Output	FG1058-550	DGX-O-HDMI			
HDMI-4K	Input	FG1061-540	DGX-I-HDMI-4K		Yes	
	Input	FG1061-542	DGX-I-HDMI-4K60			
	Output	FG1061-552	DGX-O-HDMI-4K60			
DXLink Twisted Pair	Input	FG1058-570	DGX-I-DXL	Yes	Yes	1, 2
	Output	FG1058-580	DGX-O-DXL			
DXLink Twisted Pair 4K	Input	FG1061-570	DGX-I-DXL-4K		Yes	1, 2
	Output	FG1061-580	DGX-O-DXL-4K			
DXLink Twisted Pair 4K60	Input	FG1061-572	DGX-I-DXL-4K60		8x8, 16x16, & 32x32	1, 6
	Output	FG1061-582	DGX-O-DXL-4K60			
DXLink Fiber	Input	FG1058-622	DGX-I-DXF-MMD	Yes	Yes	
	Output	FG1058-632	DGX-O-DXF-MMD			
	Input	FG1058-620	DGX-I-DXF-SMD			
	Output	FG1058-630	DGX-O-DXF-SMD			
	Input	FG1058-623	DGX-I-DXF-MMS			
	Output	FG1058-633	DGX-O-DXF-MMS			
	Input	FG1058-621	DGX-I-DXF-SMS			
	Output	FG1058-631	DGX-O-DXF-SMS			
DXLink Fiber 4K60	Input	FG1061-624	DGX-I-DXFP-4K60		8x8, 16x16, & 32x32	1, 6
	Output	FG1061-634	DGX-O-DXFP-4K60			
Epica DGX SC optical	Input	FG1056-505	AVS-EPDGX32-OI-SC	Yes		
	Output	FG1056-510	AVS-EPDGX32-OO-SC			

Dante Audio Switching	Dante Audio Switching Board Set (one each, input and output) for Enova DGX 800/1600/3200	FG1061-832	DGX3200-ASB-DAN (Dante Audio Switching Board Kit for Enova DGX 800/1600/3200)		Yes	3, 4
	Dante Audio Switching Board Set (two each, input and output) for Enova DGX 6400	FG1061-864	DGX6400-ASB-DAN (Dante Audio Switching Board Kit for Enova DGX 6400)			
Analog Audio Switching	Audio Switching Board Set (one each, input and output) for Enova DGX 800/1600	FG1061-716	DGX800/1600-ASB (Enova DGX 800/1600 AUD SWITCH BOARD KIT)		Yes	3, 4
	Audio Switching Board Set (one each, input and output) for Enova DGX 3200	FG1061-732	DGX3200-ASB (Enova DGX 3200 AUD SWITCH BOARD KIT)			
	Audio Switching Board Set (two each, input and output) for Enova DGX 6400	FG1061-764	DGX6400-ASB (Enova DGX 6400 AUD SWITCH BOARD KIT)			
Audio Insert/Extract	Audio Insert/Extract (Expansion)	FG1058-705	DGX-AIE	Yes	Yes	3, 4, 5

**NOTES:**

1. When upgrading or replacing these board, the enclosure's firmware must be upgraded via the KIT file provided on your switcher's product page at [www.amx.com](http://www.amx.com) BEFORE inserting the boards.
2. Before connecting a Solecis Digital Switcher to a DXLink Twisted Pair Input Board in an Enova DGX 100 Series Digital Media Switcher, both the Solecis unit and all DXLink Twisted Pair boards must be upgraded with the latest available firmware versions. Solecis units must be upgraded before connecting a unit to an upgraded input board.
3. Audio Switching Boards, Dante Audio Switching Boards, and Audio Insert/Extract Boards are not compatible. Do not install mixed types of expansion boards in the same enclosure. If two types of boards are present, the audio subsystem is disabled.
4. Audio boards can only be installed in expansion slots. All enclosures except the DGX 6400 have one specific input and output expansion slots available for Audio Boards. The Enova DGX 6400 has two specific input and output slots available. In the DGX 6400 enclosure, Audio Input Boards must be installed directly above standard Input Boards in left and right slots, and Output Boards must be installed directly below standard Output Boards in left and right slots.
5. The Enova DGX Audio Insert Extract (AIE) Board is NOT hot-swappable.
6. When installing DXLink 4K60 boards in DGX 100-Series enclosures manufactured before 9/2020, additional EMI shielding may be required. See the Hardware Reference Manual for more information.

## Procedure Overview

**IMPORTANT:** Adding or replacing boards should be done only by personnel trained to handle ESD sensitive parts and assemblies.



**ESD WARNING:** To avoid ESD (Electrostatic Discharge) damage to sensitive components, make sure you are properly grounded before touching any internal Enova DGX materials. Use an ESD wristband and cord with an alligator clip attached to a good ground source.

### Items Required

1. Enova DGX (or compatible) board(s)
2. Phillips #1 screwdriver
3. ESD wristband and cord with alligator clip
4. PC with NetLinx Studio (or another terminal emulation program) and a null modem serial cable (RS-232)

## Safety Recommendations for Laser Products

**WARNING:** DXLink Fiber Boards use a Class 1 laser product to send signals. While the Class 1 category indicates that the invisible laser used is safe, we recommend avoiding direct eye exposure when using any optical fiber product (see the OSHA directive referenced in your product's manual).

**CAUTION:** Safety recommendations for laser products include applying power last. If instead of powering down during the board replacement procedure, you decide to take advantage of the Epica DGX SC Optical Board's ability to hot-swap, be sure that you follow the rest of the laser safety recommendations here and in the instructions when replacing an Epica DGX SC Optical board.

**CAUTION:** Use of controls or adjustments or performance of procedures other than those specified herein may result in hazardous radiation exposure.

**IMPORTANT:** No user serviceable parts are included inside Enova DGX enclosures; service should be done only by qualified personnel.

Exercise caution when installing DXLink Fiber and SC Optical Boards to avoid direct eye exposure to invisible laser radiation. Follow the recommendations below whenever installing or working with Enova DGX optical fiber products.

- Be sure to apply the power only after all fiber connections are made and no fiber ends are exposed.
- *Do not remove* dust plugs from optical/fiber connectors or the dust caps from the fiber cables until establishing connections; avoid direct eye exposure.
- Make sure all cables, including fiber cables, are correctly connected and/or terminated.
- Before you unplug a fiber cable on an input board, disconnect the power on the Transmitter that is connected to the input.
- Before you unplug a fiber cable on an output board, disconnect the switch for that output connector.

## Adding or Replacing a Board

**IMPORTANT:** When replacing a board, be sure to install the new board in the same slot that held the original board to make sure the switching commands are correct.

All Enova DGX 100 Series Switchers are configured to accommodate a full enclosure's worth of boards and do not require modification to the configuration file when a board is added. In rare cases the following may apply to Enova DGX 8/16/ 32/64 enclosures – if you cannot execute switches with the new board after it has been installed, the configuration file may need to be updated; see "Board Troubleshooting" on page 7.

**CAUTION:** Cable management bars must not be used as handles to remove or install boards.

In the following procedure, read each step entirely. The steps include helpful tips to avoid damage to the enclosure's internal cables and connectors.

### Removing and Replacing an Enova DGX Board

1. Optional – If the board being replaced has custom settings that have not been saved, save them now.
  - **Enova DGX 100 Series** – Use the System Configuration interface (see the *Hardware Reference Manual*).
  - **Enova DGX 8 /16/ 32 /64** – Use DGX Configuration Software (available at [www.amx.com](http://www.amx.com)).
2. AIE Boards only – The enclosure *must* be powered down before proceeding.
3. **Optional** – For SC Optical Boards, we recommend unplugging the AC power cords from both of the power supplies (be sure to read the **Cautions** at the top of this page).
4. **Enova DGX 32/3200 only** – Loosen the captive screw on each end of the connector numbering plate above the boards and set the plate aside (FIG. 1):

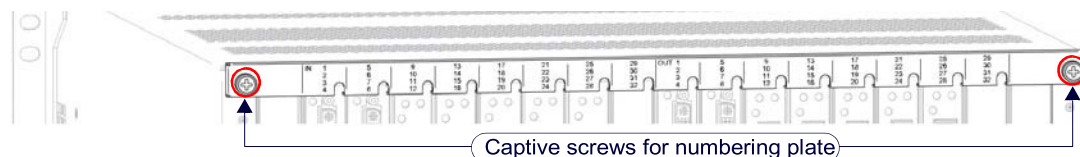

**FIG. 1** Enova DGX 32/3200 only - Two captive screws hold numbering plate above boards

5. If applicable – Label and disconnect all cables on the board being replaced. If cables from adjoining boards obstruct access, label and disconnect them as necessary.  
 If the system is not powered down:
  - **For disconnecting a DGX SC Optical Input Board** – Before disconnecting the fiber cables, disconnect the power on the Transmitters that are connected to the inputs.
  - **For disconnecting a DGX SC Optical Output Board** – Before disconnecting the fiber cables, disconnect the switches for those output connectors.

**IMPORTANT:** *If for any reason you need to reinsert a board back into the same slot, be sure to allow at least 15 seconds between removal and reinsertion to allow time for the board to power up.*
6. **Remove blank board plate** – Remove the screw that holds the board plate in place (for the Enova DGX 8/16/64 and Enova DGX 800/1600/6400, see FIG. 2; for the Enova DGX 32/3200, see FIG. 3).  
 Pull the plate out of the board slot opening (the tab on the end of the board plate fits in a slot near where the ejector handle would otherwise go). The plate consists of an aluminum sleeve with a black metal piece, which slides in and out of the sleeve, and an EMI (Electromagnetic Interference) gasket.  
 - Or -  
**Remove current board** – Remove the pan head screw that holds the board in place (for the Enova DGX 8/16/64 and Enova DGX 800/1600/6400, see FIG. 2; for the Enova DGX 32/3200, see FIG. 3).  
 Push the board's extractor handle as far as it will go (about a 45° angle). With the handle extended, carefully pull the board straight out of the board slot. Place board in an ESD approved static shield bag and set aside.

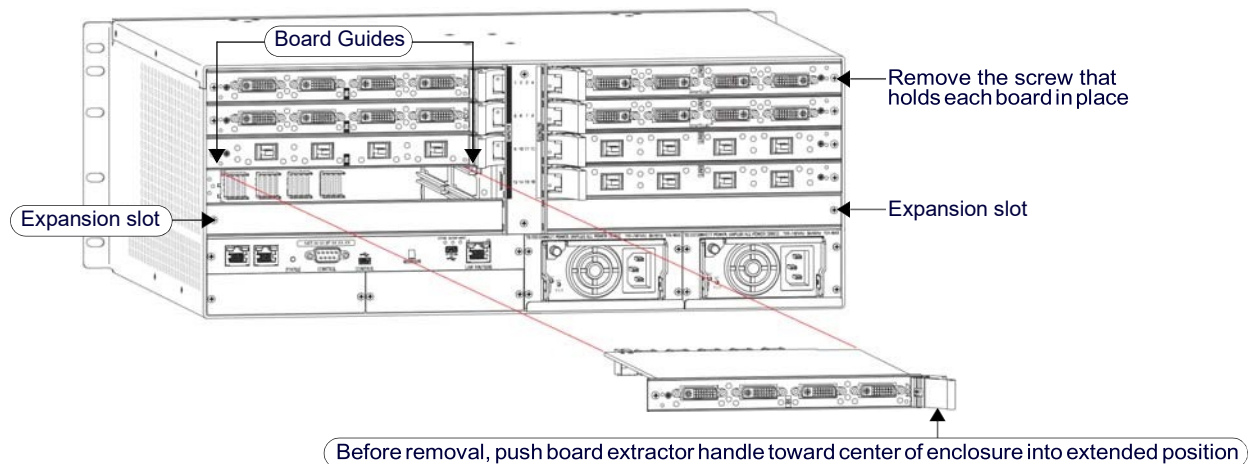

**FIG. 2** Horizontal boards - Remove screw, push board extractor handle right (input) or left (output), pull board straight out

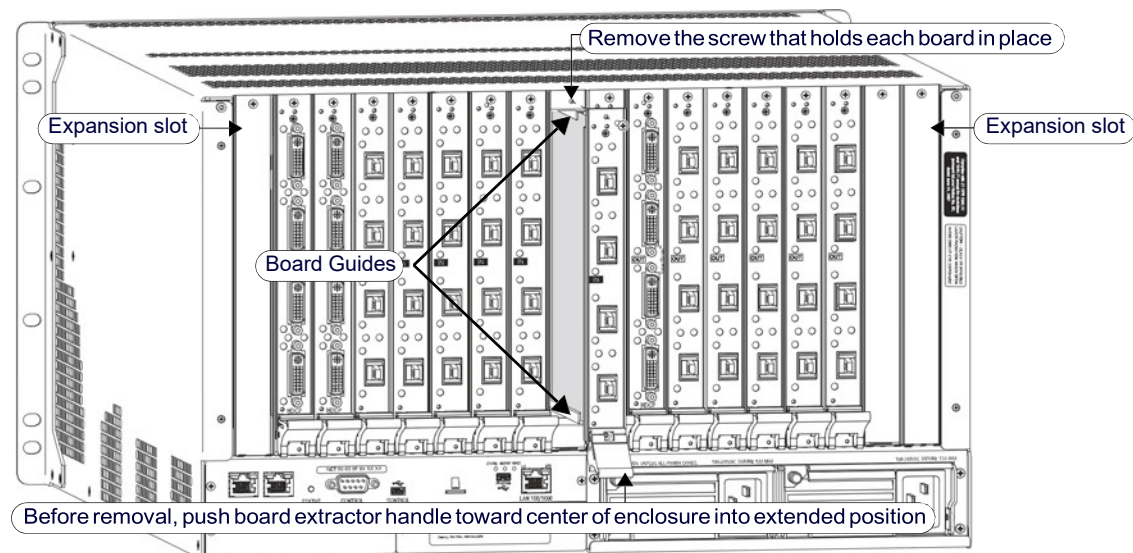

**FIG. 3** Vertical boards - Remove screw, push board extractor handle down, and then pull board straight out

- CAUTION:** *Each Enova DGX board has an EMI gasket along one edge of the faceplate. Handle the boards carefully to avoid dislodging or damaging the gasket on the board being installed and the gasket on the adjacent board or blank plate.*
- CAUTION:** *For DXLink Fiber and SC Optical Boards, do not remove dust plugs from fiber connectors until Step 15.*

7. **Audio Switching Boards only** – *These boards can only be installed in expansion board slots (FIG. 2 and FIG. 3).* For the Enova DGX 6400, information on board slot restrictions are provided in the Caution on page 2.
8. **Audio Insert/Extract Board(s) only** – For information on setting the DIP switches, see page 6 (this is the only way to configure the insert/ extract functionality). Flip the DIP switch for each connector that needs its setting changed. We recommend writing down the setting for each connector to make verifying correct audio switching behavior easier in Step 18. *These boards can only be installed in expansion board slots (FIG. 2 and FIG. 3).*

**IMPORTANT:** *Unused AIE connectors should remain in or be returned to default settings (Enable/Extract).*

9. **Install horizontal boards** – With the board's extractor handle in the extended (unlocked) position, line up the board's edges on the board guides that are along the left and right of the board slot (FIG. 2). Note that input boards have board guides at the top of the slot and board guides for the output boards are at the bottom of the slot due to their reversed orientation in the enclosure.

- Or -

**Install vertical boards** – With the board's extractor handle in the extended (unlocked) position, line up the board's edges on the board guides that are along the top and bottom of the board slot (FIG. 3).

10. Begin pushing the board into the slot until the extractor handle starts to engage the metal extractor plate (the extractor handle moves into its folded position). When the extractor handle starts to lift, flip the handle toward the center of the board until it snaps into its folded (locked) position, which firmly seats the board.
11. Fasten the screw (which was removed in Step 6) that holds the board in place. This screw *must* be tightened securely before connectors are attached in Step 15.
12. If the enclosure was powered down – Plug the AC power cords back into the power supplies.
13. Verify that the system recognizes the board. (See the Verify Board Power Up section for your switcher on page 7 or page 8.)
14. Optional for systems with SC Optical Boards – Power down the enclosure again.

**NOTE:** *If using a cable management bar, tie the cable to the cable management bar far enough below the connector to allow for the manufacturer's recommended bend radius. The bend radius for AMX SC terminated fiber cables is 2 inches (5 cm).*

15. Attach cables to the board's connectors and reconnect any other cables that were disconnected in Step 5 (if applicable – tie cables to the cable management bars).
  - For Enova DGX 800/1600/3200 systems with ASB Boards – Attach HSSI cable from SMA port on ASB Input Board to SMA port on ASB Output Board.

*If the enclosure is not powered down:*

- **For connecting an SC Optical Input Board** – Avoid direct eye exposure as you (a) remove the dust plugs from the fiber connectors on the board, (b) remove the dust caps from the fiber cables, (c) establish the connections, and (d) apply power to the Transmitters that are connected to the inputs.
- **For connecting an SC Optical Output Board** – Avoid direct eye exposure as you (a) remove the dust plugs from the connectors on the board, (b) remove the dust caps from the fiber cables, and (c) establish the connections.

*If the enclosure was powered down – Reapply power.*

16. **Optional** – If you saved any custom board settings to load to the board, load them now.
  - **Enova DGX 100 Series** – Use the System Configuration interface (see the *Hardware Reference Manual*).
  - **Enova DGX 8 /16/ 32 /64** – Use DGX Configuration Software (available at [www.amx.com](http://www.amx.com)).
17. Execute a test switch using a connection on the new board to be sure that video is present at the destination (Control Panel: press Function Key, Select Key, Input Key, Output Key, and Take Key).
  - Additional testing for **Audio Insert/ Extract Board** functionality:
    - Insert function** – If DIP switch for audio connector is set to insert, the video signal from the corresponding video input or output will carry the inserted audio; check that the inserted audio is present with the display.
    - Extract function** – If DIP switch for audio connector is set to extract, the audio will be extracted from the corresponding video input or output signal; check the auxiliary or supplemental audio equipment involved to be sure the extracted audio signal is present where expected. If the test switch does not work, see "Board Troubleshooting" on page 7.

**IMPORTANT:** *Unused AIE connectors should remain in or be returned to default settings (Enable/Extract).*

18. **Enova DGX 32 /3200 only** – Replace the connector numbering plate that was removed in Step 4.

**IMPORTANT:** *If for any reason a board slot is left empty, be sure to attach a blank plate to cover it.*

## Additional Video Board Information

Additional information on video boards can be found in the specific product's manual, including:

- Information on cabling and specifications.
- Information on board configuration using the System Configuration interface (for Enova DGX 100 Series enclosures) or DGX Configuration Software (for Enova DGX 8/16/32/64 enclosures).
- Information on system setup with DXLink Transmitters and Receivers.
- Information on system setup with DGX Fiber Modules for SC Optical Boards.

Additional information on Enclosures is available in the following Manuals which can be found on the product's pages at [www.amx.com](http://www.amx.com):

- **The Hardware Reference Manual** – Enova DGX 100 Series Digital Media Switchers (which includes information on the System Configuration interface).
- **The Instruction Manual** – Enova DGX 8/16/32/64 Digital Media Switchers and DGX Configuration Software.

## Setting Audio Insert/Extract Board(s)

**NOTE:** For wiring information on Audio Insert/Extract Boards, see the Hardware Reference Manual – Enova DGX 100 Series Digital Media Switchers or the Instruction Manual – Enova DGX 8/16/32/64 Digital Media Switchers at [www.amx.com](http://www.amx.com).

The individual connectors on the AIE Board can be configured to either “insert audio onto” or “extract audio from” the signal routed on numerically corresponding standard inputs or outputs. The configuration process, i.e., setting the DIP switches, *must be done* before the board is installed in the enclosure. Each connector also has a switch to enable or disable the insert/extract function. Each board has two DIP switches per audio connector with the corresponding connector number displayed vertically between the switches (labeled “Channel Setting” – see yellow rectangle in FIG. 4.)

Before installing an AIE Board, set each connector as desired:

- **“Enable–Disable” DIP Switches (left side):**  
To enable, flip left. Enable must be selected for the insert/extract function to work. To disable, flip right. Disable turns off the extract/insert function.
- **“Extract–Insert” DIP Switches (right side):**  
To extract audio, flip left. The audio connector will pull the embedded audio signal off the corresponding input or output connector's signal.  
To insert audio, flip right. The audio connector will insert the connected audio signal onto the corresponding input or output connector's signal.

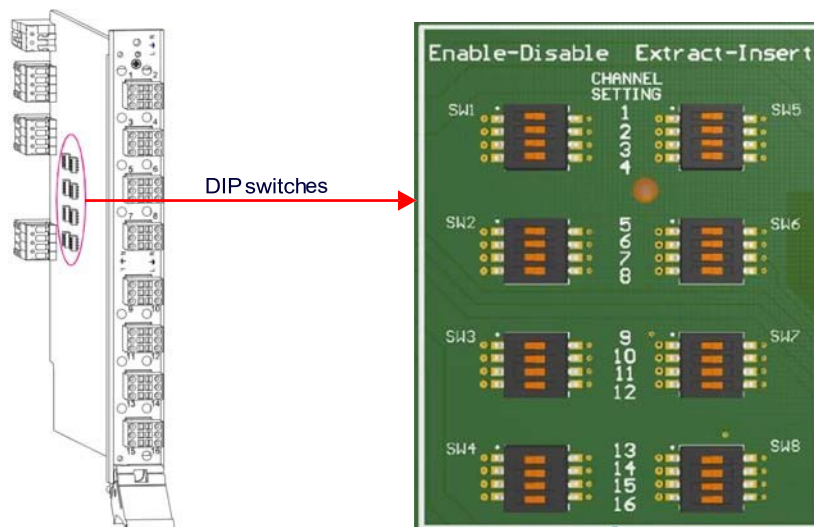

**FIG. 4** Flip DIP switches on left to enable or disable the extract/insert function and on right to set function

**IMPORTANT:** Unused AIE connectors should remain in or be returned to default settings (Enable/Extract).

**NOTE:** For AIE boards (except Enova DGX 64/6400), the audio signals are routed on the first sixteen numerically corresponding standard inputs or outputs, depending on whether the expansion slot is on the left (inputs) or the right (outputs).

- **Enova DGX 8 /800** – AIE connectors 9-16 are inoperable.
- **Enova DGX 32/3200** – AIE boards will not work in conjunction with standard input and output connectors 17-32 (on boards in the last four slots on either side).
- **Enova DGX 16/64/1600/6400** – with full I/O and AIE board sets, the number of AIE connectors matches the number of input and output connectors.

## Board Troubleshooting

**IMPORTANT:** If for any reason, you remove a board and then reinstall the board in the same slot, be sure to allow at least 15 seconds in between removal and reinsertion, or the board may not power up correctly.

### Verify Board Power Up (Enova DGX 8/16/32/64)

#### Verifying That All I/O Boards Have Been Powered Up After Hot-swapping

1. Attach a PC to the serial port on the enclosure with an RS-232 null modem cable. Pinout for PC to enclosure: 5 GND to 5 GND, 2 RXD to 3 TXD, and 3 TXD to 2 RXD.
2. Open NetLinx Studio (v4.0 or later).
3. Select Tools/Terminal Session (if using another terminal emulation program, be sure to set the COM port and communication settings per the next sub-step). The Terminal Window Communication Settings dialog box opens.
4. Set COM port and Serial Settings  
 Default settings:  
 Enova DGX 8/16/32/64: 9600 Baud / 8 / None / 1 / None;  
 Enova DGX 100 Series: 115200 Baud / 8 / None / 1 / None;  
 click OK.
5. Enter the command `~scri4v3!` and press Enter.
6. Check to be sure the new board is included in the input or output boards list (FIG. 5). Audio boards (either type) will be listed under "expansion boards." If the board is not in the list, re-seat the board and enter the command again.

```

Terminal -<Online: COM19600>
~scri4v3!
[4:Hardware Boards] detected
[switching drivers] count = 1
(Scroll past switching drivers information to view board information.)
[input boards] count = 8
[board 1] c0e0
[board 2] c0e0
[board 3] c0e0
[board 4] c0e0
[board 5] c0e0
[board 6] c0e0
[board 7] c0e0
[board 8] c0e0
    
```

Number of boards listed **must** match the actual number of boards in the enclosure

FIG. 5 Splash screen showing boards in the system (Enova DGX 32 example with 8 input boards)

7. Enter the command `~scri6v3!` and verify that none of the boards report an "alarm" (FIG. 6):

```

Terminal -<Online: COM19600>
~scri6v3!
[io board 13 pol 1] good
[status flags] 0x0
[voltage] 4.93v
[current] 1.33a
[temp] 29.2c
[io board 14 pol 1] alarm
[status flags] 0x2
[voltage] 0.00v
[current] 0.35a
[temp] 0.0c
[io board 15 pol 1] good
[status flags] 0x0
[voltage] 4.96v
    
```

Alarm notification for I/O board 14

FIG. 6 Terminal information showing an "alarm" for a board that has not powered up correctly

**IMPORTANT:** If an alarm is reported in the splash screen, the I/O board must be manually powered back up using the `DGX_SHELL` command `power ON BCPUs`, where `x` is the slot number of the board (for additional information on `DGX_SHELL` commands, see the manual for your product at [www.amx.com](http://www.amx.com)).

8. Complete a test switch.

## Verifying Board Power Up (Enova DGX 100 Series)

To verify that all I/O boards have been powered up after hot-swapping, navigate to the System Configuration interface's Status page (Switcher/Status) and verify that none of the boards report an alarm (see FIG. 7 below).

After the switcher has been fully setup (see the *Hardware Reference Manual*), the System Configuration interface is accessible via web browser by entering the switcher's IP Address (retrieve IP Address from the Control Panel, navigate *Setup Options / Master Info / IP Address*).

The screenshot displays the 'Status' page of the Enova DGX Switcher Configuration interface. At the top, there are fields for 'Username' and 'Password' with a 'Login' button. Below this, navigation tabs for 'Switching', 'Configuration', and 'Status' are visible, with 'Status' being the active tab. A 'System Auto-Setup' checkbox is checked, and there are buttons for 'Save Upgrade Log' and 'Refresh'. Three alarm indicators are shown: 'Fan Alarm: OK' (green), 'Power Alarm: FAIL' (red), and 'Temperature Alarm: OK' (green). A red arrow points from the 'Power Alarm: FAIL' indicator to the 'Power Alarm' column in the 'Input Boards' table. The 'Input Boards' table has two rows: Slot 1 is 'FAIL' (red triangle) and Slot 2 is 'OK' (green triangle). The 'Output Boards' table has two rows, both 'OK'. The 'Input Expansion Audio Boards' table has one row 'OK'. The 'Output Expansion Audio Boards' table has one row 'FAIL' (red triangle). A red arrow points from the 'FAIL' indicator in the 'Output Expansion Audio Boards' table to the 'Power Alarm' column in the 'Input Boards' table. At the bottom, there are 'Switcher Setup' buttons: 'Save', 'Load', and 'Group Restore to Default'. A copyright notice 'Copyright © 2008-2015 AMX, LLC' is at the bottom right.

Power Alarm notification

Alarm notification on input board 1 (BCPU1)

Normal indicator on input board 2 (BCPU2)

Normal indicator on expansion input board

Alarm notification on expansion output board

FIG. 7 Status information showing board OK and FAIL states

**NOTE:** Immediate recovery from Power FAIL state may occur after Reboot of indicated board. If reboot is ineffective, remove and re-install the indicated board.



## Confirming Board Versions

Enova DGX enclosures and boards typically ship with the latest firmware available. If the firmware on any board installed in the enclosure does not match the firmware version the enclosure expects, a firmware mismatch occurs. To resolve a firmware mismatch, the latest available firmware .kit file (which contains firmware for both boards and enclosure) must be sent to the enclosure.

1. Launch NetLinx Studio and connect to the DGX Controller.
2. Open the OnLine Tree tab, right-click in the Workspace Bar field and select Refresh System Online Tree.
3. Expand the 5002 device and confirm compatible board versions (or mismatch).

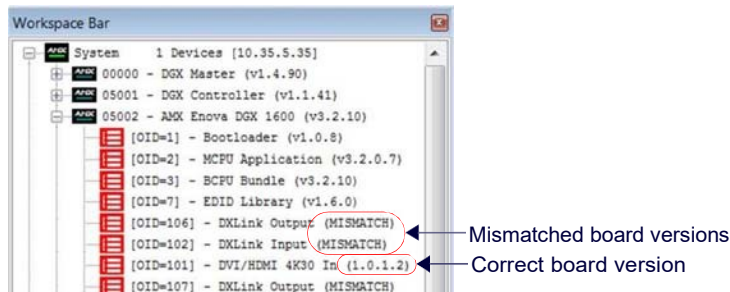

FIG. 8 NetLinx Studio - Workspace Bar

4. If a mismatch is present, send the latest firmware .kit file to the enclosure.

## Sending a Firmware .kit File to the Enclosure

1. Navigate to your system's product page and download and unzip the "Enova DGX 100 Series Enclosure Firmware" .zip file.
2. Launch NetLinx Studio and navigate to the OnLine Tree.
3. Right-click on the 5002 device and select Firmware Transfer.
4. Click the Browse button and navigate to the downloaded file target directory.
5. Select the file for the Enova DG X from the Files list. Click Send.
  - a. During the switcher's upgrade process, the 5002 device stays offline and the control panel and System Configuration interface (System/Devices/Switcher Update Status) display upgrade status messages.
  - b. Once the upgrade is complete, the 5002 device comes back online and the System Configuration interface upgrade status reports that the system is rebooting.

## Problems with Executing Switches

If you cannot execute switches with the new board after it has been installed, verify the system's configuration by entering `~scri5v3!` in a terminal emulation program (FIG. 9).

This command retrieves information on the crosspoint size of the virtual matrices (VMs), which determine the routing of signals. Enova DGX 100 Series Switchers contain three VMs, and Enova DGX 8/16/32/64 Switchers contain two VMs.

**IMPORTANT:** All Enova 100 Series Switchers ship with a standard configuration which handles a "full" crosspoint; therefore, all enclosures automatically accept additional boards to fill to their maximum I/O size.

**NOTE:** The configuration file is automatically generated by the system based on its hardware – input and output boards, expansion boards, front control panel, CPU, etc. If boards are added during runtime, they are immediately added to the system's configuration.

## Checking Crosspoint Size (Enova DGX 8/16/32/64)

From the factory, the automatically generated configuration contains two VMs: VM 0 = all signals and VM 1 = video signals.

The crosspoint size for each VM is set at a full 8x8 for an Enova DGX 8 (two input and two output boards), 16x16 for an Enova DGX 16 (four input and four output boards), 32x32 for an Enova DGX 32 (eight input and eight output boards), and 64x64 for an Enova DGX 64 (sixteen input and sixteen output boards).

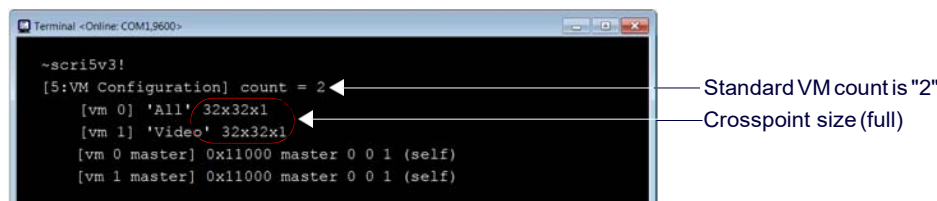

FIG. 9 Splash screen information indicating a standard configuration file for an Enova DGX 32

If the crosspoint size is less than full (e.g., 24x24 in an Enova DGX 32) and the new board increases the size past the size indicated on the splash screen, then the system was customized for a non-standard crosspoint size that is not large enough to accommodate the new board.

The configuration file *must be* updated before the new board will work (see “Updating the Configuration File” below). If the crosspoint size is large enough to accommodate the new board and you still cannot execute switches, contact technical support (see below).

### Updating the Configuration File (Enova DGX 8/16/32/64)

If the configuration file requires updating (as explained in the previous section), read both choices listed to determine how to proceed.

- If a system’s configuration file has not been modified since shipment from the factory, enter `~def!` in a terminal emulation program to establish a default configuration of 8x8, 16x16, 32x32, or 64x64 with 2 VMs.
- If the original configuration file has been modified in any way (e.g., local presets were added), we recommend sending a copy of the modified file to technical support, so they can add support for the board change to the modified file before you download the file to the CPU (downloading requires XNConnect software which is available at [www.amx.com](http://www.amx.com)).

## Technical Support

If this *Technical Support Guide* has not satisfactorily answered your questions regarding Enova DGX board replacement on an Enova DGX 100 Series or Enova DGX 8/16/32/64 Switcher, please contact your AMX representative or technical support. Have the product’s serial number ready (it is normally located on the rear of the enclosure).

We recommend recording the product’s serial number in an easily accessible location.

**HARMAN Technical Support Contact Number: (844) 776-4899**



Last Revised: 2021-03-19

© 2021 Harman. All rights reserved. Modero, AMX, AV FOR AN IT WORLD, HARMAN, and their respective logos are registered trademarks of HARMAN. Oracle, Java and any other company or brand name referenced may be trademarks/registered trademarks of their respective companies. AMX does not assume responsibility for errors or omissions. AMX also reserves the right to alter specifications without prior notice at any time. The AMX Warranty and Return Policy and related documents can be viewed/downloaded at [www.amx.com](http://www.amx.com).  
3000 RESEARCH DRIVE, RICHARDSON, TX 75082 AMX.com | 800.222.0193 | 469.624.8000 | +1.469.624.7400 | fax 469.624.7153  
AMX (UK) LTD, AMX by HARMAN - Unit C, Auster Road, Clifton Moor, York, YO304GD United Kingdom | +44 1904-343-100 | [www.amx.com/eu/](http://www.amx.com/eu/)

93-1058-050  
REV: P

