

SONY

Crystal LED VERONA

for Virtual Production

ZRD-VP15EB/ZRD-VP23EB
ZRD-VP15EM/ZRD-VP23EM



Crystal LED VERONA



Ideally suited to demanding virtual production applications, our latest-generation VERONA modular Crystal LED video walls delivers breathtaking images with truly impressive brightness and clarity.

VERONA's extraordinary black levels, low reflection, high brightness, wide color gamut and high refresh rate, plus installation-friendly features let content creators compose immersive and realistic visual experiences on any scale.

Industry-leading innovation in virtual production



As a global leader in motion picture production, creative technology and entertainment, by working closely with the industry and creative leaders, Sony understands the exciting possibilities as well as the technical challenges of virtual production.

This unique combination of industry insight and technological innovation has enabled us to create VERONA – the most advanced expression yet of Crystal LED technology, giving content creators and performers a uniquely expressive canvas for the next generation of virtual production.

Virtual real: exceptional picture quality in demanding production applications

Crystal LED VERONA is a compelling choice for virtual production. The extraordinary black levels, low reflection, high brightness, wide color gamut and high refresh rate of Crystal LED lets content creators realize lifelike digital backdrops, dramatically simplifying the creation of complex multi-element shots in-camera without the need for live actors to perform in front of green screens.

Industry-leading black levels with reduced reflections and glare

Achieving deep, realistic black levels is one of the most persistent challenges in virtual production workflow. Incident light from other sources falling on the LED wall can cause inadequate black levels in virtual backgrounds, requiring costly correction in post production. VERONA utilizes Sony's newly developed Deep Black and Anti-Reflection Surface Technologies to achieve unmatched black levels – allowing incredibly natural, realistic mixing of real and virtual elements.

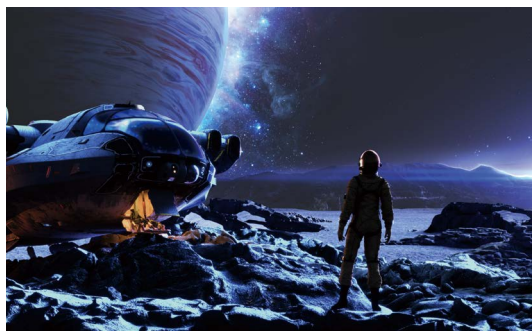

Conventional LED



VERONA

Deep Black and Anti-Reflection Surface Technology

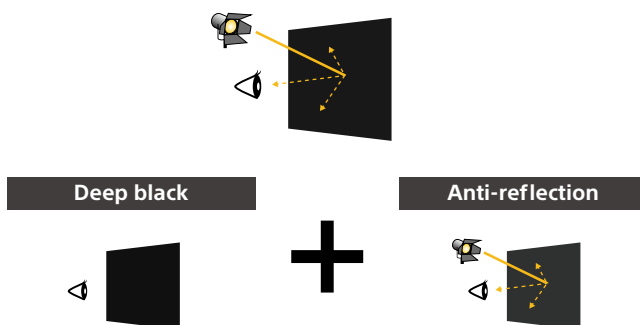

Leveraging a long history in display technology expertise as well as close relationships with industry-leading material manufactures, and after years of material selection, trials, and evaluation, Sony engineers have developed a surface technology that achieves both extraordinary black levels and anti-reflection while maintaining high brightness and wide color gamut.

High brightness and wide, cinematic color gamut

VERONA is ideally suited to the demands of virtual production, with an extremely high display brightness of 1,500 cd/m² complemented by accurate reproduction of over 98% of the DCI-P3 color gamut.

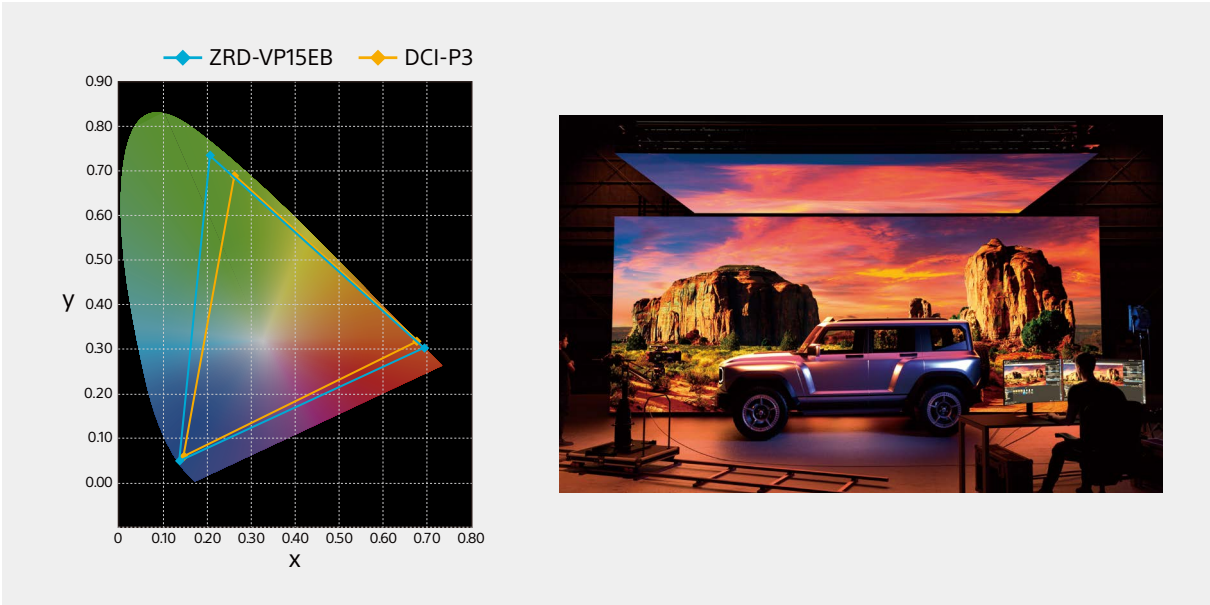

High refresh rate reduces scanline artifacts

If the refresh rate of an LED display is too low, it can cause flickering and distracting scanline artifacts that are particularly noticeable with today's high frame rate cameras used for virtual production. VERONA employs high performance LED driver ICs (Integrated Circuits) capable of extremely high refresh rates up to 7,680Hz – significantly greater than other commercially available LED wall solutions.

Scan line artifacts occur when shooting from a camera due to the low refresh rate LED

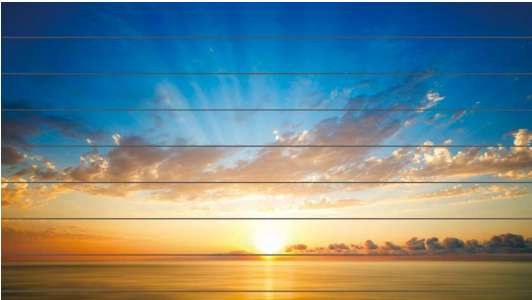

Conventional LED

VERONA goes up to 7,680Hz and without visible scan lines when shooting from a camera



VERONA

Installation flexibility

VERONA gives system integrators and rental specialists exceptional installation freedom. The modular LED panels are easy to install without needing special skills or costly jigs and other complex equipment.

◆ Quick, easy construction

Popular with the virtual production rental industry, the self-stacking cabinet's square 1:1 proportion simplifies rapid LED wall assembly.

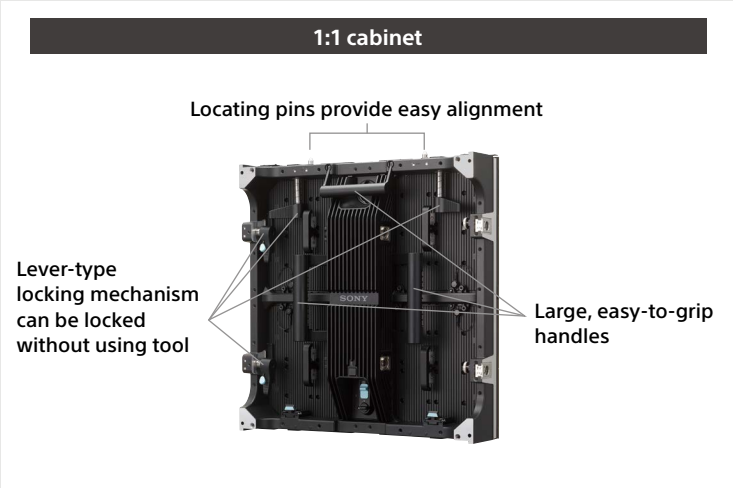

◆ Supports various installation forms

VERONA gives installers exceptional flexibility in building LED walls of virtually any scale and shape, including very large stacks and curved surfaces.

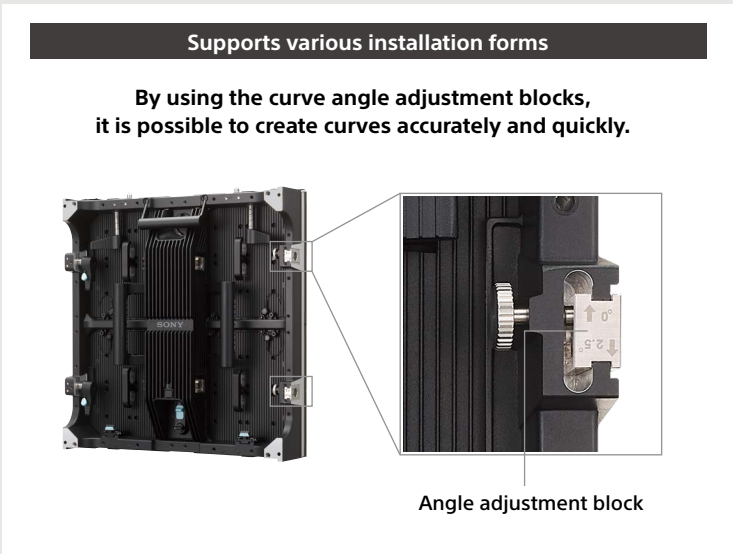

◆ Precise Z-axis adjustment

Easy Z-axis adjustment allows fine alignment of individual cabinets, ensuring that the LED wall surface is extremely flat to eliminate visible lines when shooting from an angle.

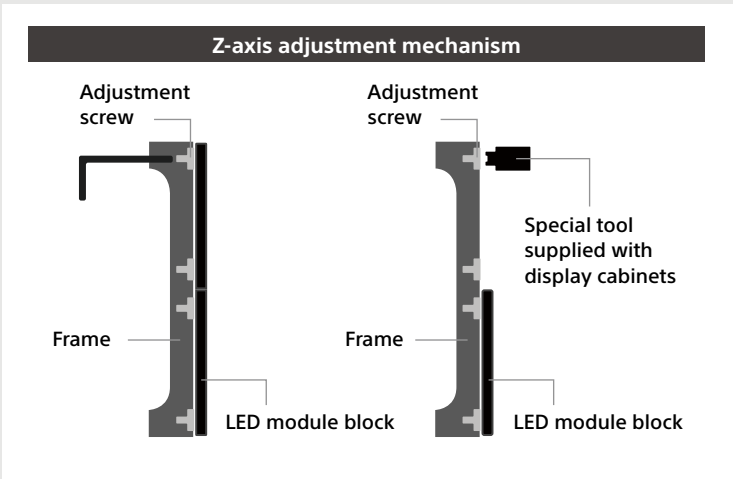

Installation flexibility

◆ Reduced LED module damage

VERONA features protection measures to minimize the risks of costly accidental damage when individual cabinets are joined together during LED wall construction. In addition each module features a protective surface coating layer that safeguards LEDs from being dislodged or damaged.

Surface protection

Conventional LED

As the LED package is only mounted on the surface, it is easy to remove.

VERONA

Since the surface is flat, it is difficult to remove the LED.

Protection mechanisms

Edge Protection

Edge protection plate automatically slides in when two cabinets are combined to avoid top and bottom from hitting together.

Groove for sliding contact

The pin slides on the groove and falls into the hole to avoid sides of the cabinets from rubbing together.

Quick, easy routine maintenance

Costly downtime is a luxury that no virtual production facility can afford. VERONA is designed for easy maintenance, cutting pressure on technical crews with time-saving features for simple maintenance.

Quick module swaps

Individual LED modules can be easily exchanged with access from the front and back of the cabinet.



Status light

A status indicator light on the back of each module makes it simple to identify any units that need exchanging.



Detachable power unit

Each module's power unit can be easily detached via a simple locking knob, with no special tools needed.



Energy efficient design

Electrical power consumption is a significant contributor to everyday running costs for any virtual production facility. VERONA combines energy-efficient super fine LED circuits with advanced Sony power control technology, reducing consumption by up to 38%* compared to conventional LED walls.

* As power per unit brightness.

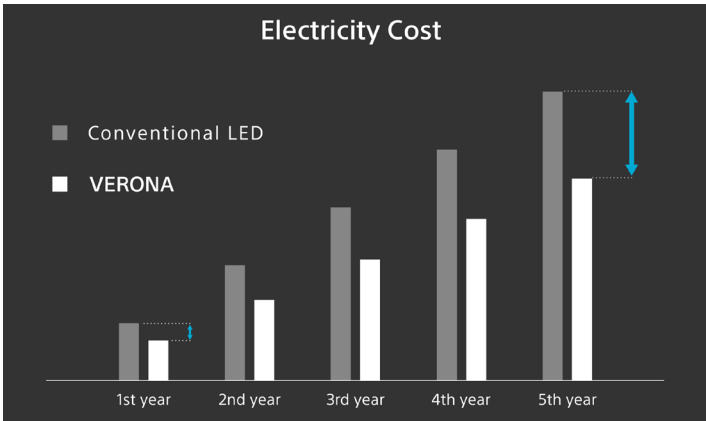

Workflow friendly

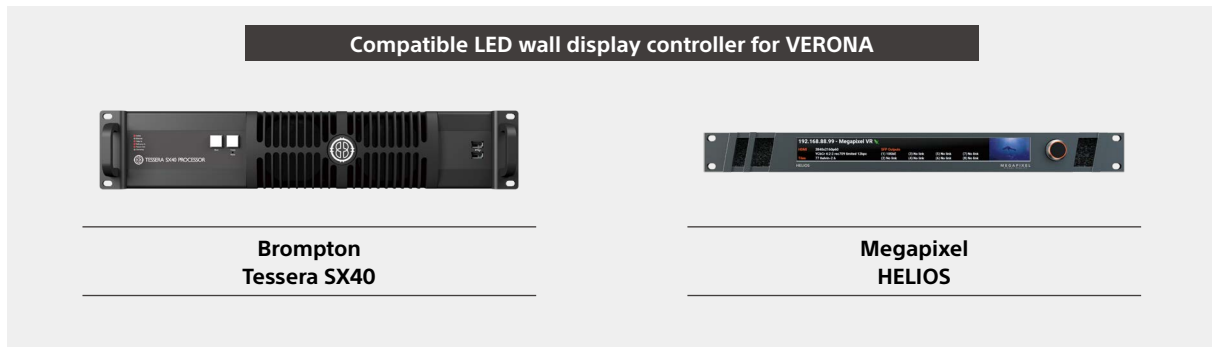

Crystal LED is designed to fit smoothly and efficiently into today's virtual production workflow. VERONA is available in versions that are fully compatible with leading LED wall display controller companies Brompton and Megapixel, simplifying integration into a wide range of virtual production environments while reducing training requirements. Furthermore, exceptional black levels and consistently accurate color reproduction during shooting means less additional work in post-production.

Display Cabinet



Specifications

Model	ZRD-VP15EB	ZRD-VP23EB	ZRD-VP15EM	ZRD-VP23EM
Supported display controller	Brompton Tesseract SX40		Megapixel HELIOS	
Pixel Pitch	ZRD-VP15EB: 1.56 mm ZRD-VP23EB: 2.31 mm		ZRD-VP15EM: 1.56 mm ZRD-VP23EM: 2.31 mm	
Surface	Deep Black and Anti-Reflection Surface Technology			
Resolution (W x H)	ZRD-VP15EB: 320 x 320 ZRD-VP23EB: 216 x 216		ZRD-VP15EM: 320 x 320 ZRD-VP23EM: 216 x 216	
Brightness (Max.)	1,500 cd/m ²			
Contrast Ratio (0 lx)	More than 1,000,000:1			
Viewing Angle (H/V)	170°/170°			
Color Gamut (BT2020, Δu'v' coverage)	Approx. 88 %			
Color Gamut (DCI-P3, Δu'v' coverage)	Approx. 98 %			
Color Gamut (sRGB, Δu'v' area)	Approx. 151 %			
Refresh Rate	7,680 Hz			
Signal Interface	1 in 1 out (2 x RJ45)			
Operation Temperature	0 °C - 45 °C (32 °F - 113 °F)			
Storage Temperature	-20 °C - 60 °C			
Operation Humidity	20-80 % (No condensation)			
Storage Humidity	20-80 % (No condensation)			
Power Requirements	AC100-240 V, 50/60 Hz			
Power Consumption (Max.)	145 W			
Calibration mode: Off or Overdrive: On	(Per-sqm: 580 W)			
Power Consumption (Calibrated 100% brightness)	108 W	114 W	119 W	125 W
Calibration mode: On	(Per-sqm: 432 W)	(Per-sqm: 456 W)	(Per-sqm: 476 W)	(Per-sqm: 500 W)
Power Consumption (Ave. 30% brightness)	60 W	56 W	62 W	63 W
Calibration mode: On	(Per-sqm: 240 W)	(Per-sqm: 224 W)	(Per-sqm: 248 W)	(Per-sqm: 252 W)
Dimensions (W x H x D)	500 x 500 x 93 mm (19 11/16 x 19 11/16 x 3 21/32 in)			
Mass / Weight	Approx. 10.1 kg (22 lb 4.27 oz) (Per-sqm: Approx. 40.4 kg)			
Max. Self-stacking / Hanging	Max. 14 cabinets (7 m) / Max. 14 cabinets (7 m)			
Application	Indoor			