

V-998-AM LED STROBE

INTRODUCTION

These instructions contain the specifications and information for the V-998-AM Strobe.

Features

- Cost effective and versatile solution to applications requiring visual alerts or strobes
- Wall mounting box included
- 24 Volt Power Supply included

Activation Methods

- 70 Volt amplified speaker signal
- Dry contact closure
- Electronic Message Sign 5V signal
- See Figures 1-3 for Details

Specifications

- **Brightness:** 110 Candela
- **Flash Frequency:** 1 per second (1 Hz)
- **Flash Duration:** < 20 ms
- **Power supply voltage input:** 110 Vac
- **Strobe minimum voltage:** 18 Vdc
- **Strobe maximum voltage:** 30 Vdc
- **DC Current draw:** 90 mA
- **Activation voltage requirements**
 - Electronic message sign**
40µA at 3 Volts
 - 70 Volt audio signal**
70 Volts peak
- **Lens color:** Amber
- **Faceplate cover:** Ivory

Dimensions/Weight

- 5.5"H x 5.0"W x 2.0"D
(13.9cm H x 12.7cm W x 5.08cm D)
- 0.62 lbs. (0.27 kg)



Environment

- **Temperature:** 32 to 104° F (0 to 40° C), Indoor use only
- **Humidity:** 0 to 85% non-precipitating

Precautionary Designations

- **WARNING-To Reduce The Risk Of Fire Or Electric Shock. Do Not Expose This Apparatus To Rain Or Moisture.**
- **AVERTISSEMENT - Afin de réduire les risques d'incendie ou de décharge électrique, évitez d'exposer le système à la pluie ou à l'humidité.**
- **Apparatus shall not be exposed to dripping or splashing and no objects filled with liquids, such as vases, shall be placed on the apparatus.**
- **L'appareil ne doit pas être exposé à des égouttements et éclaboussures et aucun Objet Rempli de liquide, comme vase, ne doit être placé sur l'appareil.**

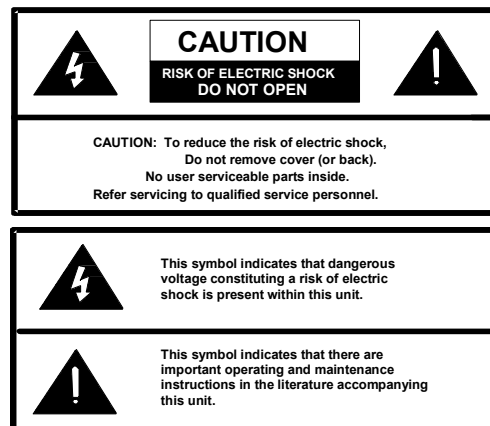

IMPORTANT SAFETY INFORMATION

CONSIGNES DE SÉCURITÉ IMPORTANTES

1. Read these instructions.
Lisez ces instructions.
2. Keep these instructions.
Conservez ces instructions.
3. Heed all warnings.
Respectez tous les avertissements.
4. Follow all instructions.
Suivez toutes les instructions.
5. Do not use this apparatus near water.
Ne pas utiliser cet appareil près de l'eau.
6. Clean only with dry cloth.
Nettoyer avec un chiffon sec.
7. Do not block any ventilation openings. Install in accordance with the manufacturer's instructions.
Ne pas bloquer les ouvertures de ventilation. Installer conformément aux instructions du fabricant.
8. Do not install near any heat sources such as radiators, heat registers, stoves or other apparatus (including amplifiers) that produce heat.
Ne pas installer à proximité de sources de chaleur telles que radiateurs, registres de chaleur, poêles ou autres appareils (y compris les amplificateurs) produisant de la chaleur.
9. Do not defeat the safety purpose of the polarized or grounding-type plug. A polarized plug has two blades with one wider than the other. A grounding type plug has two blades and a third grounding prong. The wide blade and the third prong are provided for your safety. If the provided plug does not fit into your outlet consult an electrician for replacement of the obsolete outlet.
Ne pas contourner le dispositif de sécurité de la fiche polarisée ou de mise à la terre. Une fiche polarisée possède deux lames dont une plus large que l'autre. Une fiche de terre a deux lames et une troisième broche de mise à la terre. La lame large et la troisième broche sont fournies pour votre sécurité. Si la fiche fournie ne rentre pas dans votre prise, veuillez consulter un électricien pour le remplacement de la prise obsolète.
10. Protect the power cord from being walked on or pinched particularly at plugs, convenience receptacles and the point where they exit from the apparatus.
11. Only use attachments/accessories specified by the manufacturer.
N'utilisez que des fixations / accessoires spécifiés par le fabricant.
12. Use only with the cart, stand, tripod, bracket or table specified by the manufacturer or sold with the apparatus. When a cart is used, use caution when moving the cart/apparatus combination to avoid injury from tip-over.

Utilisez uniquement avec le chariot, stand, trépied, support ou table spécifié par le fabricant ou vendu avec l'appareil. Quand un chariot est utilisé, Soyez prudent lorsque vous déplacez l'ensemble chariot / appareil pour éviter des blessures dues au renversement.
13. Unplug this apparatus during lightning storms or when unused for a long period of time.
Débranchez cet appareil pendant les orages ou lorsqu'il n'est pas utilisé pendant une longue période de temps.
14. Refer all servicing to qualified service personnel. Servicing is required when the apparatus has been damaged in any way. Such as when the power supply cord or plug is damaged, liquid has been spilled, objects have fallen into the apparatus or the apparatus has been exposed to rain or moisture and does not operate normally or has been dropped.
Confiez toute réparation à un personnel qualifié. Une réparation est nécessaire lorsque l'appareil a été endommagé de quelque façon. Par exemple lorsque le cordon d'alimentation ou la fiche est endommagé, du liquide a été renversé, si des objets sont tombés dans l'appareil ou le appareil a été exposé à la pluie ou à l'humidité et ne fonctionne pas normalement ou s'il est tombé.

FCC Information

This equipment has been tested and found to comply with the limits for a Class A digital device, pursuant to Part 15 of the FCC Rules. These limits are designed to provide reasonable protection against harmful interference when the equipment is operated in a commercial environment. This equipment generates, uses and can radiate radio frequency energy and if not installed and used in accordance with the instruction manual, may cause harmful interference to radio communications. Operation of this equipment in a residential area may cause harmful interference in which case the user will be required to correct the interference at his own expense.

MOUNTING

A surface mounting box is included with the V-998-AM, or other double gang FD electrical box may be used. Verify depth of electrical box is adequate for mounting. See Figure 4 for surface mounting diagram, or Figure 5 for flush mounting (inwall) diagram.

NOTE: The V-998-AM is not synchronized with other strobes, and therefore must not be installed where the flash from more than one strobe may be seen.

TECHNICAL ASSISTANCE

When calling, have a VOM and a telephone test set available and call from the job site. Call (540) 563-2000 and ask for Technical Support, or visit our website at <https://www.valcom.com>.

WARRANTY

Warranty information may be found on our web site at www.valcom.com/warranty.

Should repairs be necessary, attach a tag to the unit clearly stating company name, address, phone number, contact person, and the nature of the problem. Send the unit to:

**Valcom, Inc.
Repair & Return Dept.
5614 Hollins Road
Roanoke, VA 24019-5056**

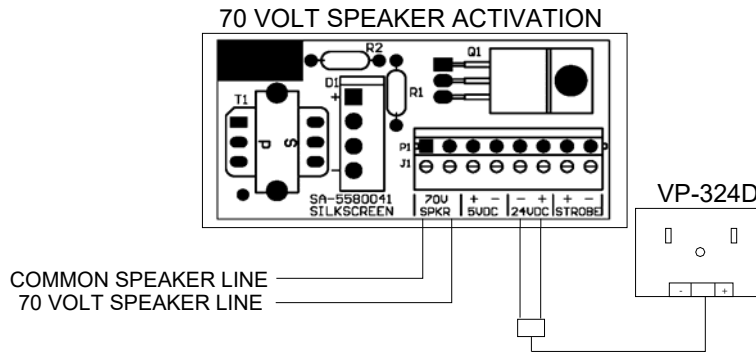

Figure 1

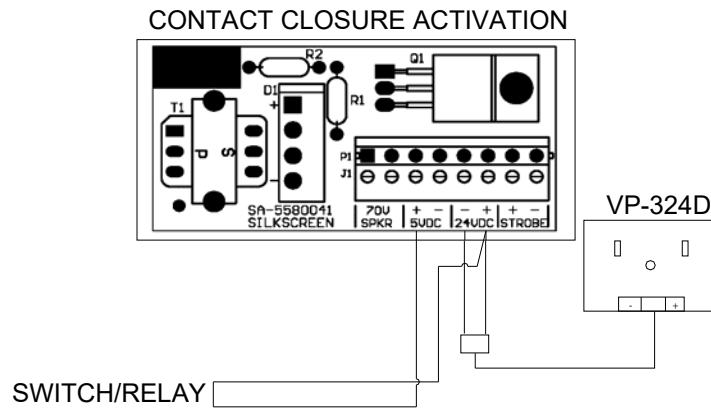

Figure 2

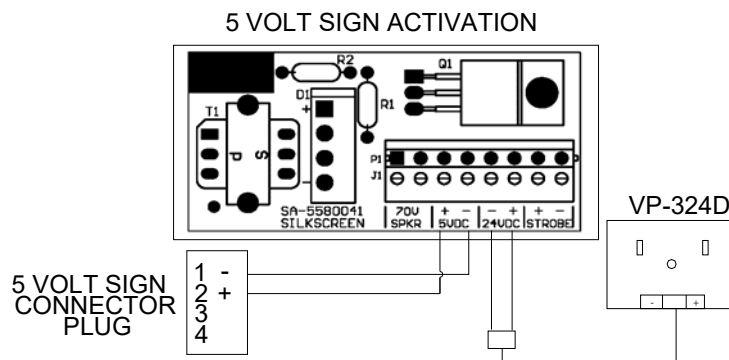

Figure 3

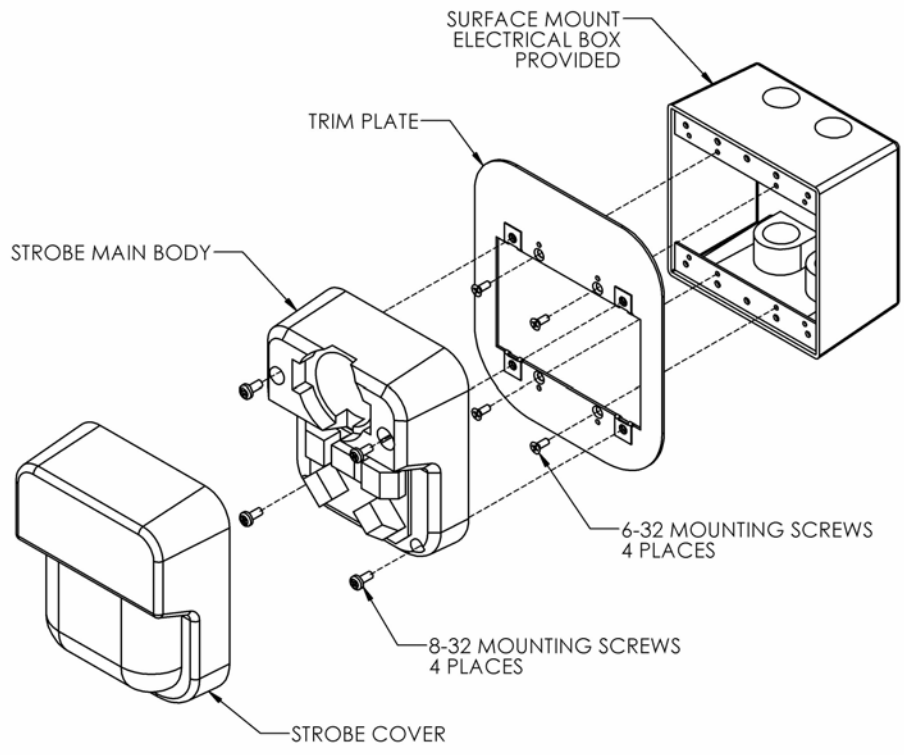

Figure 4

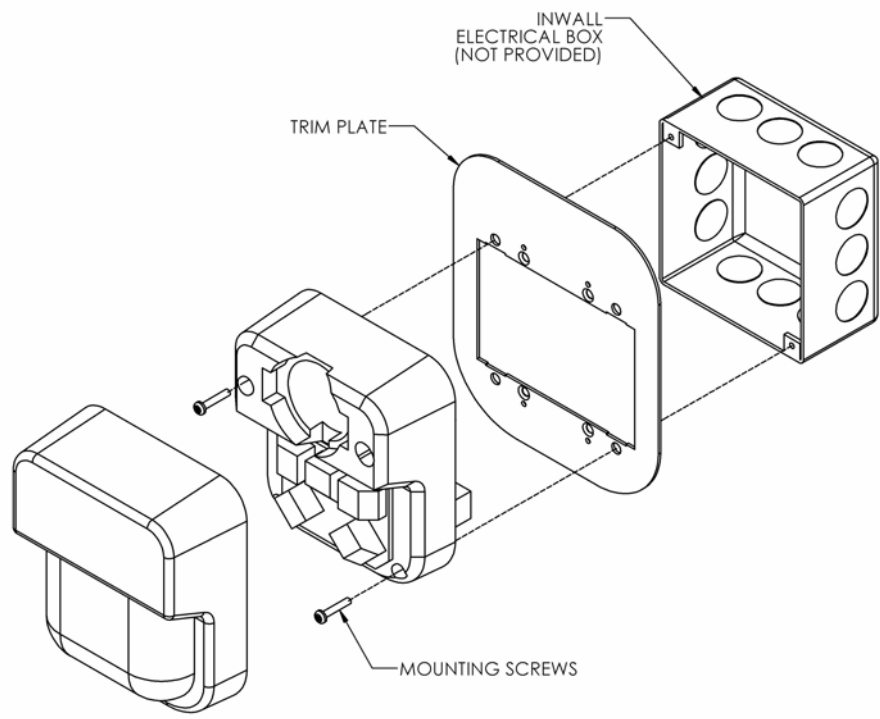

Figure 5