



Quick Install Guide

AA1MLPE VPN



Items Included in Kit

The following items are included in your W480 delivery.

1. Watchman 480 Unit
2. 12 Volt DC Power Supply
3. Magnetic Read Switch
4. Keys
5. Nuts **X 4**
6. Bolts **X 4**
7. Install Guide
8. Customer Information Packet

NOTE Leave one key with the customer.

Wiring Examples

Watchman W480 Unit

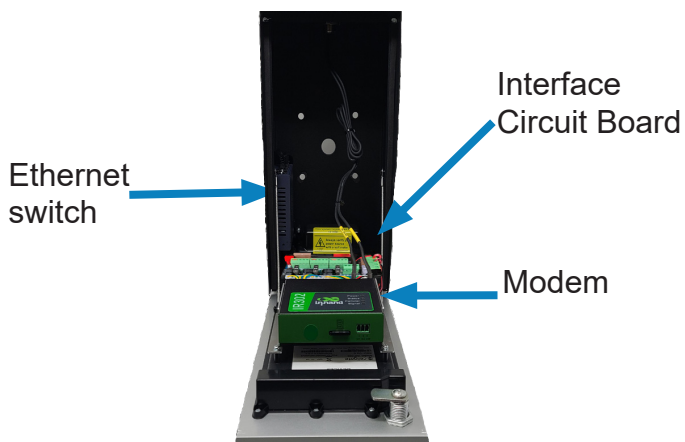

Power Supply Wiring

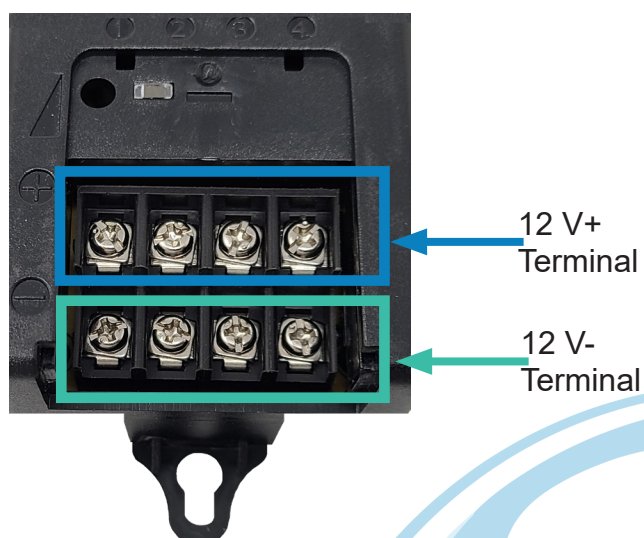

Recommended wiring: 18/6 shielded for main device, and 18/4 shielded for optional Wiegand devices.

Interface Circuit Board

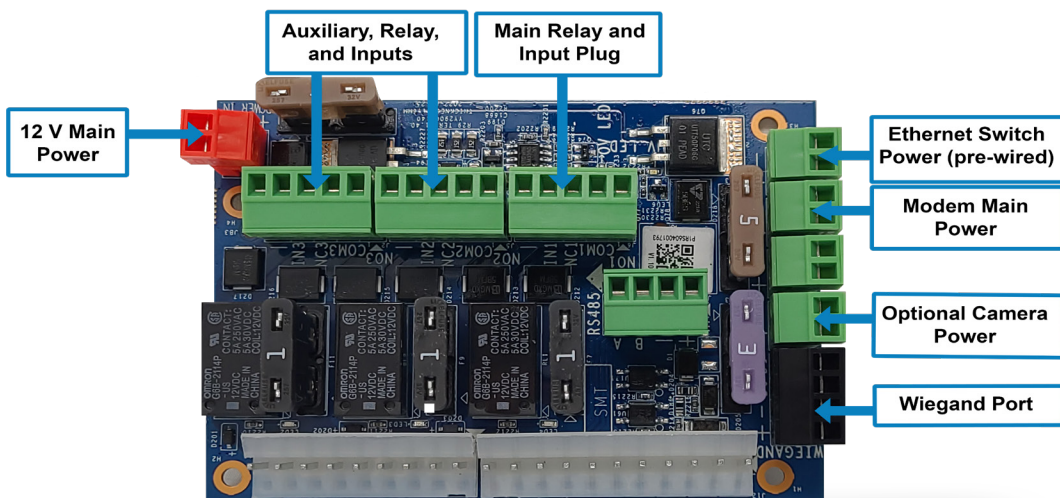

The circuit board is oriented the same as the Watchman install.

If you requested an expansion board, we installed it.

We recommend the following gauges (ga) for each distance:

- 18 ga stranded: up to 25 ft
- 16 ga stranded: up to 50 ft
- 12 ga stranded: up to 60 ft



VPN Connection

Product Numbers: AA1MLPE VPN



The VPN connection ships DHCP enabled and **does not** support external cameras.

In the image to the left, the black chord is the Ethernet connection.



NOTE Ethernet connection is **required**.

NOTE **Do not** remove SIM card from the in-hand modem.



WATCHMAN[®]
Your Virtual Security Guard

by  cellgate

Wiring with Transformer

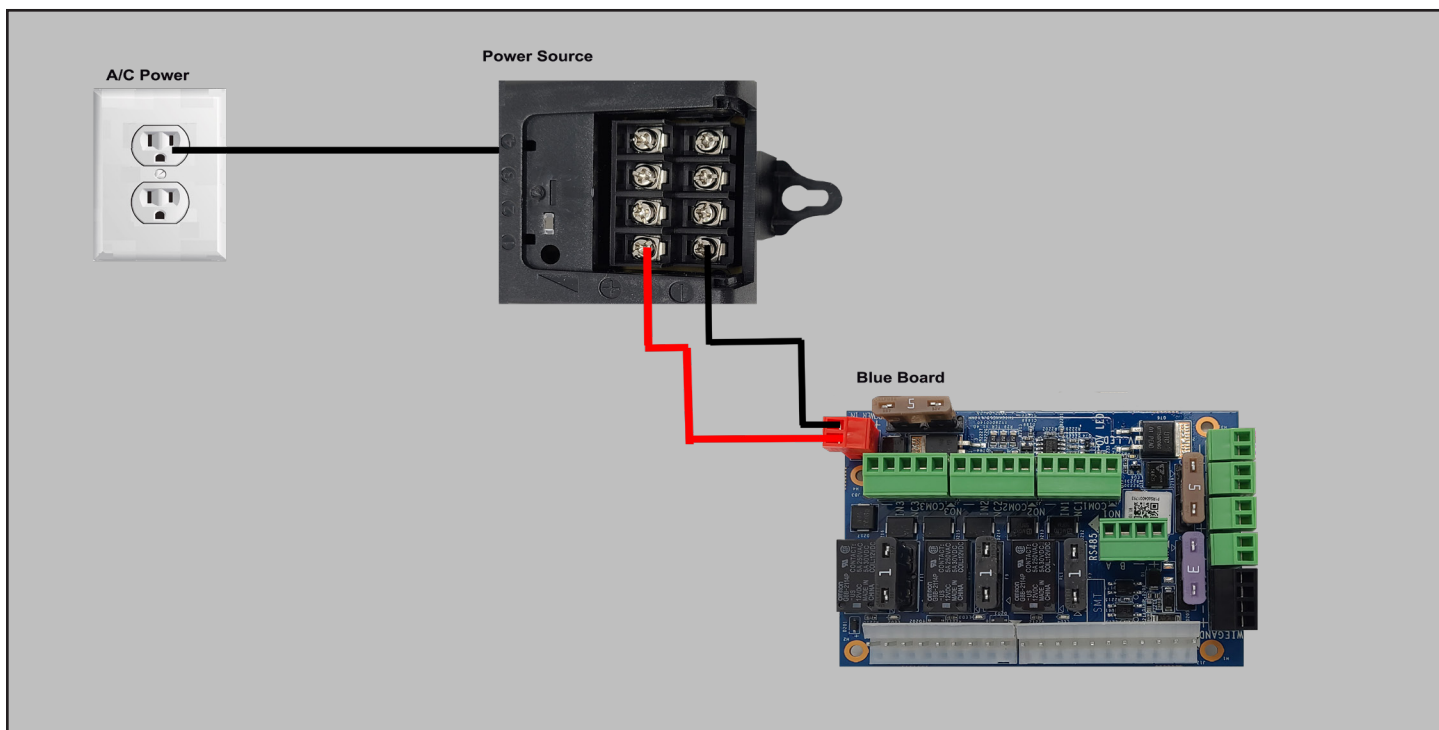

Wiring for Solar Power

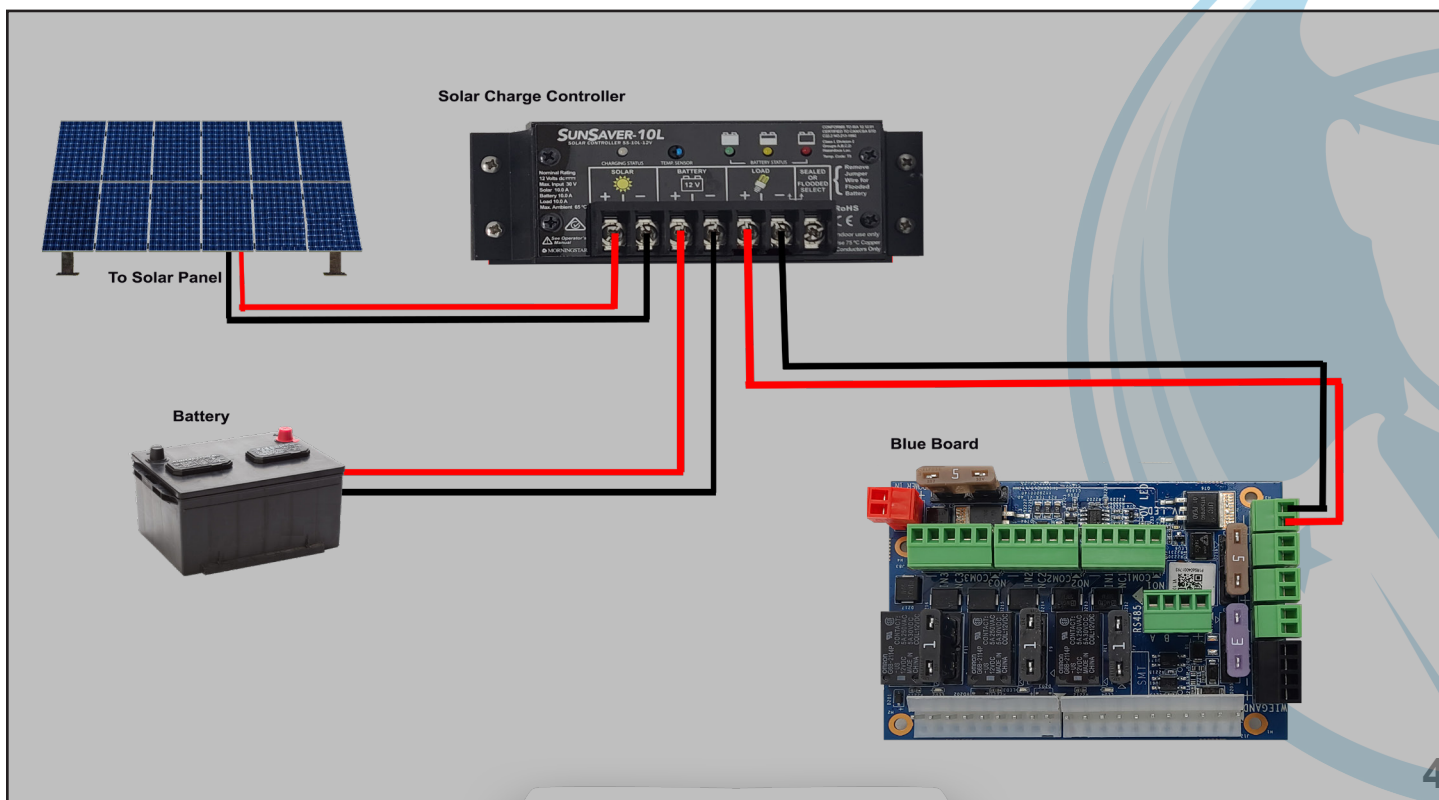



Interface Wiring Diagram Oriented the same as the Watchman install

The supplied diode must be used for all magnetic lock installations, or the warranty is voided.

Main Power
12 V Input
Power
Red: Positive
Black: Negative

To Magnetic Switch or Dry Contact on Operator
Gray: Negative
White: Positive

To Gate Operator
Free Exit or Exit Terminal
Brown: Common Ground
Blue: Normally Open Connection

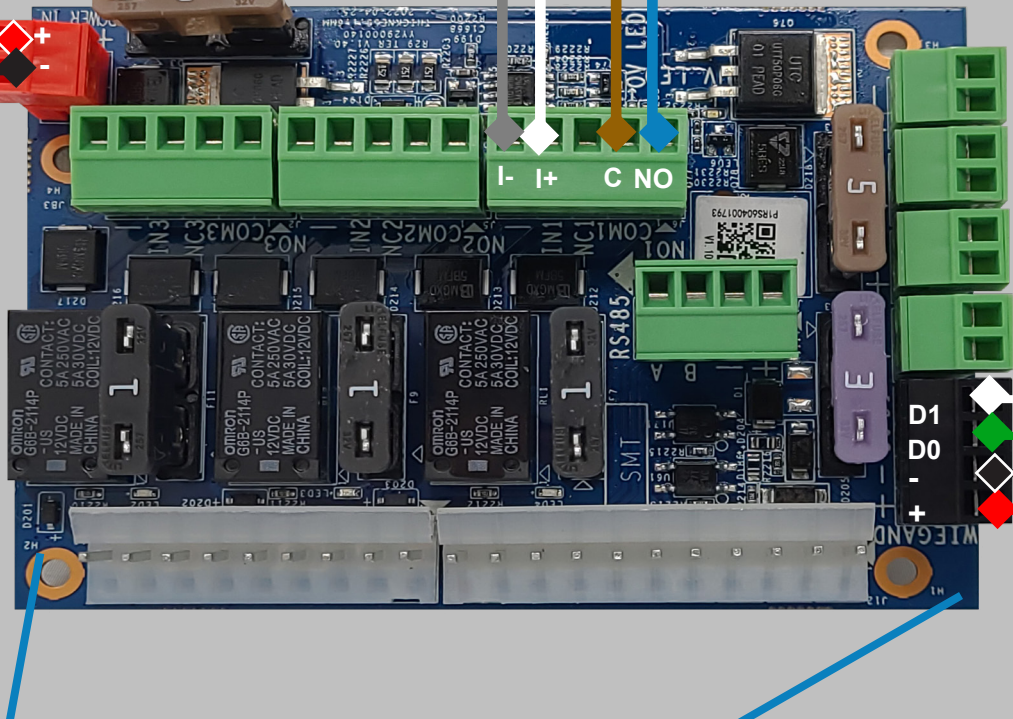

Optional Wiegand 26 Bit Connection
White: Data 1
Green: Data 0
Black: Negative
Red: Positive

6-Wire Installation Instructions

1. Wire main power from the transformer to the power connector on the circuit board.
2. Connect gate trigger wires from the Normally Open (NO) and Common (C) to the free-exit or exit terminals on the gate operator.
3. Connect the gate status wires on the 6 pin connector on the main relay and input plug to the magnetic switch or a Dry Contact, Normally Closed (NC) relay on the gate operator.
4. If using an optional 26-bit reader (e.g., keypad, card reader, RFID, clicker), wire the device to the Wiegand connection on the interface circuit board.
5. Use *Camera Guide* if adding external camera.
6. Test and activate using the test credentials on the *Activation & Test Process* document.





WATCHMAN®
Your Virtual Security Guard

by cellgate

Dry Contact Relay, Normally Open Dry Contact No Voltage to Lock or Gate

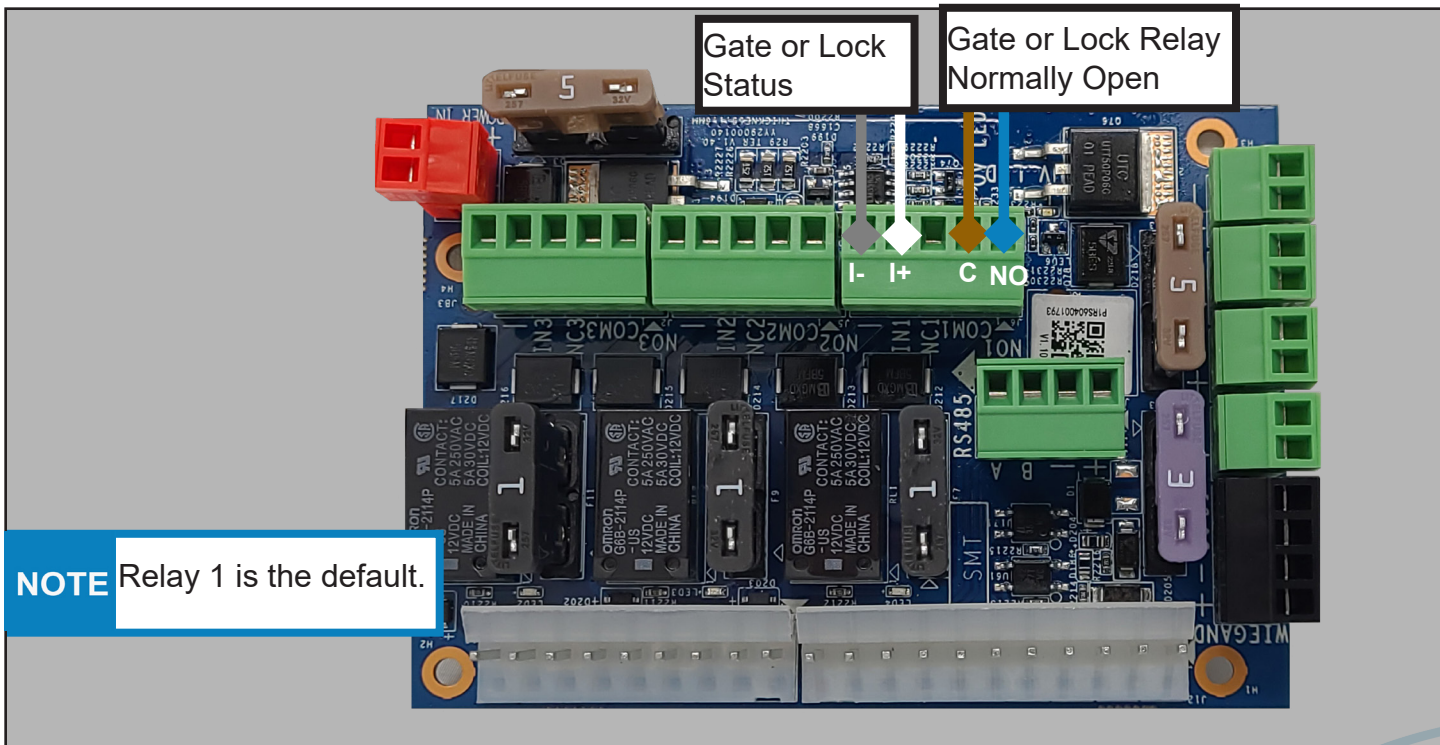

Dry Contact Relay, Normally Closed Dry Contact No Voltage to Lock or Gate

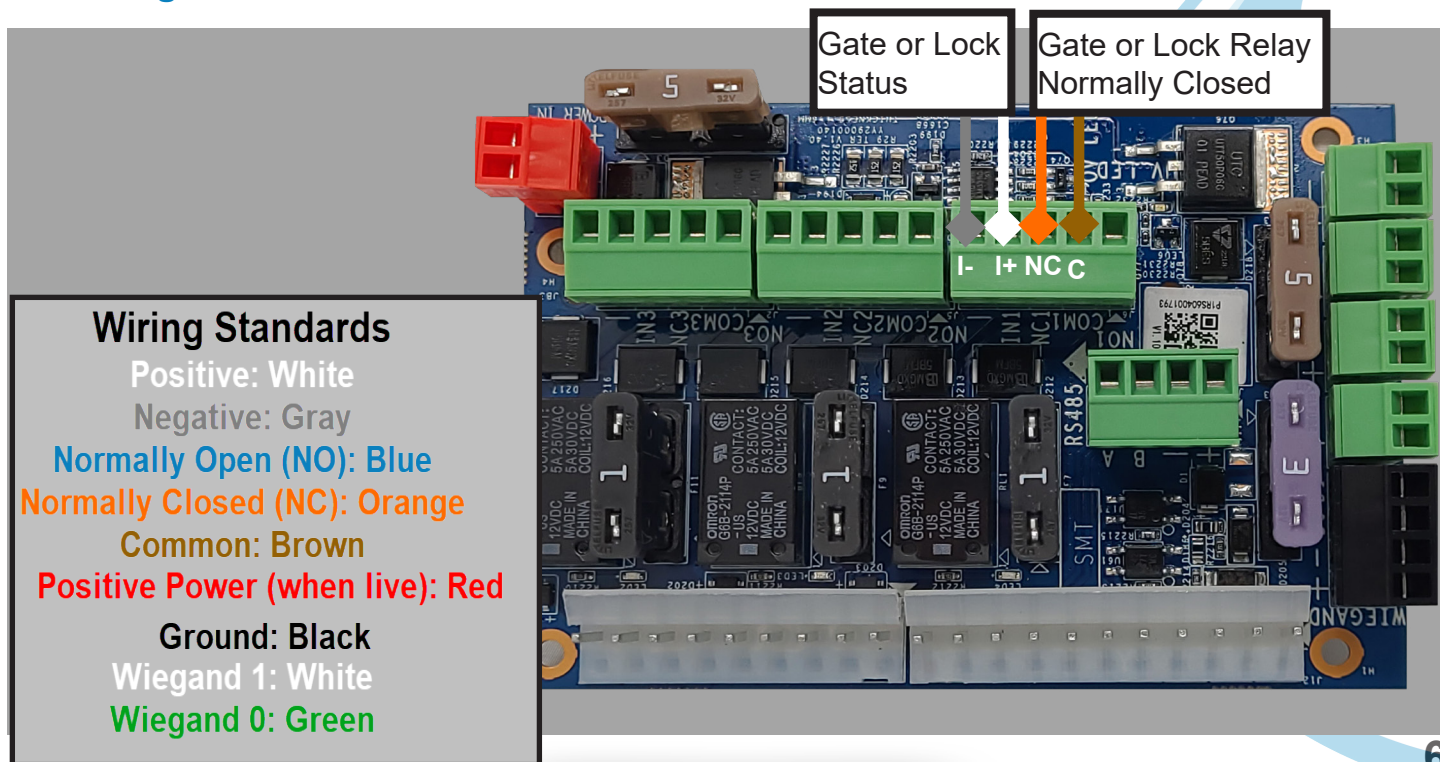



WATCHMAN®
Your Virtual Security Guard

by cellgate

Lock Requiring Constant 12 V: Wet Contact Relay, Normally Open

Door/lock opens (releases) when power is added.

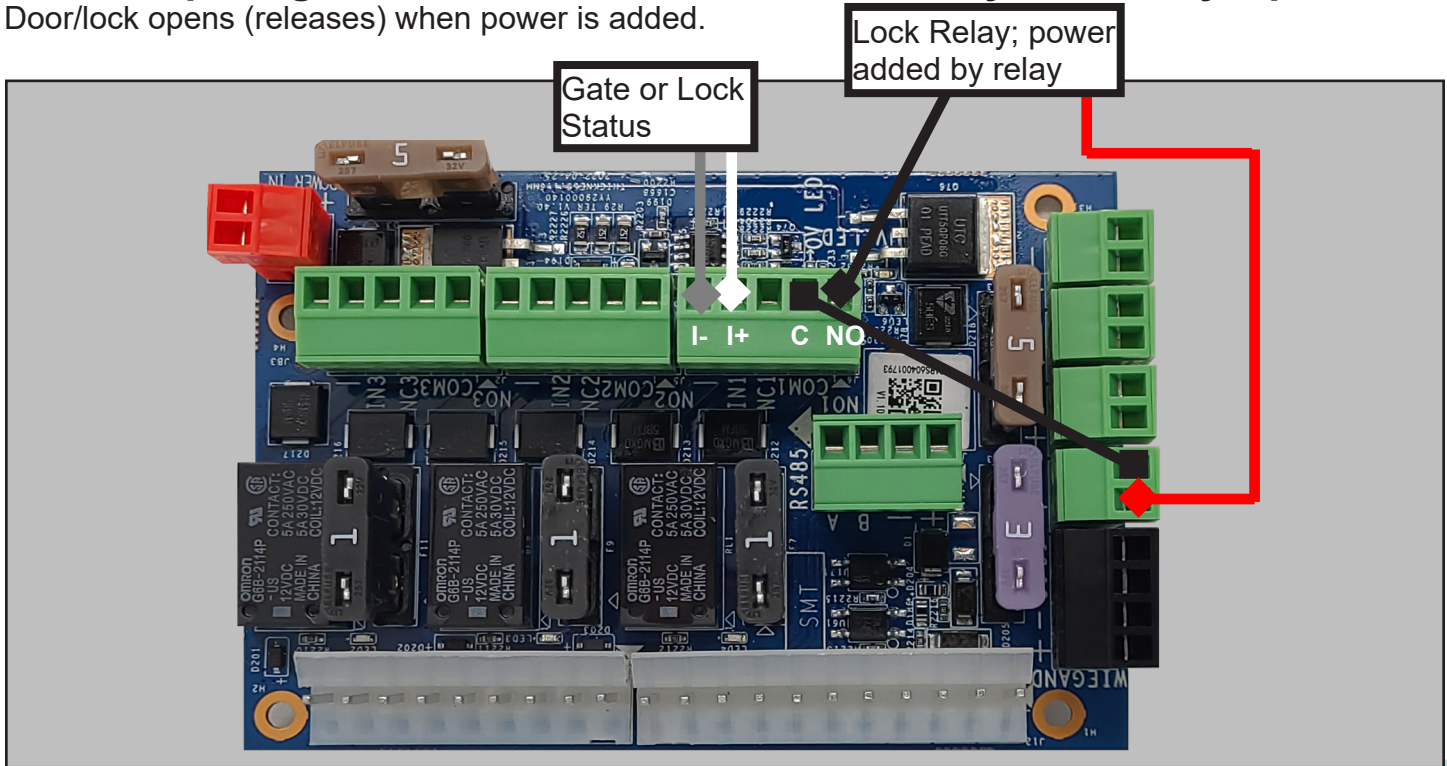

Lock Requiring Constant 12 V: Wet Contact Relay, Normally Closed

Door/lock opens (releases) when power is removed.

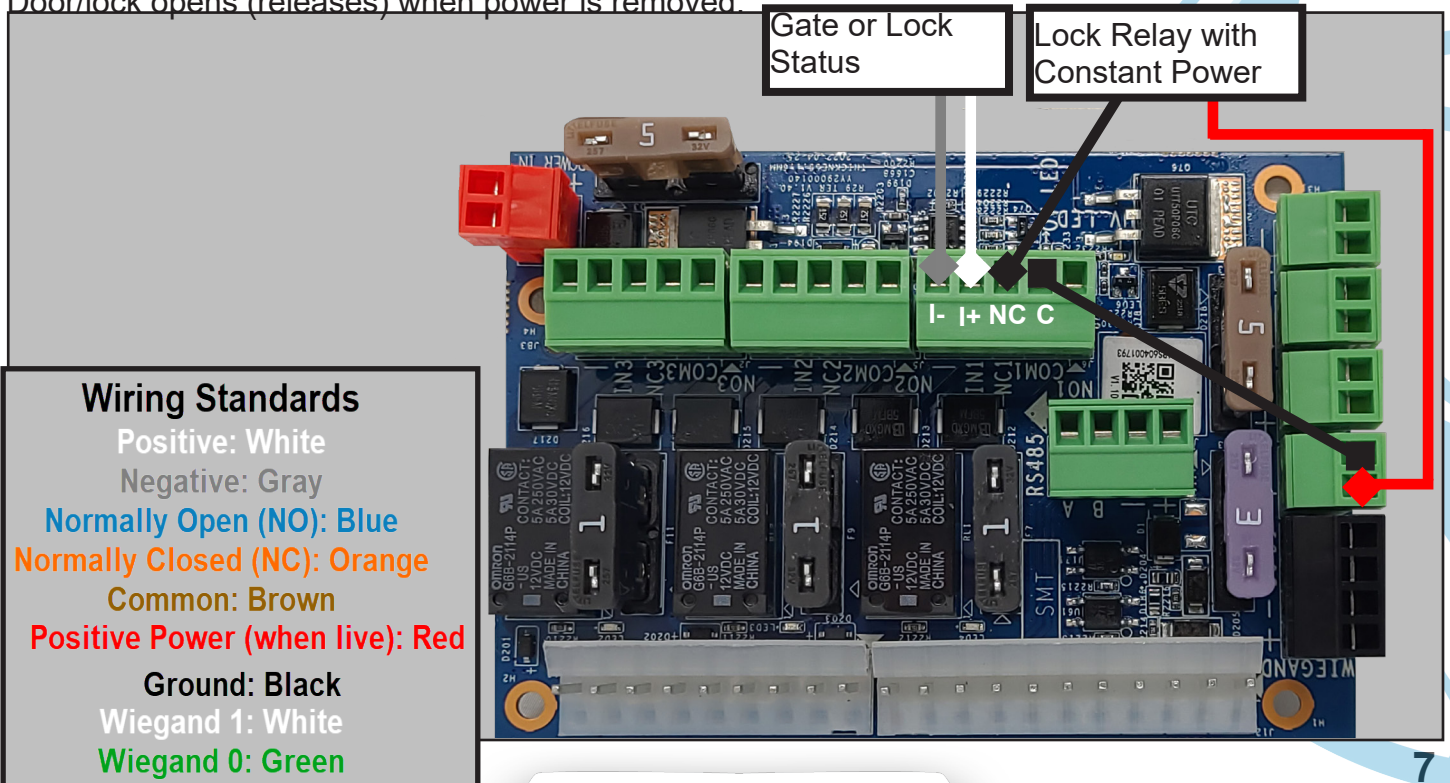

Wiring Standards

Positive: White

Negative: Gray

Normally Open (NO): Blue

Normally Closed (NC): Orange

Common: Brown

Positive Power (when live): Red

Ground: Black

Wiegand 1: White

Wiegand 0: Green



WATCHMAN[®]
Your Virtual Security Guard

by  **cellgate**

Wiegand Wiring to Board and Direct to Faceplate, 26 Bit Reader To Interface Board

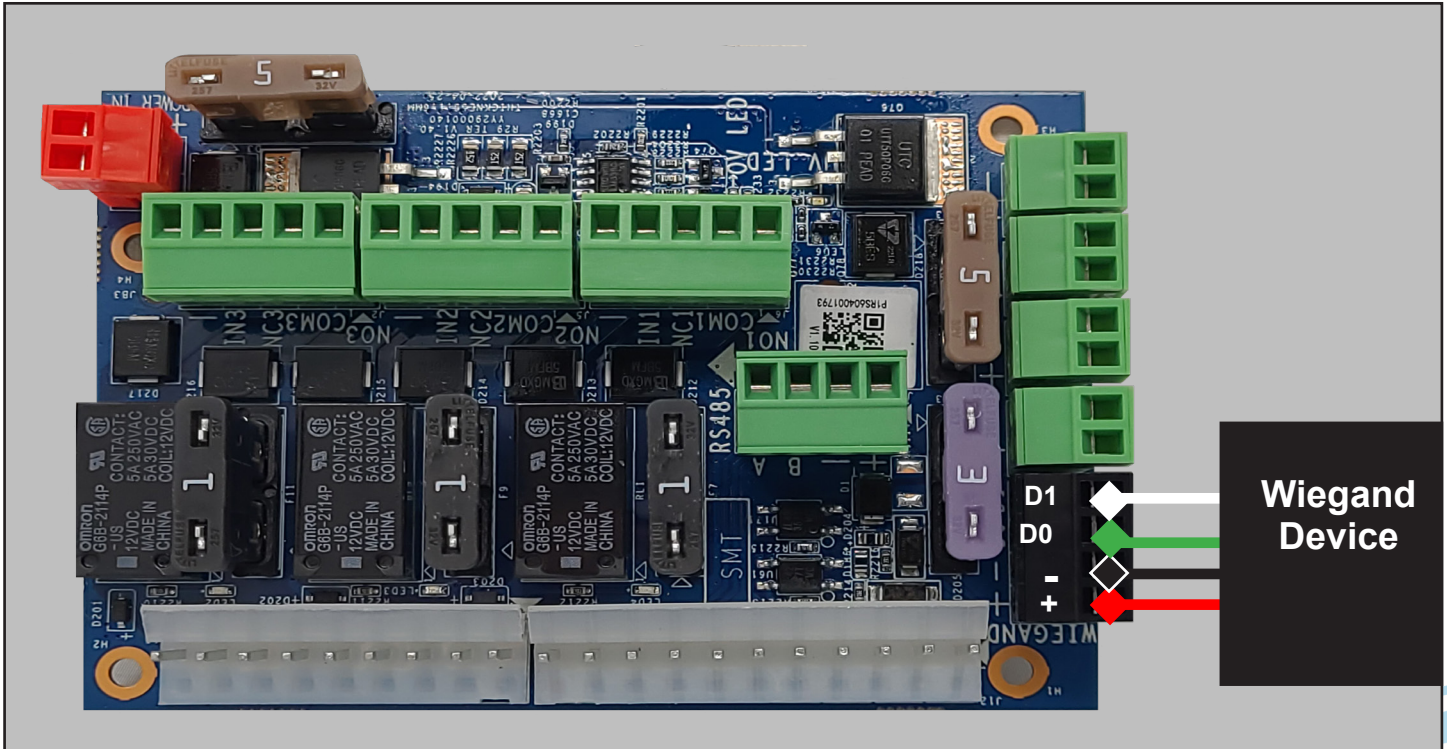

Wiring Standards

Positive: White

Negative: Gray

Normally Open (NO): Blue

Normally Closed (NC): Orange

Common: Brown

Positive Power (when live): Red

Ground: Black

Wiegand 1: White

Wiegand 0: Green



Magnetic Switch Setup

The Mag Switch can be placed anywhere that allows A and B to be pulled at least 2 inches away from each other when the gate is open and within 1.5 inches when the gate is closed.

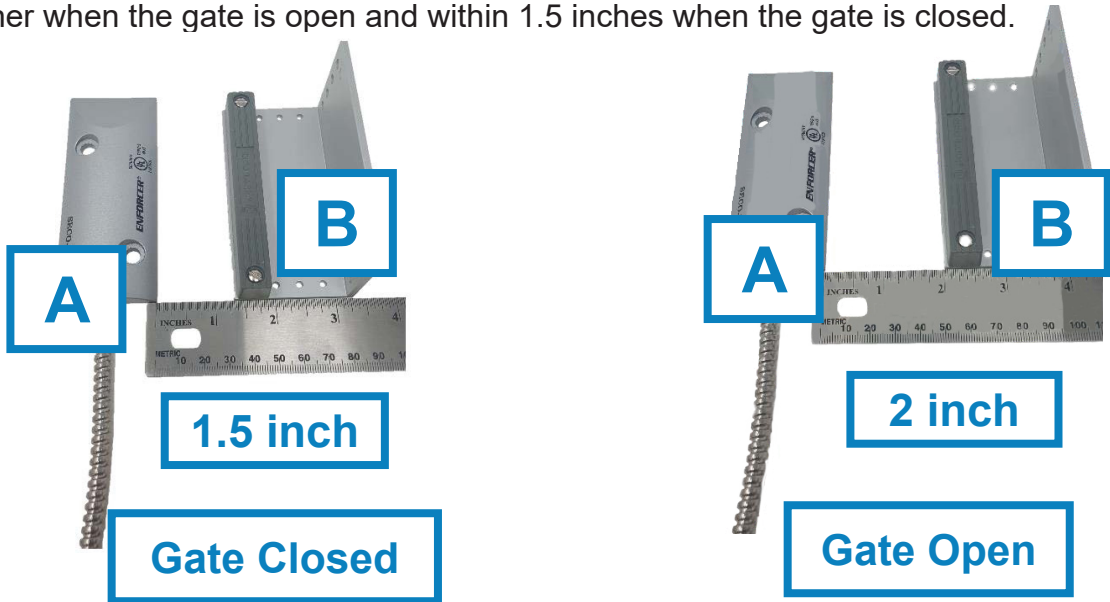

NOTE Gate statuses can be inverted. If needed, call CellGate to invert.

Magnetic Switch Wiring

Gate Wiring

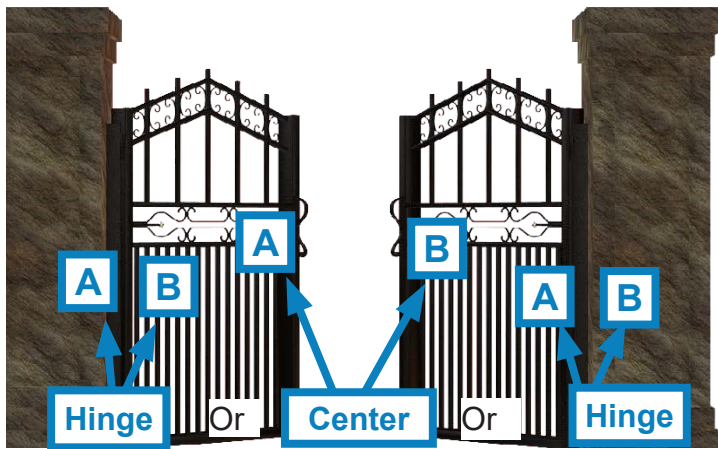

Door Wiring

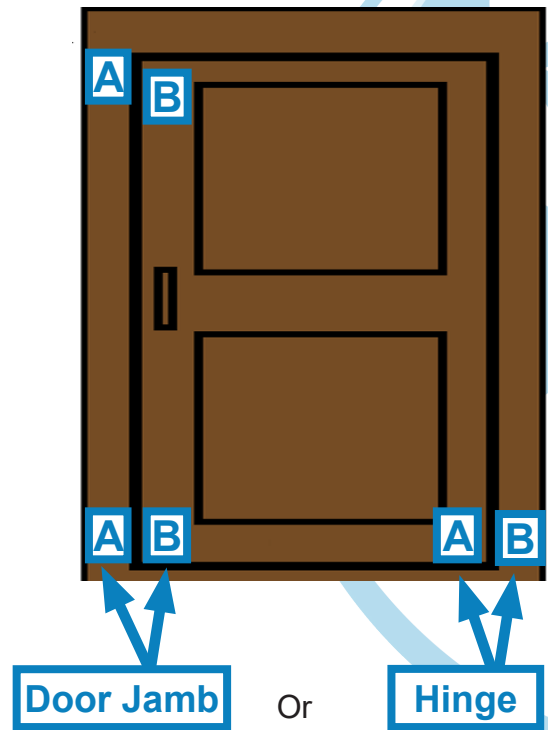



WATCHMAN[®]
Your Virtual Security Guard

by  cellgate

Mounting to Standard Pedestal Mount

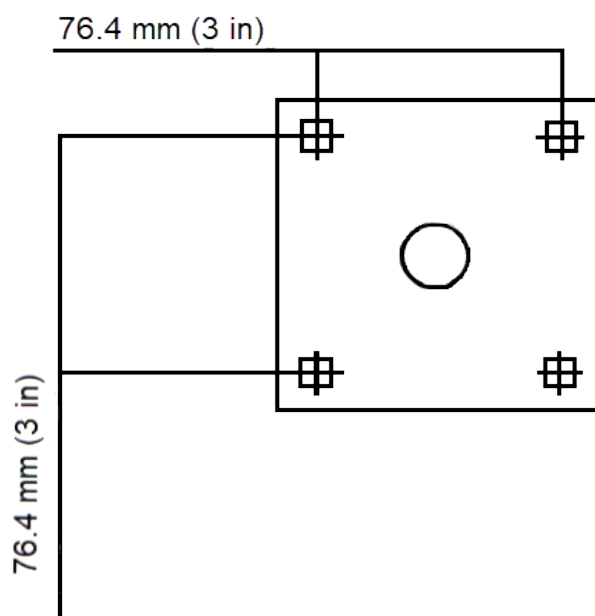
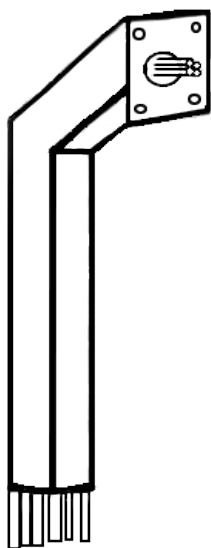
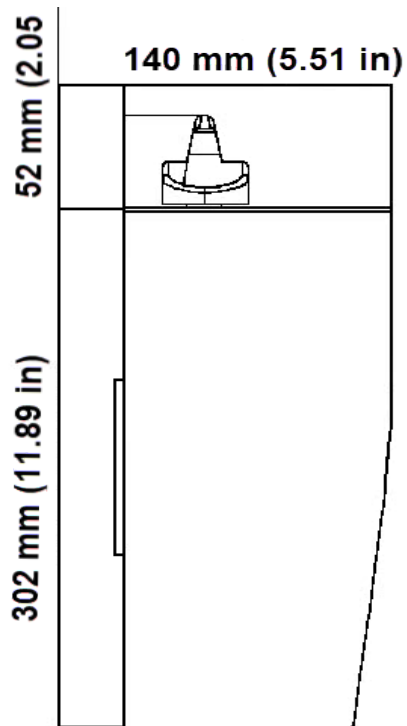
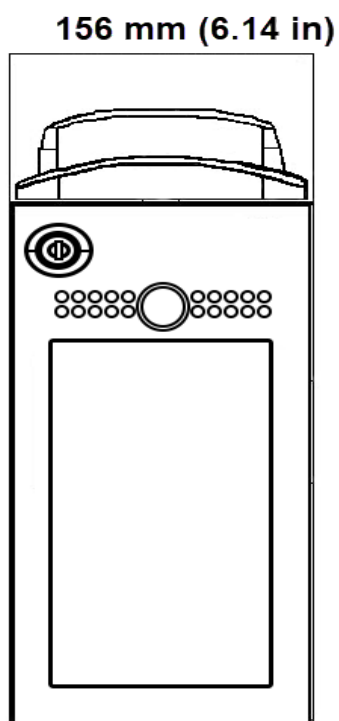



WATCHMAN®
Your Virtual Security Guard

by  cellgate

Mounting to Standard Pedestal Mount, Continued

