



SD1-T | SD1sm-T | SD1g-T PRODUCT SPECIFICATIONS

Frequency Response	60 Hz - 15 kHz (Nominal w/o EQ, substrate dependent)
Max. Program Power	100 W, with 100Hz 12 dB / oct high-pass
Max Continuous Power ¹	30 W
Max. SPL @ 1 m (100 Hz - 10 kHz)	88.8 dB Drywall (equivalent to conventional in-wall @ 4m)
Sensitivity dB @ 2.83 V / 1 m ²	Nominal, 70 - 75 dB
Distance Factor	Approximately ±4 dB Distance Doubling
Effective 1 W / 1 m Sensitivity	74 dB Drywall (Equivalent to conventional in-wall @ 4 m)
Impedance (Nominal)	8 Ω
Coverage Angle @ 50 Hz - 3 kHz	Greater than 120° (See Graph)
Inputs	Wire lead with screw connector block
Diameter: Housing Body	58 mm 2.3"
Diameter: Mounting Foot	89 mm 3.5"
Height	51 mm 2.02"
Weight	0.54 kg 1.2 lbs
Packaging	1 per box

Notes

- ¹ Solid substrates systems are excursion limited at low frequencies. For higher SPL levels, a 12 dB/oct high-pass filter at 100 Hz or above is recommended
- ² Sensitivity is dependent on substrate type, substrate thickness, size (larger-higher), drive location (center of panel usually highest), frequency, etc. Variation in the midband dependent on these factors, can be +/- 5dB or more.
- ³ Since radiation is from a large surface, the decrease in SPL (approximately -4 dB) with distance is significantly less than a conventional in-wall speaker (-6 dB for every doubling of distance). This causes an apparent higher 1m sensitivity at listening distance
- ⁴ Since the substrate is the Speaker, EQ is required for best response. Induction Dynamics has available a compact passive network to EQ the mid/high frequencies. Available are custom networks for drywall, glass and table top.
- ⁵ All Graph Data Smoothed 1/3 Octave

Description & Applications

SolidDrive is a patent-pending technology with lasting visual appeal that delivers maximum audio performance because it literally mounts inside walls, on tables or directly to glass surfaces. Four SolidDrive options ensure maximum performance across multiple substrates including desktops, glass, metal, wood, ceramics, laminates and composites. Sturdy mounting for drywall applications come from a patent-pending, galvanized steel balanced cantilever spring bracket that attaches directly to studs. Glass models come with a proprietary, double-sided VHB adhesive disc and surface mount models can be attached directly to the surface through a custom designed mounting foot. Desktop models ship with a silicone pad specifically engineered to transfer maximum acoustical energy to the substrate. All mounting hardware is included with each SolidDrive.

Features

- SolidDrive is a patent-pending technology that utilizes neodymium magnets and dual symmetrically opposed motors to convert audio signals into acoustical energy in a wide variety of substrates.
- With direct contact to glass, drywall and tabletops, SolidDrive units radiate full-range sound across the entire surface.
- Full-frequency sound can be delivered from 60 Hz – 15 kHz with a max SPL of 88.8 dB and a coverage angle greater than 120° (60 Hz – 3 kHz).
- Capable of handling 5 – 100 Watts, SolidDrive units can deliver single to multi-channel audio for home theater, home audio and commercial audio applications.
- Patent pending balanced cantilever spring bracket for behind-wall mounting allows for a completely hidden speaker system in drywall applications.
- For extended system performance, active and passive subwoofers are available
- SolidDrives operate in a virtually friction-free environment and are engineered for infinite life. Induction Dynamics SolidDrives come with a 7- year warranty

Frequency Response – Typical Dry-wall SolidDrive Response

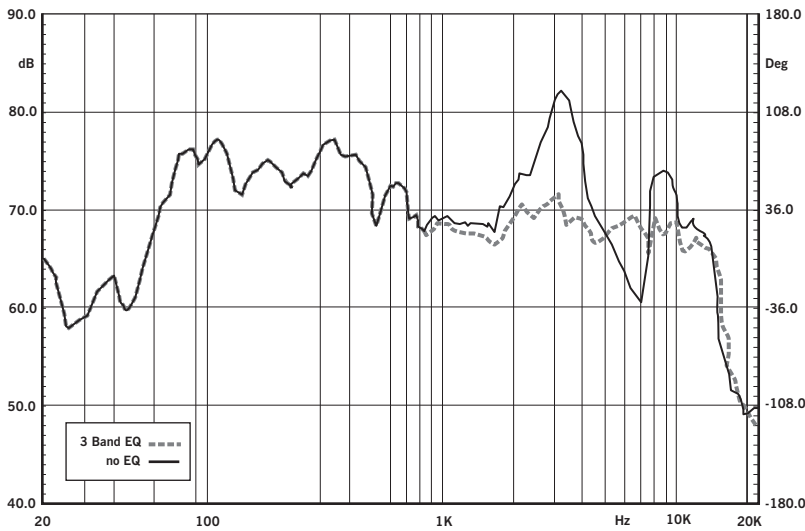

Frequency Response – Typical Wood Table-Top SolidDrive Response

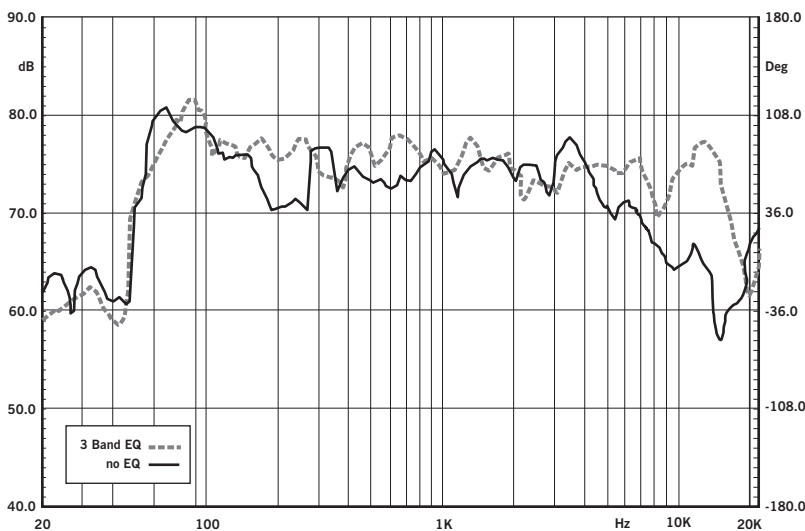

Frequency Response – Typical Glass SolidDrive Response

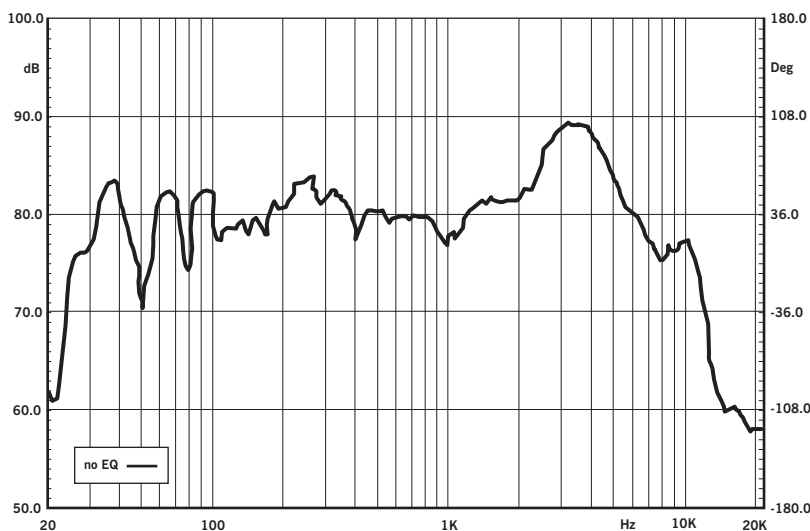

Emulating de-classified military sonar technology, the SolidDrive transforms almost any solid surface into a phase-independent, wide dispersion loud speaker. Pressure waves emit uniformly from the surface regardless of the location of the SolidDrive.

Optional SolidDrive Passive Equalization Modules

The surface material plays a key role in the system's sound performance. To ensure an optimal listening experience, the SolidDrive SD1 system can be equalized with the optional SolidDrive Passive Equalization Module. Each PEM increases the system's sound performance with a passive equalizer network specifically engineered for the particular substrate it is intended for. One one is used with each SolidDrive and are available for drywall, wood, and glass. The SD1 Desktop model ships with the PEM for wood included.

SolidDrive "In-Wall" Subwoofer Options

SolidDrive subwoofers are the ideal companions to the SolidDrive and are available in two basic models. The SW7.iw utilizes a single 7" driver. The SW8.iw utilizes dual 8" drivers. The 8" is an active subwoofer whereas the 7" is available as an active or passive subwoofer. Both models can be ordered individually or with the 200-Watt SolidDrive A4 Subwoofer Amplifier.

SolidDrive subwoofers provide deep, accurate bass and are designed to be easily installed inside the wall between wall studs without altering a room's design.

Patented Technologies

MSE Audio Group is constantly developing new technologies that enhance audio product performance. MSE Audio Group innovations are protected by multiple U.S. and international patents. MSE Audio Group actively defends its patents in order to protect resellers and end users.

Technical Data and Specification Tools

Technical Data

Induction Dynamics and SolidDrive strive to provide complete and effective technical information and data to dealers, engineers and designers. All data are available from Induction Dynamics.

Data Acquisition

All performance data acquired within MSE Audio Group are analyzed using a variety of standard measurement techniques, including Measured Length Sequence (MLS) and Time Delay Spectrometry (TDS). Performance, development and data acquisition tools include:

Gold Line TEF 20, CLIO, LMS, LEAP, and proprietary modeling software. EASE™ data are acquired through an automated CLIO/Outline/EASE™ interface.

Architectural Specifications

The loudspeaker shall consist of a full-frequency range transducer constructed of neodymium magnets.

Performance specifications are dependent upon substrate type and size. Typical production unit specifications shall be as follows: Useable frequency response shall extend from 60 Hz – 15 kHz (-10 dB, half space, no external equalization). Measured sensitivity (2.83 Volt input, 1 meter) shall be at least 70 – 75 dB. The

speaker shall have a nominal impedance of 8 Ohms. Rated power capacity shall be at least 30 Watts continuous power (RMS) and conform to EIA-426-B testing. Maximum continuous input at 1 meter shall be 88.8 dB (drywall).

Installation for the SolidDrive shall be; galvanized steel mounting bracket for drywall; double-sided adhesive disc for glass; direct screw mounting for surface mount (wood, etc.).

The enclosure shall be constructed of chrome plated aluminum.

Overall cabinet dimensions for the SD1 and SD1sm shall be no more than 52.8mm (2.08 in) in height by 88.9 mm (3.50 in) in diameter. The SD1 shall weigh no more than 0.54 kg or 1.2 Lbs.

Overall cabinet dimensions for the SD1 Desktop and SD1g shall be no more than 52.8 mm (2.08 in) in height by 57.9 mm (2.28 in) in diameter. The SD1 shall weigh no more than .050 G or 1.1 Lbs.

SolidDrive models shall come with the following leads:
 SD1 – 559 mm (22 in.) plenum rated speaker wire with screw connector block.
 SD1g – 1829mm (72 in) clear speaker wire with screw connector block.
 SD1sm – 1829mm (72 in) clear speaker wire with screw connector block.
 SD1 desktop – 1829mm (72 in) black speaker wire with gold RCA plug.

Impedance Response, All Surfaces – Nominal 8 ohm

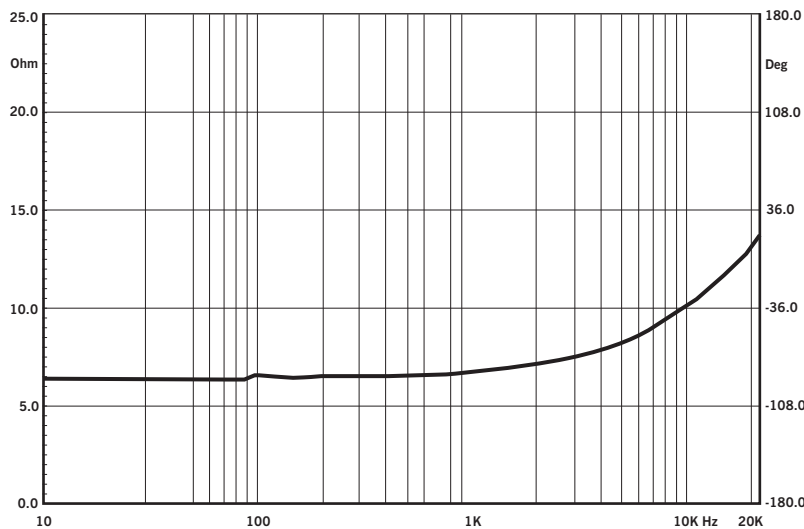

Directivity Index (DI) - Off Axis Response On 4x8' Drywall Panel
Outdoors in 4' Direction Referenced to 0deg @2m

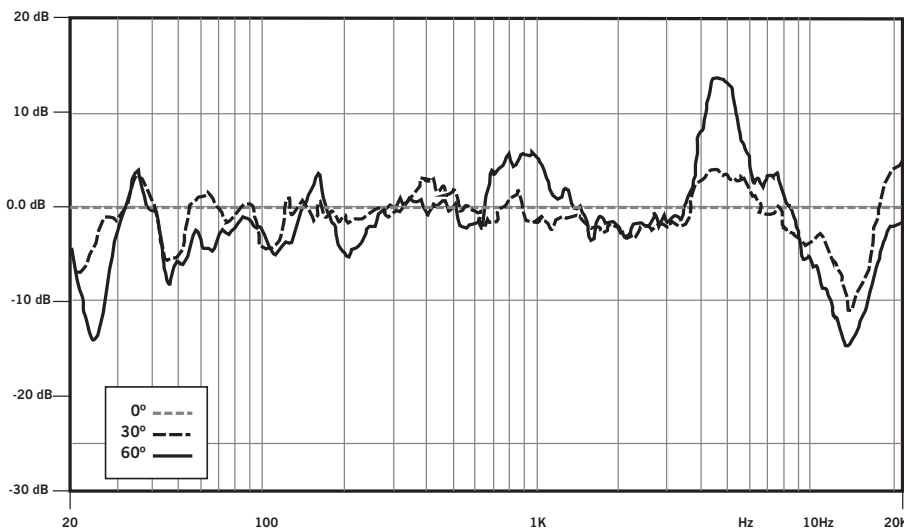

Mechanical Drawings

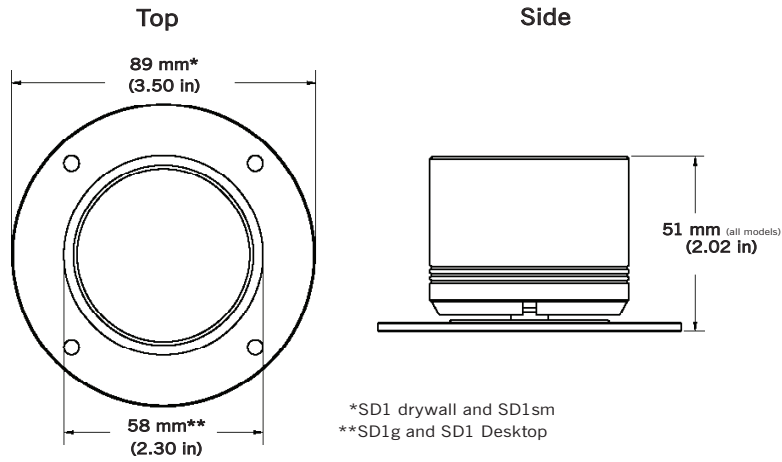

Mounting Options

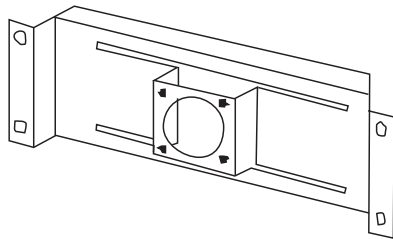

In-wall mount
included with SD1

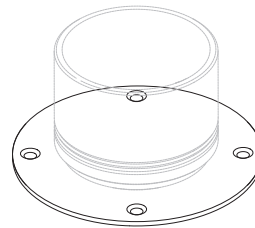

Surface mount - mounts screws from back
included with SD1sm

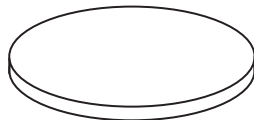

Double sided VHB pad
included with SD1g

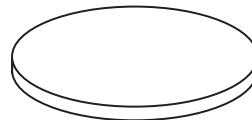

Silicone pad
included with SD1 Desktop