

ANALOG CAMERA

User Manual

HCF-8011RV

Analog Camera

User Manual

Copyright

©2023 Hanwha Vision Co., Ltd. All rights reserved.

Trademark

Each of trademarks herein is registered. The name of this product and other trademarks mentioned in this manual are the registered trademark of their respective company.

Restriction

Copyright of this document is reserved. Under no circumstances, this document shall be reproduced, distributed or changed, partially or wholly, without formal authorization.

Disclaimer

Hanwha Vision makes the best to verify the integrity and correctness of the contents in this document, but no formal guarantee shall be provided. Use of this document and the subsequent results shall be entirely on the user's own responsibility. Hanwha Vision reserves the right to change the contents of this document without prior notice.

❖ Design and specifications are subject to change without prior notice.

Safety information



CAUTION

RISK OF ELECTRIC SHOCK.
DO NOT OPEN



CAUTION:

TO REDUCE THE RISK OF ELECTRIC SHOCK, DO NOT REMOVE COVER (OR BACK) NO USER SERVICEABLE PARTS INSIDE. REFER SERVICING TO QUALIFIED SERVICE PERSONNEL.



This symbol indicates that dangerous voltage consisting a risk of electric shock is present within this unit.



This exclamation point symbol is intended to alert the user to the presence of important operating and maintenance (servicing) instructions in the literature accompanying the appliance.

WARNING

- To prevent damage which may result in fire or electric shock hazard, do not expose this appliance to rain or moisture.
- To prevent injury, this apparatus must be securely attached to the floor/wall in accordance with the installation instructions.

WARNING

1. Be sure to use only the standard adapter that is specified in the specification sheet. Using any other adapter could cause fire, electrical shock, or damage to the product.
2. Incorrectly connecting the power supply or replacing battery may cause explosion, fire, electric shock, or damage to the product.
3. Do not connect multiple cameras to a single adapter. Exceeding the capacity may cause abnormal heat generation or fire.
4. Securely plug the power cord into the power receptacle. insecure connection may cause fire.
5. When installing the camera, fasten it securely and firmly. The fall of camera may cause personal injury.
6. Do not place conductive objects (e.g. screwdrivers, coins, metal parts, etc.) or containers filled with water on top of the camera. doing so may cause personal injury due to fire, electric shock, or falling objects.
7. Do not install the unit in humid, dusty, or sooty locations. doing so may cause fire or electric shock.

Safety information

8. If any unusual smells or smoke come from the unit, stop using the product. In such case, immediately disconnect the power source and contact the service center. Continued use in such a condition may cause fire or electric shock.
9. If this product fails to operate normally, contact the nearest service center. Never disassemble or modify this product in any way. (Hanwha Vision is not liable for problems caused by unauthorized modifications or attempted repair.)
10. When cleaning, do not spray water directly onto parts of the product. Doing so may cause fire or electric shock.

CAUTION

1. Do not drop objects on the product or apply strong shock to it. Keep away from a location subject to excessive vibration or magnetic interference.
2. Do not install in a location subject to high temperature, low temperature, or high humidity. Doing so may cause fire or electric shock.
3. If you want to relocate the already installed product, be sure to turn off the power and then move or reinstall it.
4. Remove the power plug from the outlet when there is a lightning. Neglecting to do so may cause fire or damage to the product.
5. Keep out of direct sunlight and heat radiation sources. It may cause fire.
6. Install it in a place with good ventilation.
7. Avoid aiming the camera directly towards extremely bright objects such as sun, as this may damage the CMOS image sensor.
8. Apparatus shall not be exposed to dripping or splashing and no objects filled with liquids, such as vases, shall be placed on the apparatus.
9. The Mains plug is used as a disconnect device and shall stay readily operable at any time.
10. Do not expose the camera to radioactivity. Radioactivity exposure may damage the CMOS.

FCC Statement

This device complies with part 15 of the FCC Rules. Operation is subject to the following two conditions:

- 1) This device may not cause harmful interference, and
- 2) This device must accept any interference received including interference that may cause undesired operation.

CAUTION

This equipment has been tested and found to comply with the limits for a Class A digital device, pursuant to part 15 of FCC Rules. These limits are designed to provide reasonable protection against harmful interference when the equipment is operated in a commercial environment. This equipment generates, uses, and can radiate radio frequency energy and, if not installed and used in accordance with the instruction manual, may cause harmful interference to radio communications. Operation of this equipment in a residential area is likely to cause harmful interference in which case the user will be required to correct the interference at his own expense.

**IC Compliance Notice**

This Class A digital apparatus meets all requirements of the Canadian Interference.-Causing Equipment Regulations of ICES-003.



Any changes or modifications in construction of this device which are not expressly approved by the party responsible for compliance could void the user's authority to operate the equipment. This device complies with part 15 of the FCC Rules. Operation is subject to the following two conditions: (1) This device may not cause harmful interference, and (2) this device must accept any interference received, including interference that may cause undesired operation.

This equipment has been tested and found to comply with the limits for a Class A digital device, pursuant to part 15 of the FCC Rules. These limits are designed to provide reasonable protection against harmful interference when the equipment is operated in a commercial environment. This equipment generates, uses, and can radiate radio frequency energy and, if not installed and used in accordance with the instruction manual, may cause harmful interference to radio communications. Operation of this equipment in a residential area is likely to cause harmful interference in which case the user will be required to correct the interference at his own expense.

Correct Disposal of This Product (Waste Electrical & Electronic Equipment)

(Applicable in the European Union and other European countries with separate collection systems)

This marking on the product, accessories or literature indicates that the product and its electronic accessories (e.g. charger, headset, USB cable) should not be disposed of with other household waste at the end of their working life. To prevent possible harm to the environment or human health from uncontrolled waste disposal, please separate these items from other types of waste and recycle them responsibly to promote the sustainable reuse of material resources.

Household users should contact either the retailer where they purchased this product, or their local government office, for details of where and how they can take these items for environmentally safe recycling.

Business users should contact their supplier and check the terms and conditions of the purchase contract. This product and its electronic accessories should not be mixed with other commercial wastes for disposal.

Correct disposal of batteries in this product

(Applicable in the European Union and other European countries with separate battery return systems.)

This marking on the battery, manual or packaging indicates that the batteries in this product should not be disposed of with other household waste at the end of their working life. Where marked, the chemical symbols Hg, Cd or Pb indicate that the battery contains mercury, cadmium or lead above the reference levels in EC Directive 2006/66. If batteries are not properly disposed of, these substances can cause harm to human health or the environment.

To protect natural resources and to promote material reuse, please separate batteries from other types of waste and recycle them through your local, free battery return system.

Important safety instructions

1. Read these instructions.
2. Keep these instructions.
3. Heed all warnings.
4. Follow all instructions.
5. Do not use this apparatus near water.
6. Clean only with dry cloth.
7. Do not block any ventilation openings. Install in accordance with the manufacturer's instructions.
8. Do not install near any heat sources such as radiators, heat registers, or other apparatus (including amplifiers) that produce heat.
9. Do not defeat the safety purpose of the polarized or grounding-type plug. A polarized plug has two blades with one wider than the other. A grounding type plug has two blades and a third grounding prong. The wide blade or the third prong is provided for your safety. If the provided plug does not fit into your outlet, consult an electrician for replacement of the obsolete outlet.
10. Protect the power cord from being walked on or pinched particularly at plugs, convenience receptacles, and the point where they exit from the apparatus.
11. Only use attachments/accessories specified by the manufacturer.
12. Use only with cart, stand, tripod, bracket, or table specified by the manufacturer, or sold with the apparatus.
13. Unplug this apparatus when a card is used. Use caution when moving the cart/ apparatus combination to avoid injury from tip-over.
14. Refer all servicing to qualified service personnel. Servicing is required when the apparatus has been damaged in any way, such as powersupply cord or plug is damaged, liquid has been spilled or objects have fallen into the apparatus, the apparatus has been exposed to rain or moisture, does not operate normally, or has been dropped.
15. This product is intended to be supplied by a UL Listed Power Supply Unit marked "Class 2" or "LPS" or "PS2" and rated from 24V AC (50/60 Hz) min. 0.42 A or 12V DC, min. 0.54 A.
16. If you use excessive force when installing the product, the camera may be damaged and malfunction.
If you forcibly install the product using non-compliant tools, the product may be damaged.



Important safety instructions

17. Do not install the product in a place where chemical substances or oil mist exists or may be generated. As edible oils such as soybean oil may damage or warp the product, do not install the product in the kitchen or near the kitchen table.
This may cause damage to the product.
18. When installing the product, be careful not to allow the surface of the product to be stained with chemical substance.
Some chemical solvents such as cleaner or adhesives may cause serious damage to the product's surface.
19. If you install/disassemble the product in a manner that has not been recommended, the production functions/performance may not be guaranteed.
Install the product by referring to "Installation & connection" in the user manual.
20. Installing or using the product in water can cause serious damage to the product.
21. The operating temperature of the product is -30°C to +55°C (-22°F ~ +131°F).



Apparatus shall not be exposed to dripping or splashing and no objects filled with liquids, such as vases, shall be placed on the apparatus

WARNING

To Prevent damage which may caused by IR LED, don't stare at operating lamp.
For below models only.
HCF-8011RV

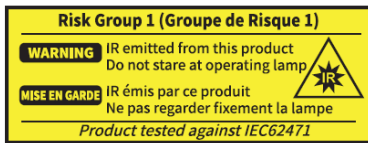

Hanwha Vision cares for the environment at all product manufacturing stages, and is taking measures to provide customers with more environmentally friendly products.

The Eco mark represents Hanwha Vision's devotion to creating environmentally friendly products, and indicates that the product satisfies the EU RoHS Directive.

Overview

WHAT'S INCLUDED

Please check if your camera and accessories are all included in the product package.
(As for each sales country, accessories are not the same.)

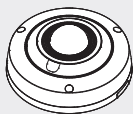

Camera

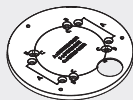

Mounting Plate

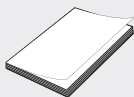

Quick Manual



Installation Guide Sticker



Machine Screws





Torx L wrench

Overview

OPTIONAL ACCESSORIES FOR INSTALLATION

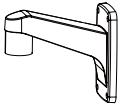
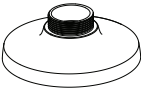
You can purchase appropriate optional accessories available.

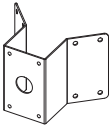
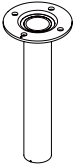
Wall Mount	Hanging Mount	Pole Mount
 SBP-300WM1	 SBP-300HM5	 SBP-300PM
Corner Mount	Ceiling Mount	
 SBP-300KM	 SBP-300CMW	

AT A GLANCE

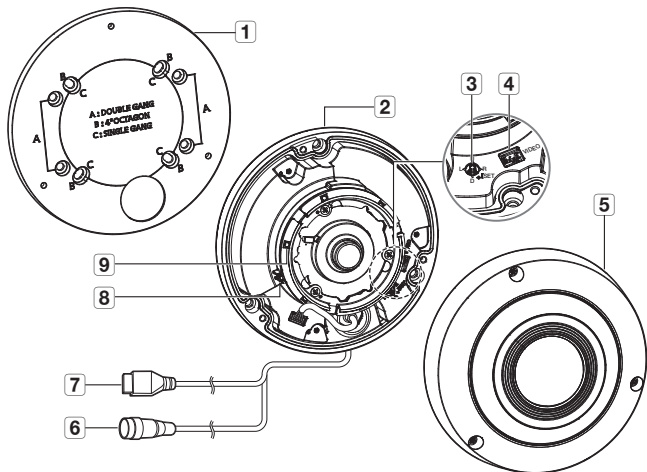

Item	Description
1	Mount plate Plate that fixes the camera when mounting it to the ceiling or attaching it to a separately sold mount.
2	Camera body Body part where the camera lens and connection terminals are included.
3	Function Setup switch Display the menu on the screen and move the cursor to four directions to confirm status or after changing a selected item.
4	Test monitor out port Output port for test monitoring the video output. Use the test monitor cable to connect to a mobile display and check the test video.
5	Dome cover Case cover used to protect the lens and the main unit.
6	Video Output Jack Video signals are output through this port. Connect this port to the Video IN port of a ENCODER.
7	Power Input Connector Used to connect the power.
8	Illumination sensor Detects incoming light to control the IR LED.
9	IR LED These infrared LED's are controlled by the illumination sensor.

Installation

BEFORE INSTALLATION

Ensure you read out the following instructions before installing the camera:

- It must be installed on the area (ceiling or wall) that can withstand 5 times the weight of the camera including the installation bracket.
- Stuck-in or peeled-off cables can cause damage to the product or a fire.
- For safety purposes, keep anyone else away from the installation site. And put aside personal belongings from the site, just in case.
- If the product is installed with excessive force, it may cause damage to the camera due to malfunction. Forcing assembly using non-compliant tools may damage the product.

INSTALLATION

1. Remove the dome cover by loosening the fastening screws by turning them counterclockwise using the supplied Torx L wrench.
 - Note that it is not necessary to loosen the screws completely.

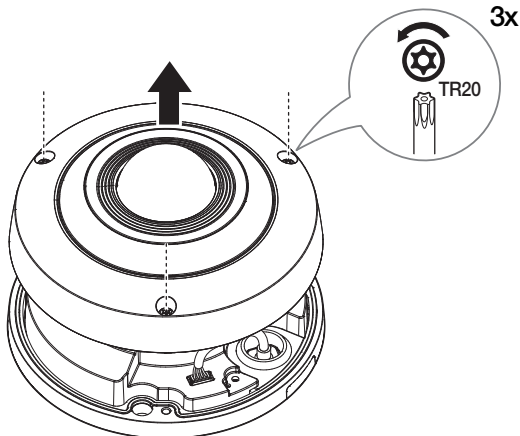

Installation using the installation guide sticker

- 2-1. Attach the installation guide sticker on the desired location and then drill the holes for screws and cables.

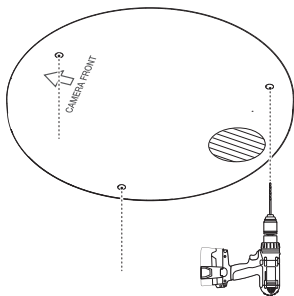

- 2-2. Pull out the power and video cables through the cable hole and connect them with the cables on the camera.

- When installing the camera, arrange the cables so that they are not damaged or caught.

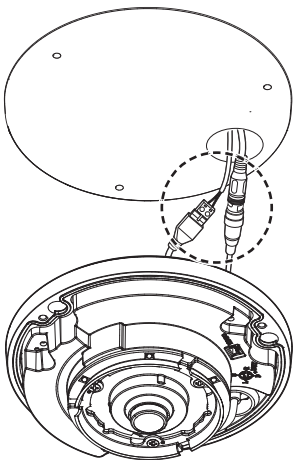

Installation

2-3. Fix the camera body using appropriate screws.

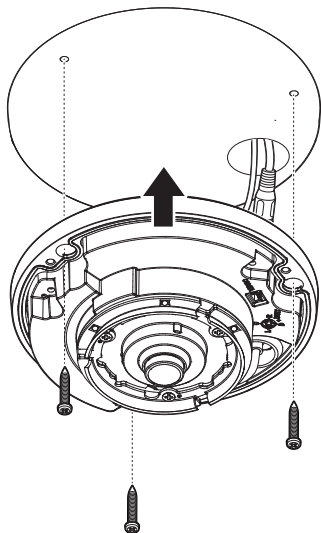

- When connecting cables from the side, first remove the wiring hole cover of the camera body.

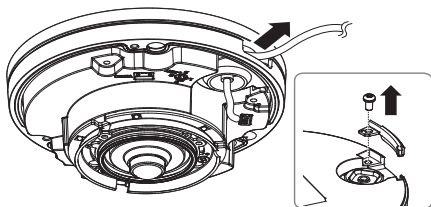

Installation with the mount plate (gang box)

3-1. Fix the camera body using appropriate screws.

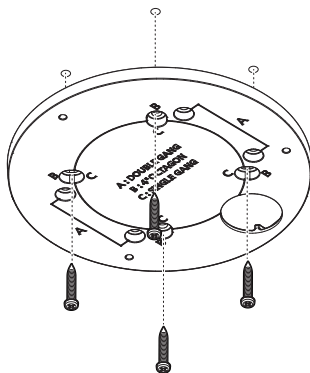

3-2. Pull out the power and video cables through the cable hole and connect them with the cables on the camera.

- When installing the camera, arrange the cables so that they are not damaged or caught.

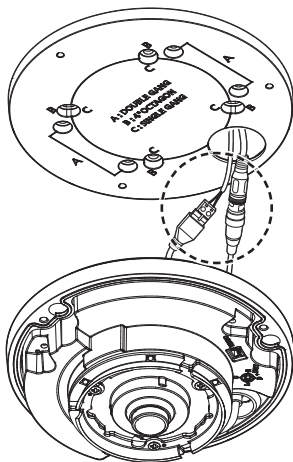

Installation

3-3. Attach the camera body to the mount plate with the supplied machine screws.

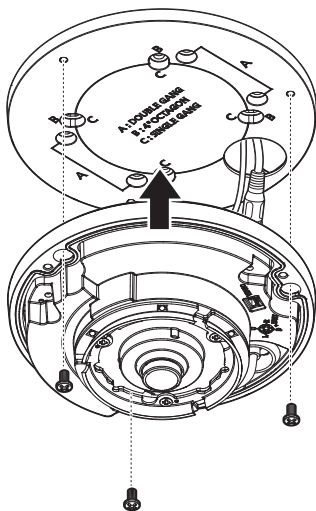

- When connecting cables from the side, first remove the wiring hole cover of the camera body.

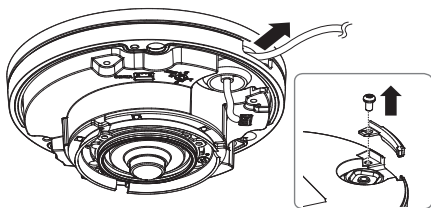

4. Assemble the dome cover.

- Make sure to firmly tighten the fastening screws so that there is no water damage issue.

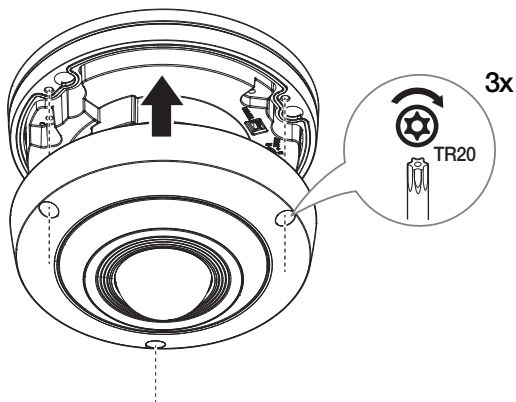

connection

CONNECTING TO MONITOR

Connect the Video OUT port on the rear panel of the camera to a ENCODER.

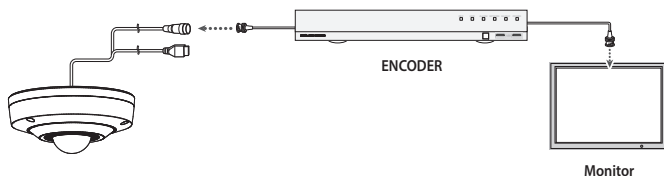

- As the connecting method varies with the instruments, refer to the manual supplied with the instrument.
- Only connect the cable when the power is turned off.



- This product supports 2 video output formats of AHD and CVBS. The default is AHD. Select the video output appropriate for your ENCODER.

- Video Cable

The camera's video output port is connected to the ENCODER with a BNC coaxial cable, shown below.

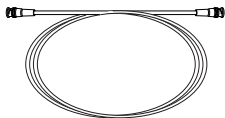

Distance	Recommended Cable Specification
300 m	5C2V



- It is recommended that pure copper coax cable is used and not copper coated steel, as this will cause issues with the communication over the coaxial cable.
- To ensure picture quality, only single-channel video output connector can be used while camera connected to other video equipments.

CONNECTING TO POWER

You can connect power as shown in the following figure.

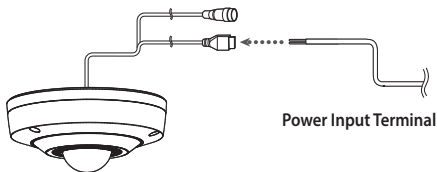

When the resistance value of copper wire is at [20°C(68°F)]

Copper wire size (AWG)	#24 (0.22 mm ²)	#22 (0.33 mm ²)	#20 (0.52 mm ²)	#18 (0.83 mm ²)
Resistance value(Ω/m)	0.078	0.050	0.030	0.018
Voltage Drop (V/m)	0.028	0.018	0.011	0.006

- As shown in the table above, voltage decreases as the wire gets longer. Therefore use of an excessively long adaptor output line for connection to the camera may affect the performance of the camera.
- ※ Standard voltage for camera operation : DC 12 V ± 10%, AC 24 V ± 10%
- ※ There may be some deviation in voltage drop depending on the type of wire and the manufacturer.



- Be sure to connect power only after all the installation is complete.

camera operation

MENU CONFIGURATION

MAIN SETUP			
VIDEO FORMAT	<ul style="list-style-type: none">• AHD	<ul style="list-style-type: none">• CVBS	
PROFILE	<ul style="list-style-type: none">• BASIC• ITS	<ul style="list-style-type: none">• USER• BACKLIGHT	<ul style="list-style-type: none">• INDOOR• DAY/NIGHT
SSDR	<ul style="list-style-type: none">• ON	<ul style="list-style-type: none">• OFF	
WHITE BAL	<ul style="list-style-type: none">• ATW• MANUAL	<ul style="list-style-type: none">• OUTDOOR• AWC → SET	<ul style="list-style-type: none">• INDOOR
EXPOSURE	<ul style="list-style-type: none">• BRIGHTNESS• SSNR4	<ul style="list-style-type: none">• SHUTTER• RETURN	<ul style="list-style-type: none">• AGC
BACKLIGHT	<ul style="list-style-type: none">• OFF• WDR	<ul style="list-style-type: none">• USER BLC	<ul style="list-style-type: none">• HLC
SPECIAL	<ul style="list-style-type: none">• DISPLAY• RETURN	<ul style="list-style-type: none">• IMAGE ADJ	<ul style="list-style-type: none">• DAY/NIGHT
EXIT	<ul style="list-style-type: none">• SAVE	<ul style="list-style-type: none">• RESET	<ul style="list-style-type: none">• NOT SAVE

CAMERA SETUP

Use the Function Setup switch within the camera.

VIDEO FORMAT

- From the Setup menu, select the <**VIDEO FORMAT**>.
- Select the VIDEO mode.
 - The video output can be selected from AHD/CVBS.

MAIN SETUP	
▶ 0. VIDEO FORMAT	AHD ◀↓
1. PROFILE	BASIC
2. SDDR	ON ◀↓
3. WHITE BAL	ATW
4. EXPOSURE	◀↓
5. BACKLIGHT	OFF
6. SPECIAL	◀↓
7. EXIT	SAVE



- By pressing the function setting switch for more than 5 seconds, you can change the setting from AHD to CVBS. From CVBS, you can change it to AHD.

PROFILE

- From the Setup menu, select the <**PROFILE**>.
- Select a desired mode.
 - BASIC** : The most common environment is set to meet.

MAIN SETUP	
0. VIDEO FORMAT	AHD ◀↓
▶ 1. PROFILE	BASIC
2. SDDR	ON ◀↓
3. WHITE BAL	ATW
4. EXPOSURE	◀↓
5. BACKLIGHT	OFF
6. SPECIAL	◀↓
7. EXIT	SAVE

- DAY/NIGHT** : It will be set automatically so it optimizes to the day or night conditions, respectively.
- BACKLIGHT** : It will be set automatically so you can distinguish the object from the background in a severe backlighting scene.
- ITS** : It will be set automatically so you can easily check the traffic conditions.
- INDOOR** : It will be set automatically to help you take a picture in a regular indoor lighting condition.

Camera operation

- **USER** : Automatically configures the camera to your custom settings.

- 1) Select Custom for Simple Setup mode.
- 2) Configure the menu options to your custom settings.
- 3) The settings are automatically saved as Custom mode.
- 4) Profile user mode don't initialize when menu resets.

3. In the PROFILE menu, you can configure the following camera settings at once.

	BASIC	DAY/NIGHT	BACKLIGHT	ITS	INDOOR	USER
SHUTTER	1/30~1/12000	1/30~1/12000	1/30~1/12000	1/200~1/12000	A.FLK	-
AGC	HIGH	HIGH	HIGH	HIGH	HIGH	-
WHITE BAL	ATW	ATW	ATW	OUTDOOR	INDOOR	-
BACKLIGHT	OFF	OFF	USER BLC	OFF	OFF	-
SSNR4	ON	ON	ON	ON	ON	-
DAY/NIGHT	AUTO	AUTO	AUTO	AUTO	AUTO	-



- If you select ITS mode, the shutter will be set to 1/200 sec. Noise can be detected at night.

SSDR

SSDR illuminates darker areas of an image while retaining the same light level for brighter areas to even out the overall brightness of images with high contrast between bright and dark areas.

1. From the Setup menu, select the <SSDR>.

2. To use SSDR, select <ON>.

- **Level** : As the level goes higher, a dark area becomes brighter.

MAIN SETUP	
0. VIDEO FORMAT	AHD ↵
1. PROFILE	BASIC
▶ 2. SSDR	ON ↵
3. WHITE BAL	ATW
4. EXPOSURE	↵
5. BACKLIGHT	OFF
6. SPECIAL	↵
7. EXIT	SAVE

Camera operation

EXPOSURE

1. From the Setup menu, select the **<EXPOSURE>**.
2. Select each item and set it properly.

- **BRIGHTNESS**: The brightness of the screen can be adjusted. The higher the number, the brighter the screen.
- **SHUTTER**: You can select the shutter.
 - MIN: 1~1/12000
 - MAX: 1/60~ 1/12,000
 - A.FLK: Select when you experience picture flicker, this happens when there is a clash with the installed lighting frequency.

MAIN SETUP	
0. VIDEO FORMAT	AHD ↵
1. PROFILE	BASIC
2. SDR	ON ↵
3. WHITE BAL	ATW
▶ 4. EXPOSURE	↵
5. BACKLIGHT	OFF
6. SPECIAL	↵
7. EXIT	SAVE



- The greater the shutter value the brighter the screen is but the more the residual images of objects there are.
- If the min shutter value is large, it can cause noise, spots and white areas but still operate normally.
- Depending on the setting range of the minimal/maximal shutter, the screen exposure can become saturated.

- **AGC (OFF/LOW/MIDDLE/HIGH)**:
The higher the gain level, the brighter the screen - but the greater the noise.

- **SSNR4**: Remove noise from the image. When **<ON>** is selected, the SSNR4 level can be adjusted.



- When adjusting the noise reduction level in the SSNR4 mode, remember that the higher the level set, the more the noise level will be reduced, as will the brightness of the image.

BACKLIGHT

The camera uses high performance DSP chips that are designed to clearly display the object and the background despite severe reverse light.

1. From the Setup menu, select the **<BACKLIGHT>**.
2. Select the desired mode.

MAIN SETUP	
0. VIDEO FORMAT	AHD ↵
1. PROFILE	BASIC
2. SDR	ON ↵
3. WHITE BAL	ATW
4. EXPOSURE	↵
▶ 5. BACKLIGHT	OFF
6. SPECIAL	↵
7. EXIT	SAVE

- **USER BLC :**

Enables a user to select a desired area on a picture and view that area more clearly.

- LEVEL : Adjusts the brightness level of a monitoring area.
- TOP/BOTTOM/LEFT/RIGHT: Adjust the area to be enhanced.
- DEFAULT: Resets the USER BLC setting.
- RETURN : Return to the MAIN SETUP menu.

USERBLCSETUP	
▶ 1. LEVEL	MIDDLE
2. TOP	30 ■■■■■■■■■■
3. BOTTOM	75 ■■■■■■■■■■
4. LEFT	30 ■■■■■■■■■■
5. RIGHT	75 ■■■■■■■■■■
6. RETURN	↵

- **HLC (High Light Compensation) :**

The HLC (High Light Compensation) mode blocks strong lighting such as a streetlight or the headlights of a vehicle, to prevent failures to detect a neighboring object, such as a car license plate, due to saturation of strong lights.

- LEVEL : Adjusts the brightness level of a monitoring area.
- LIMIT : Enable to change the operating condition.
- MASK COLOR : Sets the color of the blocked area.
- TOP/BOTTOM/LEFT/RIGHT : Adjust the area to be enhanced.
- RETURN : Return to the MAIN SETUP menu.

HLC SETUP	
▶ 1. LEVEL	MIDDLE
2. LIMIT	NIGHT ONLY
3. MASK COLOR	BLACK
4. TOP	30 ■■■■■■■■■■
5. BOTTOM	75 ■■■■■■■■■■
6. LEFT	30 ■■■■■■■■■■
7. RIGHT	75 ■■■■■■■■■■
8. RETURN	↵

Camera operation



- At night, it only operates when the size of a highlight goes over the threshold in a dark environment.
- At night, HLC does not operate when it is overall too bright or dark. In daytime, HLC does not operate when it is too dark.

• WDR

When there are both bright and dark areas at the same time, this mode makes both areas distinctive.

- LEVEL : Select one from low, middle, high to adjust the brightness of the WDR setup.

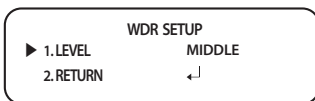

<WDR ON>



<WDR OFF>

- RETURN : Return to the MAIN SETUP menu.

SPECIAL

1. From the Setup menu, select the <SPECIAL>.
2. Select each item and set it properly.

● DISPLAY

- ① Select <DISPLAY>.
- ② Set the following items.

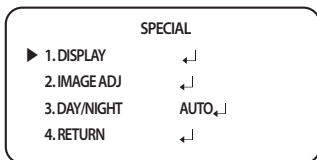

- CAM TITLE

- ① Use the Function Setup switch to move to a desired letter and select the letter by pressing the Function Setup switch. Repeat this to enter multiple letters. You can enter up to 15 letters.
- ② Enter a title, move the cursor to 'POS' and press the Function Setup switch. The entered title appears on the screen. Select the position to display the title on the screen by using the Function Setup switch and press the Function Setup switch. When the position is determined, select 'END' and press the Function Setup switch to return to the DISPLAY menu.

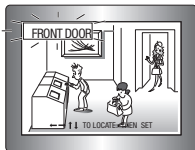
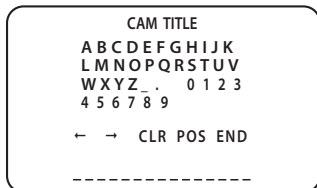

- FONT COLOR : You can change the OSD font color. (White, Yellow, Green, Red, Blue)
- LANGUAGE : Only english can be used with this unit.
- RETURN : Return to the SPECIAL menu.

Camera operation

• IMAGE ADJ

① Select <IMAGE ADJ>.

② Set the following items.

- GAMMA : The setting range is 0.20 ~ 1.0. The closer to 1.0 the setting is, the darker it gets.
- PED LEVEL : The setting range is 1 ~ 100. The closer to 100 the setting is, the higher the PED level gets.
- COLOR GAIN : The setting range is 1 ~ 100. The smaller the setting value is the smaller the color gain gets and the more color blind it gets.
- MIRROR
 - MIRROR : Flip an image horizontally.
 - V-FLIP : Flip an image vertically.
 - ROTATE : Rotates the video captured by the camera according to the set angle.
- D-ZOOM : Users can set the level in order to enlarge a subject in the central area of video image, and it can be set by users. The default setting is "1.0X". The level varies 1.0X(no enlargement) to 16.X(max enlargement), and can be set among 150 levels by users.
- SHARPNESS : Adjust the overall sharpness of the image. The higher the sharpness level is, the stronger and clearer the video sharpness is. The setting range is 1 ~ 32.
- RETURN : Return to the SPECIAL menu.

IMAGE ADJ	
▶ 1. GAMMA	0.45
2. PED LEVEL	30 ■■■■■■■■■■■■■■■■■■■■
3. COLOR GAIN	50 ■■■■■■■■■■■■■■■■■■■■
4. MIRROR	OFF
5. D-ZOOM	OFF
6. SHARPNESS	ON_↓
7. RETURN	←



- If you increase the SHARPNESS level too high, the picture may become distorted or noise may appear.

- **DAY/NIGHT:** You can display pictures in color or in black and white.

① Select <DAY/NIGHT>.

② Select the desired mode.

- **AUTO :** Switch to color mode during the daytime and b/w at night or in low light.

DAY/NIGHT	
▶ 1. BURST	ON
2. DURATION	NORMAL
3. DWELL TIME	3 SEC
4. RETURN	←

- **BURST :** Activate or deactivate the burst mode to maintain or remove the color signal.
- **DURATION :** This function is used to select the brightness of light where switching occurs.
- **DWELL TIME :** You can select day/night switching delay time from.
→ 3s, 5s, 7s, 10s, 15s, 20s, 30s, 40s, 60s



- If you set the AGC mode to off on the exposure menu, you cannot switch the day/night mode to auto.
- When a bright light source is in the screen or there are frequent brightness changes, if you use the auto night/day mode, and set the switching time to short (3, 5 sec), a hunting can be caused. In this situation, it is recommended to use the default setting (30 sec).
- **COLOR :** The picture is always displayed in color.
- **B/W :** The picture is always displayed in black and white.
You can turn on or off the burst signal on B/W mode.
 - **IR MODE :** When IR LED is turned on in the B/W mode, the saturation at the center of the screen will be prevented depending on the set screen size so that the camera can identify a subject even at a close distance.
- **RETURN :** Return to the SPECIAL menu.

Camera operation

EXIT

- **SAVE** : Save the current settings and exit the MAIN SETUP menu.
- **NOT SAVE** : Do not save the current settings and exit the MAIN SETUP menu.
- **RESET** : Revert camera to factory settings.

troubleshooting

TROUBLESHOOTING

If you have trouble operating your camera, refer to the following table.

If the guidelines do not enable you to solve the problem, contact an authorized technician.

Problems	Troubleshooting
Nothing appears on the screen.	<ul style="list-style-type: none">• Check that the power cord and line connection between the camera and monitor are properly connected.• Check that you have properly connected BNC cable to the camera.• Check the type of lens.
The image on the screen is dim.	<ul style="list-style-type: none">• Is lens stained with dirt? Clean your lens with soft, clean cloth.• Set the monitor or DVR to the proper condition.• If the camera is exposed to very strong light, change the camera position.
The image on the screen is dark.	<ul style="list-style-type: none">• Adjust the contrast feature of the monitor or encoder.• If you have an intermediate device, set the 75Ω / Hi-z properly.
The camera is not working properly, and the surface of the camera is hot.	<ul style="list-style-type: none">• Check that you have properly connected the camera to an appropriate power source.
he DAY/NIGHT menu does not work.	<ul style="list-style-type: none">• Check that AGC of EXPOSURE SETUP menu is 'OFF'.
Color is not correct.	<ul style="list-style-type: none">• Check the setting of WHITE BAL SETUP menu
The screen flickers continually.	<ul style="list-style-type: none">• Ensure the camera is not pointing towards the sun.

