

OSM-2400_Manual_230113

Cypress OSM-2400 Manual - Product Overview & Specifications

The OSM-2400 is an upgraded replacement for the OSM-1000 Wiegand-OSDP converter. The OSM-2400 is used to connect an OSDP reader to a Wiegand controller, or used to connect a Wiegand reader to an OSDP controller. This allows users to begin adopting OSDP and gaining the benefits, such as encrypted communication, without having to replace the entire system. The OSM-2400 supports LED, Buzzer, and Relay Output I/O. DIP switches provide options for manually setting the device address, selecting different modes for I/O behavior, and selecting the ACU or PD operating modes.

It is recommended to maximize the OSDP run between the reader and the controller to provide the most secure connection. When connecting an OSDP reader to a Wiegand controller, it is best to install the OSM-2400 near the Wiegand controller. When connecting a Wiegand reader to an OSDP controller, it is best to install the OSM-2400 near the Wiegand reader.

Specifications

Part Number	Part Number	OSM-2400	
	UPC	816684006128	
Physical	Physical Dimensions (L x W x H)	4.03 x 1.50 x 0.45 inches 10.24 x 3.81 x 1.14 cm	
	Weight	1 oz. 28.35 grams	
Environmental	Operating Temperature Range	-40°F to 158°F -40°C to 70°C	
	Enclosure Rating	No Enclosure, not rated for water or dust intrusion	
Electrical	Supply Voltage	8 - 16 VDC (12 VDC Typical) @ 250 mA Max	
	Relay	Max Switching	220Vdc 30W (resistive) 1A / 250Vac 37.5VA 1A
		Running Spec with load	30Vdc 1A (resistive) / 125 Vac 0.3A (resistive), 1x10 ⁵ operations @ 20°C
Additional Features	Connect OSDP reader to Wiegand panel, or connect Wiegand reader to OSDP panel.		
	Supports Secure Channel Protocol for encrypted communication.		
	Supports firmware update with OSDP File Transfer.		
	Supports Wiegand readers and controllers with one or two LED control lines.		
	Use DIP switches to select OSDP device addresses 0-7. Device addresses 0-126 supported.		
	Supported baud rates: 9600, 19200, 38400, 57600, 115200, 230400.		
	Relay Output for tamper/supervision (ACU Mode) or general output (PD Mode).		
	Power inputs available on both headers, with passthrough (only use one at any given time).		

Related Products (sold separately)

OTT-2100	Pocket-sized OSDP COMSET Tool	Configure device address and baud rate without knowing current settings, and can be used to default the SCBK.
-----------------	-------------------------------	---

Cypress OSM-2400 Manual - Table of Contents

Table of Contents	
<i>Topic</i>	<i>Page</i>
Overview and Specifications	2
OSDP Terminology	4
Using ACU Mode or PD Mode	5
Physical Features & Dimensions	6
Pin Designations	7
Power Input	8
ACU Mode Wiring Diagram	9
PD Mode Wiring Diagram	10
General OSDP Communication Information	11
PD Capability Report (PD CAP)	12-13
Status LED	14
DIP Switches	15-17
LED Modes	18-19
Using Secure Channel Communication	20-22
ACU Mode I/O Overview	23-24
ACU Mode LED Commands - Red LED Input	25
ACU Mode LED Commands - Green LED Input	26
ACU Mode LED Commands - Amber LED Input	27
ACU Mode LED Commands - OFF LED Input	28
ACU Mode LED Commands - Buzzer Input	29
PD Mode I/O Overview	30-31
PD Mode I/O - Wiegand Output	32
Firmware Upload Using File Transfer	33

Cypress OSM-2400 Manual - OSDP Terminology

This section lists and defines in general terms OSDP terminology used in this manual.

Access Control Unit (ACU): Typically the access controller, the ACU is the device on the OSDP bus that controls the PDs. The ACU only sends commands to the PDs and waits for replies.

Peripheral Device (PD): Typically a reader, but many other devices can be PDs, any device on the OSDP bus that is not the ACU. PDs receive commands from the ACU and send replies.

Device Address: OSDP Peripheral Devices are assigned an address, all PDs on the OSDP bus must have a unique address. This address is used in commands from the ACU and in replies from the PD to indicate which device the message is being sent to/from.

Baud Rate: Data transfer rate, expressed in bits per second. Communication speed between ACU and PD(s).

Secure Channel Base Key (SCBK): 16 byte key set by the user used to initiate Secure Channel communication sessions.

Secure Channel Base Key Default (SCBK-D): Default SCBK value. Default value set by the manufacturer or the default value defined in the OSDP specification.

Secure Channel Session: OSDP communication sessions using the Secure Channel Protocol, which, among other things, encrypts the data payload in OSDP messages.

Unencrypted Communication Session: OSDP communication sessions without data payload encryption.

File Transfer: OSDP protocol used to transfer a file from the ACU to the PD. In the case of the OSM-2400, a firmware file.

NAK: Negative acknowledge reply from the PD. Indicates the PD had an error processing the previous command or is incapable of processing the previous command.

ACK: Positive acknowledge reply from the PD. The PD properly processed the previous command or nothing to report to ACU.

RAW: PD reply with card data payload. Card data is a raw string of bits.

Manufacturer Specific Command: OSDP Command implemented by the manufacturer for special device functions not found in the OSDP spec.

Cypress OSM-2400 Manual - Using ACU Mode or PD Mode

ACU Mode (Access Control Unit)

ACU Mode is used to connect an OSDP reader to a Wiegand access controller. The OSM-2400 is in ACU Mode when DIP switch 8 is ON. Application: Install OSDP readers in a legacy Wiegand access system and enable Secure Channel encryption to protect high security areas.

The OSM-2400 controls the OSDP reader. Credential data read by the OSDP reader is sent to the OSM-2400 over the OSDP connection, then the OSM-2400 sends the credential data to the Wiegand port over the Wiegand data lines. The I/O lines (LED and Buzzer) on the OSM-2400 are connected to the Wiegand port. When the Wiegand access controller changes the state of the I/O lines, the OSM-2400 translates the state of the I/O lines into OSDP commands that are sent to the OSDP reader.

The OSM-2400 supports one OSDP reader. The device address and baud rate must be the same between the OSM-2400 and OSDP reader for proper OSDP communication to be achieved. The OSM-2400 device address is set by DIP switches 1-3 or by the `osdp_COMSET` command (while in PD Mode). The baud rate is set by the `osdp_COMSET` command (while in PD Mode).

PD Mode (Peripheral Device)

PD Mode is used to connect a Wiegand reader to an OSDP access controller. The OSM-2400 is in PD Mode when DIP switch 8 is OFF. Application: Support legacy Wiegand readers on an OSDP access control system.

The OSM-2400 is controlled by the OSDP access controller. Credential data read by the Wiegand reader is sent to the OSM-2400 over the Wiegand data lines, then the OSM-2400 sends the credential data to the OSDP access controller over the OSDP connection. The OSDP access controller sends the OSM-2400 OSDP I/O commands (LED, Buzzer, and Relay Output). The OSM-2400 controls the Wiegand reader by changing the state of its physical I/O according to the OSDP commands.

The OSM-2400 can be one of multiple PDs on the OSDP bus. The OSM-2400 will need to have a unique device address (set with DIP switches 1-3 or by the `osdp_COMSET` command) and the baud rate will need to match the baud rate of the OSDP access controller.

Cypress OSM-2400 Manual - Physical Features & Dimensions

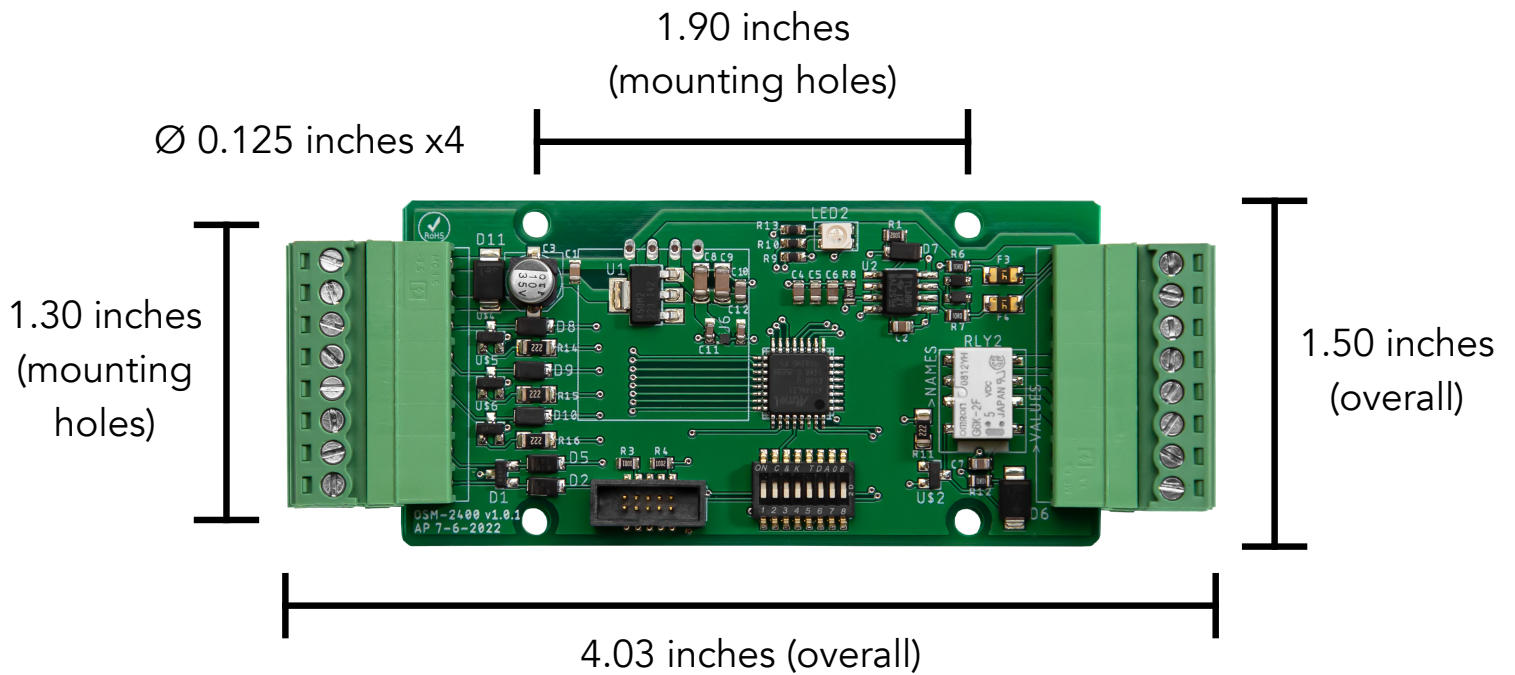
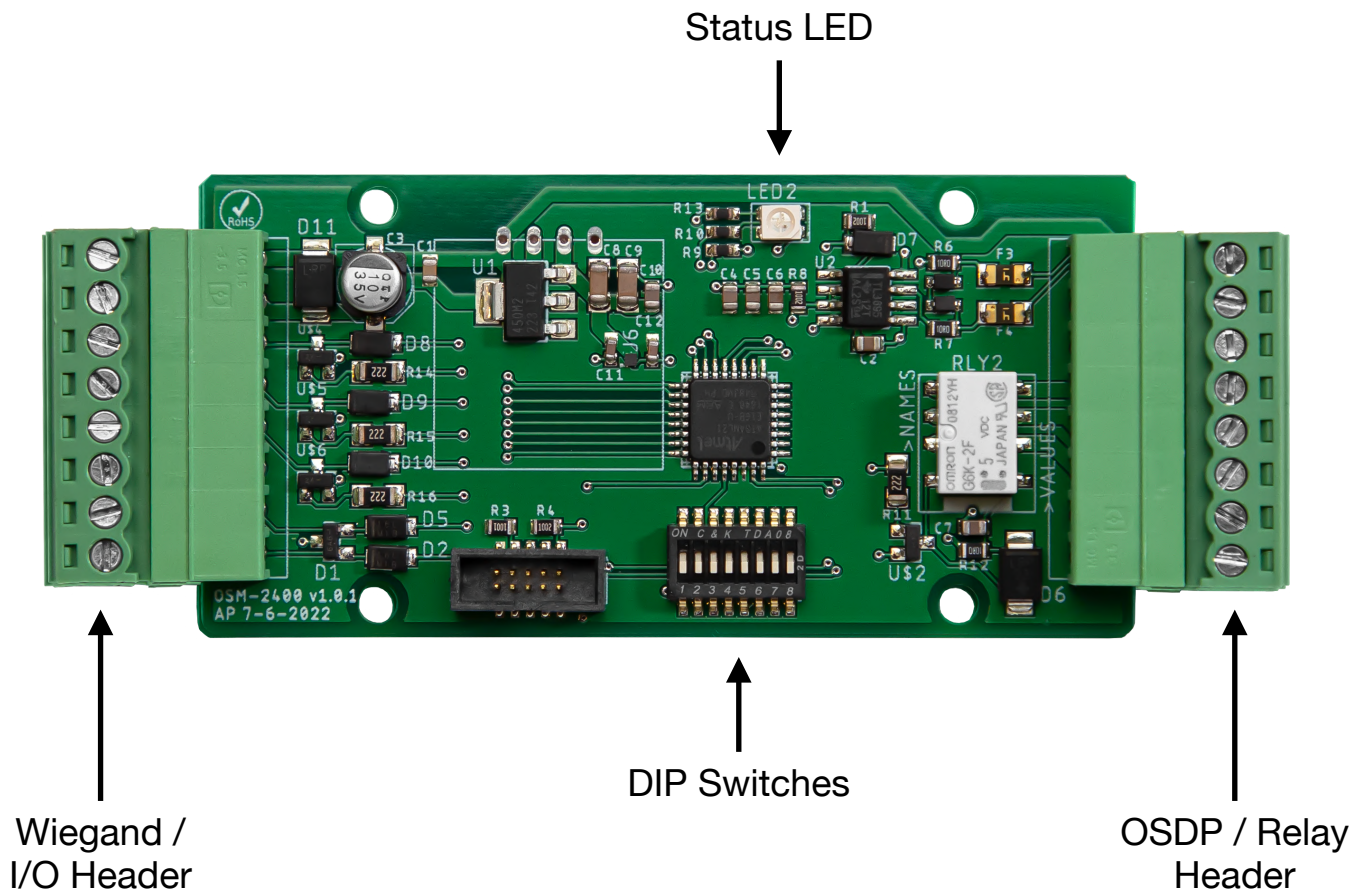

ACU Mode Pin Designations

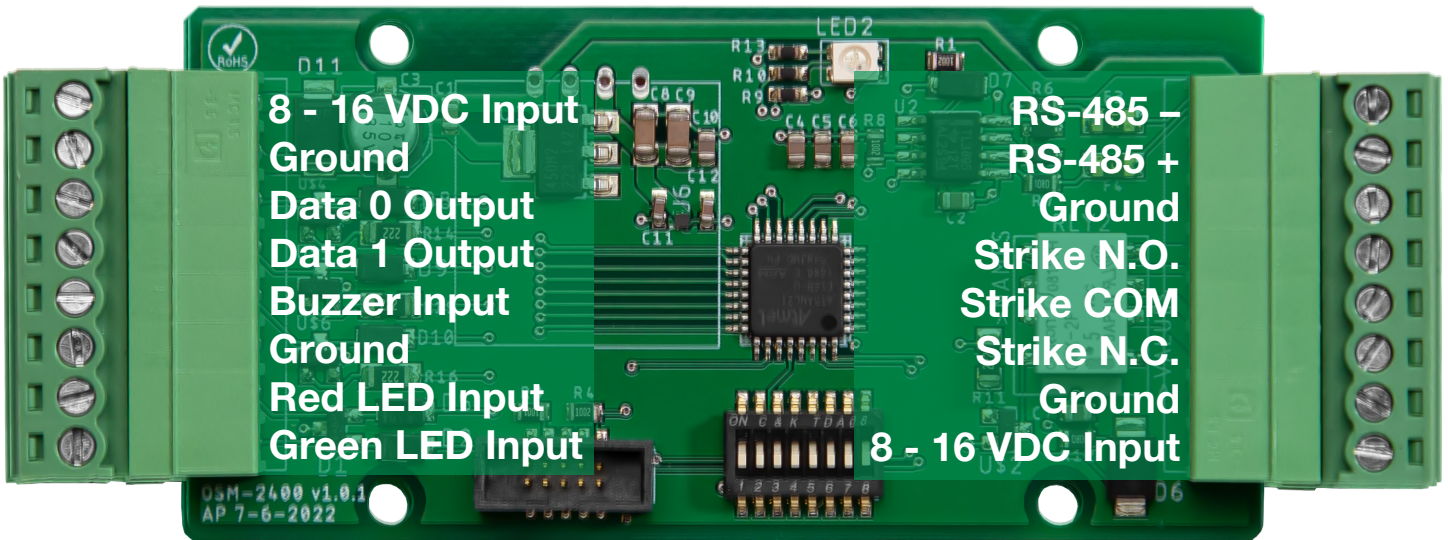

PD Mode Pin Designations

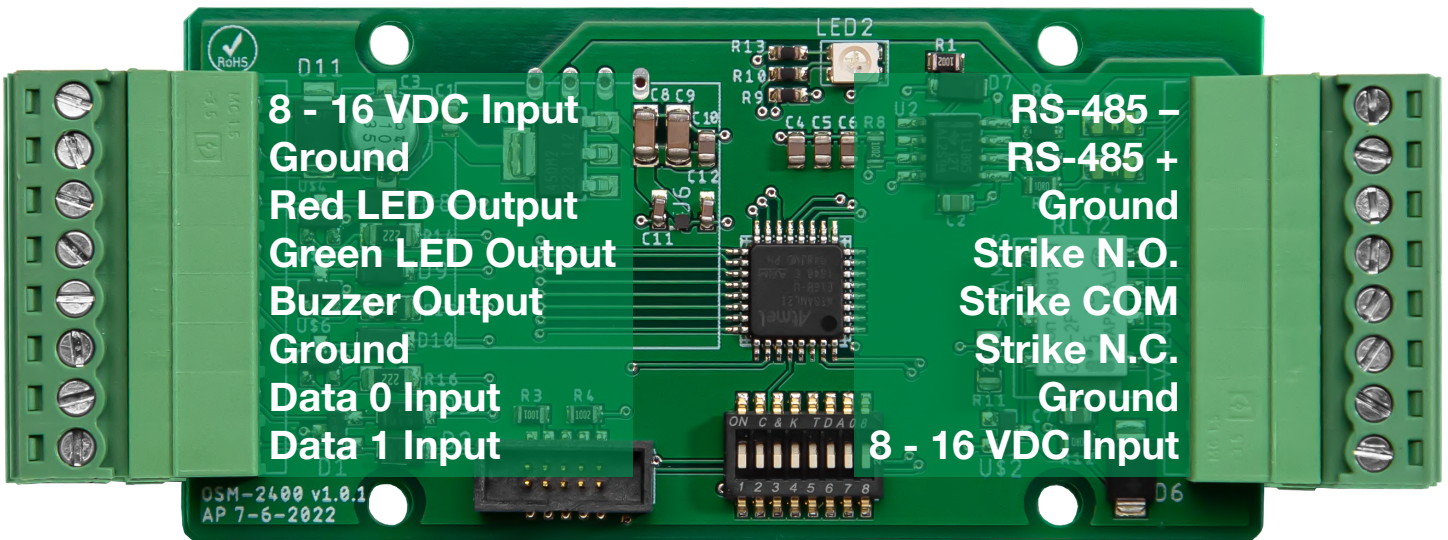

Cypress OSM-2400 Manual - Power Input

The OSM-2400 is powered with 8 to 16 VDC (12 VDC typical) for the power input, and draws at most 250 mA of current. There are two power inputs that are connected together (common), shown in green text in the diagram below. The OSM-2400 can be powered by either power input, but not both. Power can be passed through the OSM-2400 because the power inputs are common. Other devices can be powered with the power input not connected to the power supply, provided power supply can provide enough power for all devices.

The four Ground pins (two on each header) are all common.

IMPORTANT: DO NOT power the OSM-2400 with multiple power supplies. Doing so can cause damage to the OSM-2400 and/or the power supplies.

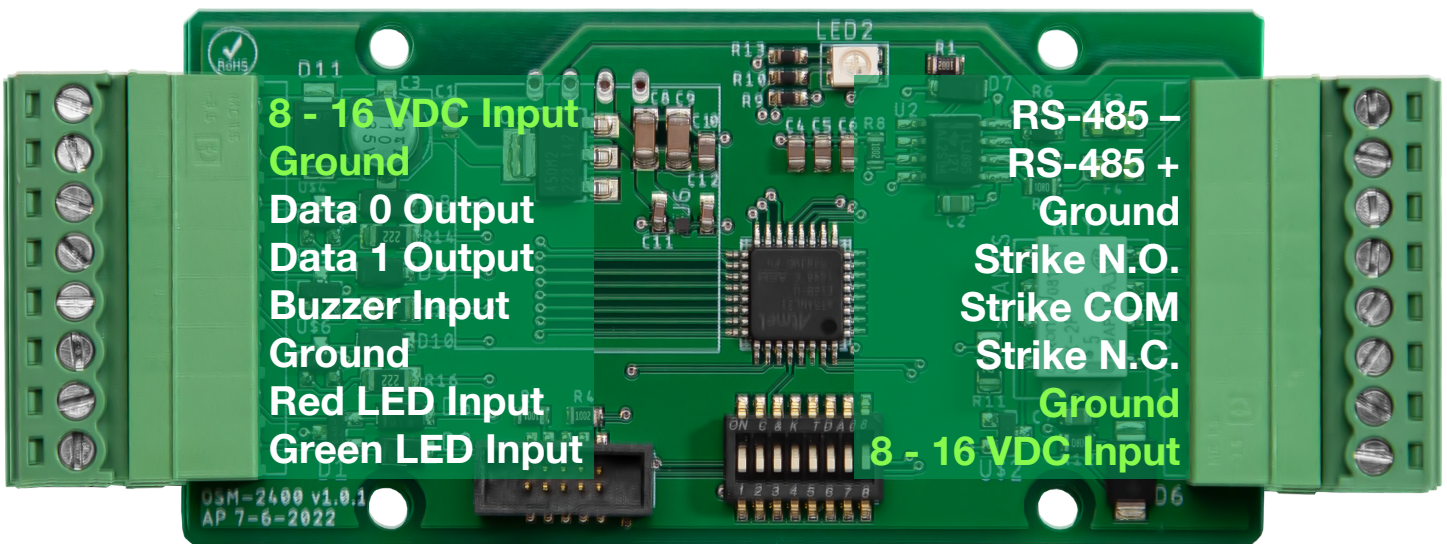

Cypress OSM-2400 Manual - ACU Mode Wiring Diagram

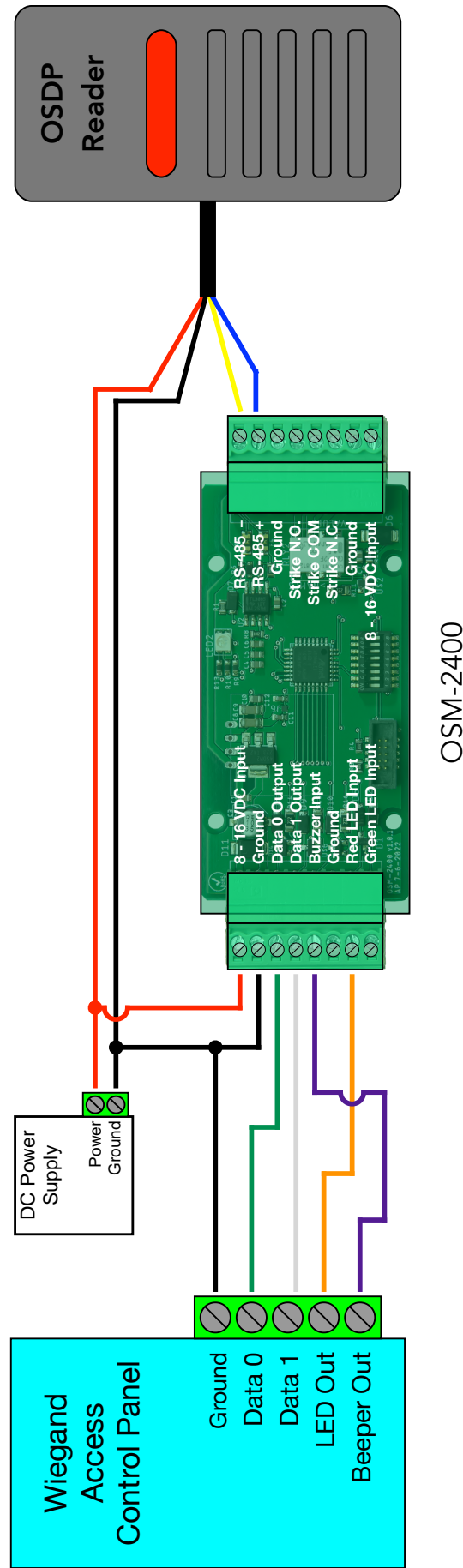

This wiring diagram shows the OSM-2400 in Single LED Mode (DIP Switch 4 ON) connecting to a Wiegand access controller with a single LED output.

If the Wiegand access controller being used has two LED outputs then the OSM-2400 should be used in Dual LED Mode (DIP Switch 4 OFF). The two LED outputs should be connected to the Red LED Input and Green LED Input on the OSM-2400.

Cypress OSM-2400 Manual - PD Mode Wiring Diagram

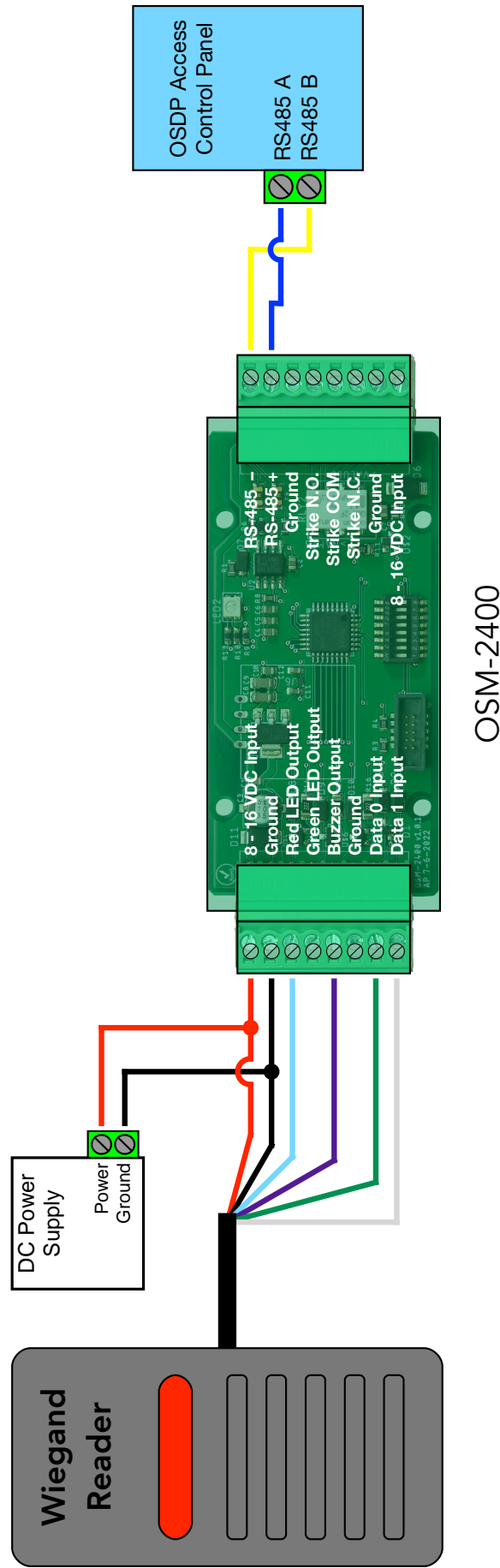

This wiring diagram shows the OSM-2400 in Single LED Mode (DIP Switch 4 ON) connecting to a Wiegand reader with a single LED control line.

If the Wiegand reader being used has two LED control lines then the OSM-2400 should be used in Dual LED Mode (DIP Switch 4 OFF). The two LED control lines should be connected to the Red LED Output and Green LED Output on the OSM-2400.

Cypress OSM-2400 Manual - General OSDP Communication Information

Supported Device Addresses

The OSM-2400 supports device addresses 0-126. Device addresses 0-7 can be set using DIP switches 1-3. In ACU Mode (Access Control Unit), the OSM-2400 device address is the address the OSM-2400 will use to poll the OSDP reader or PD. In PD Mode (Peripheral Device), the device address is the address the OSM-2400 will respond to the ACU on.

Supported Baud Rates

The OSM-2400 supports 6 communication baud rates: 9600, 19200, 38400, 57600, 115200, and 230400. The communication baud rate is set by sending the `osdp_COMSET` command to the OSM-2400 in PD Mode. The OSM-2400 default baud rate is 9600.

Message Timeout

The message timeout is 200 milliseconds, as defined in the OSDP specification.

In ACU Mode, the OSM-2400 will resend the command if it does not receive a reply from the OSDP reader or PD within 200ms.

Session Timeout

The OSDP session timeout is 8 seconds, as defined in the OSDP specification.

In ACU Mode, if the OSM-2400 does not receive a reply from the PD within 8 seconds it will end the OSDP communication session. A new OSDP communication session will be established in order for communication to resume.

In PD Mode, if the OSM-2400 does not receive a command from the ACU within 8 seconds it will end the OSDP communication session. A new OSDP communication session needs to be established in order for communication to resume.

Cypress OSM-2400 Manual - Device Capabilities Report (PDCAP)

ACU Mode (Access Control Unit)

The OSM-2400 in ACU Mode does not send the osdp_CAP command to the connected OSDP reader or PD to read its capabilities. The OSM-2400 will send the PD any control and I/O commands based on the state of the DIP switches and inputs controlled by the Wiegand access controller. If the OSDP reader or PD does not support the I/O command sent by the OSM-2400 it should reply with a NAK.

PD Mode (Peripheral Device)

The ACU can command the PD (OSM-2400) to provide a list of its device capacities, this is called the Device Capabilities Report, or PDCAP. The PDCAP includes information about supported credential formats/length, supported I/O, communication security, and more. The ACU sends the osdp_CAP command and the PD replies with the osdp_PDCAP reply.

The osdp_PDCAP reply data field contains the information about the device's capabilities. The data field is made up of multiple 3 byte sections for each capability. Each 3 byte section has three, one byte fields; Function Code, Compliance, and Number Of.

The OSM-2400 (PD Mode) osdp_PDCAP reply data field is below in HEX (Dual LED Mode):

```
02 03 01 03 01 00 04 03 01 05 02 01 08 01 00 09 01 01 0A A0 05 0B 00 80 10 02 00
```

The data field contains 10, 3 byte capability sections (30 bytes total). The table below and the table on the following page break down these 3 byte capability sections by field and explain the meaning of each.

Field Value	Meaning
Function Code: 02	Output Control
Compliance: 03	Output Supports Timed Control
Number of: 01	Device has 1 Output
Function Code: 03	Card Data Format
Compliance: 01	Device Supports RAW Replies up to 1024 Bits
Number of: 00	N/A
Function Code: 04	LED Control (Single LED Mode)
Compliance: 03	Bi-Color LED with Timed Control
Number of: 01	Device has 1 LED

Cypress OSM-2400 Manual - PD Capability Report (PD CAP) (Cont.)

Field Value	Meaning
Function Code: 04	LED Control (Dual LED Mode)
Compliance: 04	Tri-Color LED with Timed Control
Number of: 01	Device has 1 LED
Function Code: 05	Audio Output
Compliance: 02	Audio Output Supports Timed Control
Number of: 01	Device has 1 Audio Output (Buzzer Output)
Function Code: 08	Check Character Support
Compliance: 01	CRC-16 is Supported
Number of: 00	N/A
Function Code: 09	Communication Security
Compliance: 01	AES128
Number of: 01	Device Uses OSDP Default Key
Function Code: 0A	Maximum Single Message Size (for File Transfer Protocol)
Compliance: A0	The size capabilities are calculated by adding the values in the Compliance and Number Of fields. Device supports a maximum receive buffer size of 1440 bytes.
Number of: 05	
Function Code: 0B	Maximum Multi-Part Message Size (for File Transfer Protocol)
Compliance: 00	The size capabilities are calculated by adding the values in the Compliance and Number Of fields. Device supports a maximum file size of 32kB.
Number of: 80	
Function Code: 10	OSDP Specification Compliance
Compliance: 02	Device Supports OSDP Version 2.2
Number of: 00	N/A

Cypress OSM-2400 Manual - Status LED

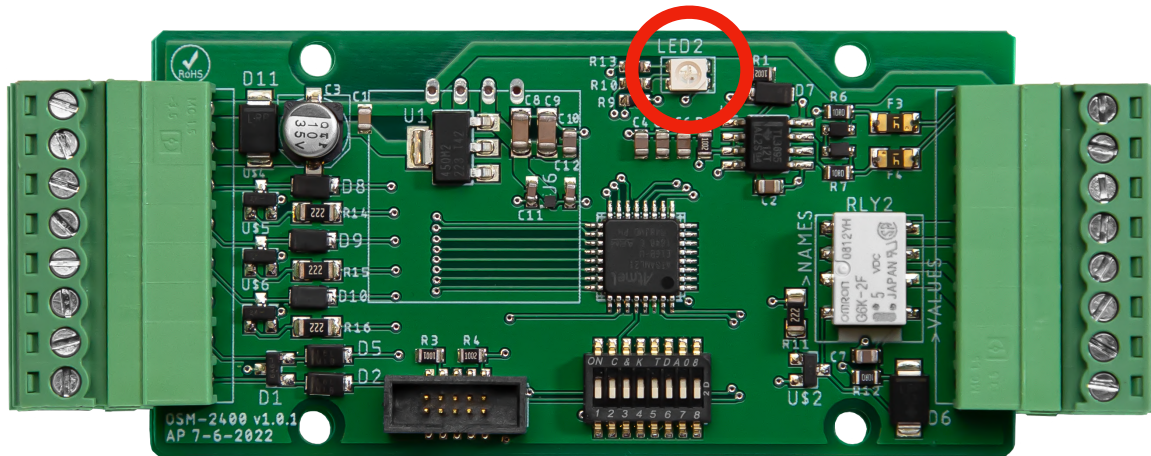

The OSM-2400 has a single tri-color LED that displays Red, Green, Blue, and White to indicate the state of the OSDP communication session.

ACU Mode Status LED States:

Flashing RED: Attempting to poll PD with selected address

Flashing BLUE: Unencrypted communication session with PD

Flashing GREEN: Secure Channel communication session with PD

Single WHITE Flash: Card or keypad data received from OSDP card reader and Wiegand Data output to access controller

PD Mode Status LED States:

Solid RED: No communication from ACU

Flashing RED: The OSM-2400 detects valid OSDP communication on the bus, but the OSM-2400 is not being polled by the ACU

Flashing BLUE: Unencrypted communication session with ACU

Flashing GREEN: Secure Channel communication session with ACU

Single WHITE Flash: Card or keypad data received from Wiegand card reader and RAW reply sent to ACU

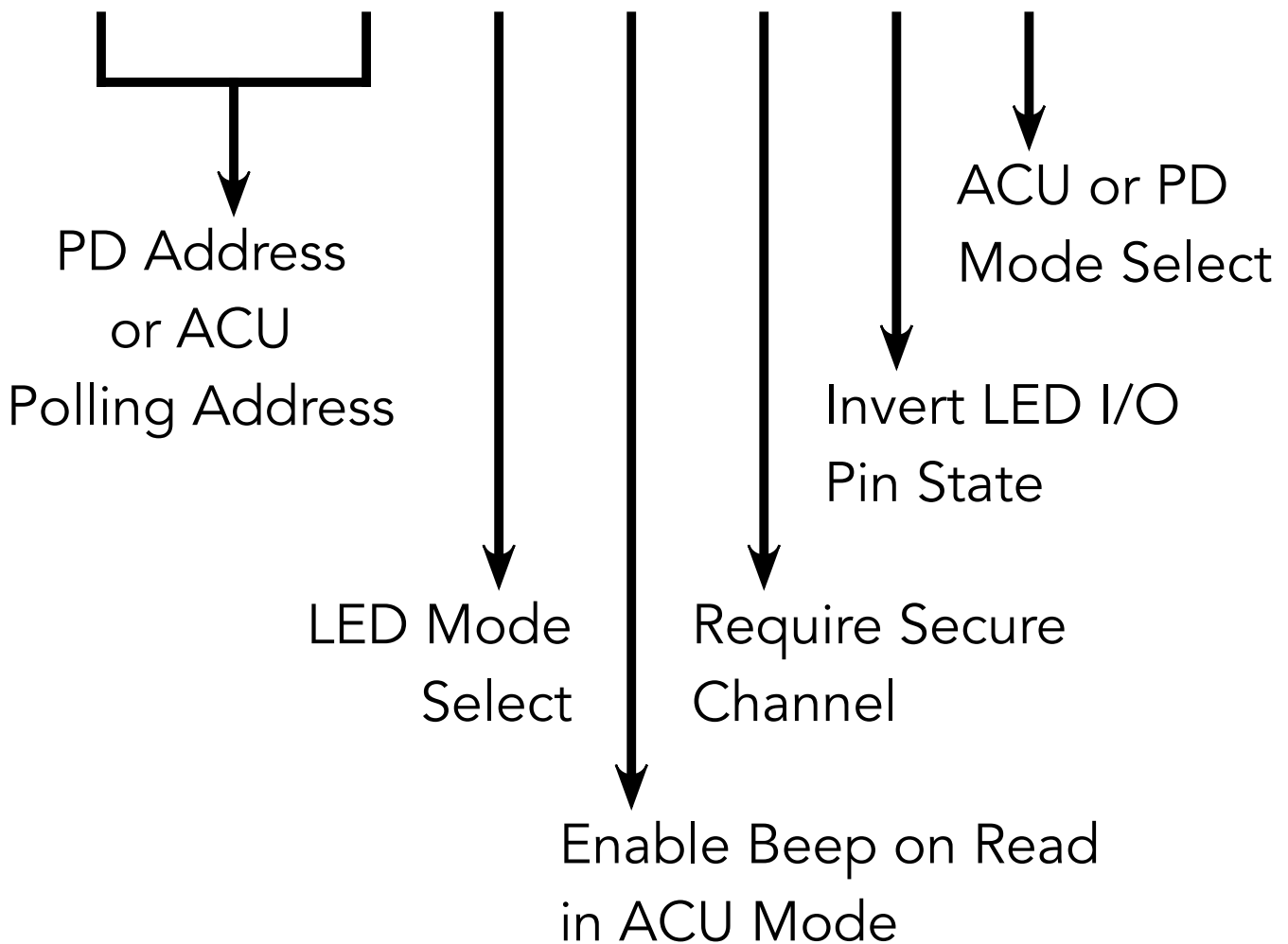
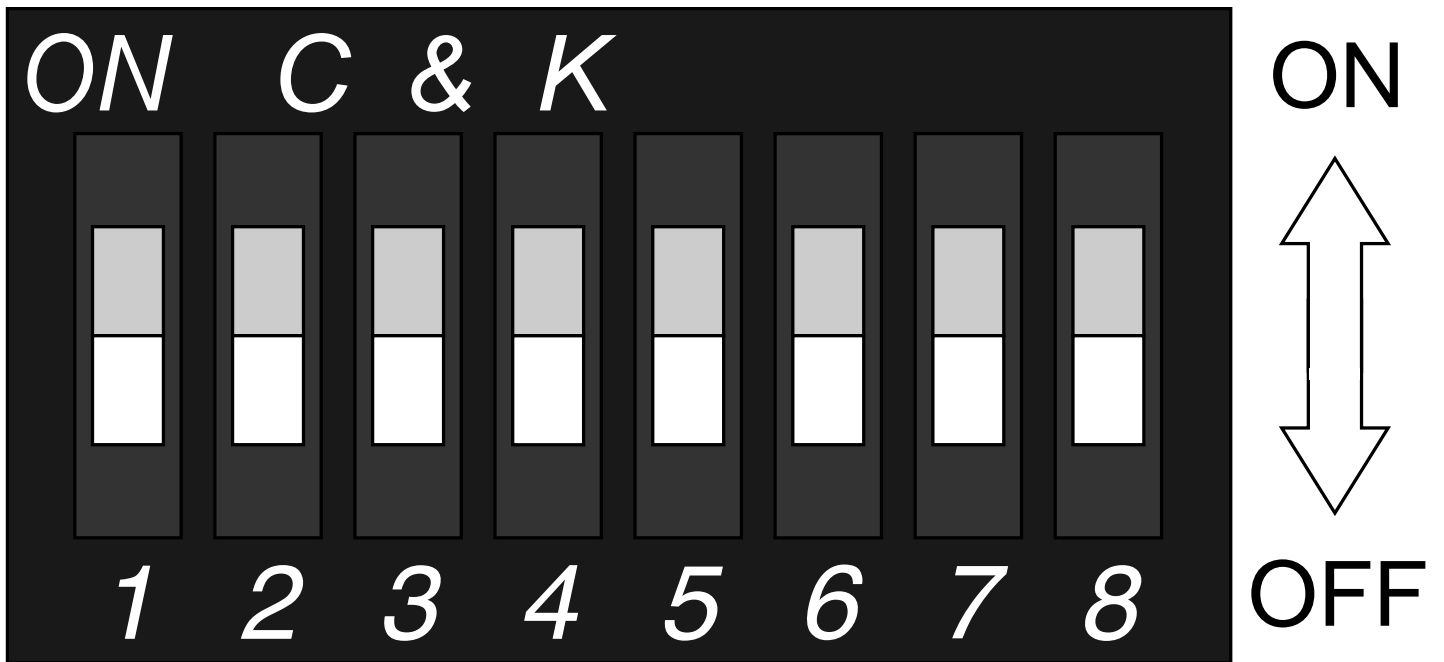

Cypress OSM-2400 Manual - DIP Switches (Cont.)

DIP Switches 1-3 - Selecting PD Address or ACU Polling Address:

DIP Switches 1-3 are used to set the OSDP address of the OSM-2400 in PD Mode (Peripheral Device), and to set the OSDP address the OSM-2400 will poll in ACU Mode (Access Control Unit). Addresses 0-7 are able to be selected using the DIP Switches, see the table below.

Other addresses can be set by sending the OSM-2400 the `osdp_COMSET` command while in PD Mode. DIP Switches 1-3 need to all be OFF for the new address to be used. When DIP switches 1-3 are OFF, the OSM-2400 will check if any address has been set by the `osdp_COMSET` command. If an address has been set by the `osdp_COMSET` command that address will be used. If no address has been set by the `osdp_COMSET` command, address 0 will be used. When DIP Switches 1-3 are set to any address 1-7, those addresses will override any address set by the `osdp_COMSET` command.

Below is a table showing how DIP switches 1-3 are set to select the address.

Switch / Address	1	2	3
0 / configurable			
1	X		
2		X	
3	X	X	
4			X
5	X		X
6		X	X
7	X	X	X

X = ON

DIP Switch 4 - LED Mode Select:

DIP Switch 4 is used to select the LED mode. When DIP Switch 4 is OFF, the OSM-2400 is in Dual LED Mode, for use with Wiegand readers or controllers with 2 LED lines. In Dual LED Mode both the Red and Green LED lines are enabled and there are 4 possible LED states; RED, GREEN, AMBER, and OFF.

When DIP Switch 4 is ON, the OSM-2400 is in Single LED Mode, for use with Wiegand readers or controllers with a single LED line. In Single LED Mode the Red LED line is enabled and the Green LED line is disabled. When the Red LED line is in the normal state the LED state is RED, when the Red LED line is in the active state the LED state is GREEN.

Cypress OSM-2400 Manual - DIP Switches (Cont.)

DIP Switch 5 - Enabling Beep on Read:

When DIP Switch 5 is ON and the OSM-2400 is in ACU mode, every time the OSM-2400 receives card or keypad data it will also send the OSDP reader (PD) the osdp_BUZZ command with a 500 ms (0.5 second) activation time.

DIP Switch 5 has no function in PD Mode.

DIP Switch 6 - Require Secure Channel Communication:

In PD Mode, when DIP Switch 6 is ON, the OSM-2400 will only reply to attempts by the ACU to start a Secure Channel communication session. The OSM-2400 will reply to all other commands sent by the ACU in clear channel with a NAK. Once a Secure Channel session is established, the OSM-2400 will behave as a normal PD.

In ACU Mode, when DIP Switch 6 is ON, the OSM-2400 will only attempt to start a Secure Channel session with the PD. Once a Secure Channel session is established, the OSM-2400 will behave as a normal ACU.

DIP Switch 7 - Invert LED I/O Pin State:

When DIP switch 7 is ON, the states of the LED lines will be inverted, making the LED lines active high digital inputs. The active state is high (5V) and the normal state is low (0V).

DIP Switch 8 - ACU Mode / PD Mode Select:

When DIP switch 8 is ON the OSM-2400 will operate in ACU Mode. When DIP switch 8 is OFF the OSM-2400 will operate in PD Mode.

Cypress OSM-2400 Manual - LED Modes

The OSM-2400 supports two LED modes which are used to support different types of LED control in OSDP readers or ACUs (Access Control Unit). The LED mode is selected with DIP Switch 4. When DIP Switch 4 is OFF the OSM-2400 is in Dual LED Mode. When DIP Switch 4 is ON the OSM-2400 is in Single LED Mode. The Red and Green LED lines are active low digital I/O lines. The LED lines are in the normal state at 5V, and are in the active state when they are at 0V.

Dual LED Mode

In Dual LED Mode the Red and Green LED lines are enabled and there are four possible LED states; RED, GREEN, AMBER, and OFF. The table below shows the different states of the Red and Green LED lines and how those states correspond to the LED color. The default LED state, when no LED lines are asserted, is OFF.

Command Color	Red LED Line State	Green LED Line State
OFF	Normal	Normal
RED	Active	Normal
GREEN	Normal	Active
AMBER	Active	Active

Single LED Mode

In Single LED Mode the Red LED line is enabled and the Green LED line is disabled. There are two possible LED states; RED and GREEN. The OSDP spec does not allow a PD (OSM-2400) to NAK an LED command with the color OFF, so in this case the OSM-2400 will put the Red LED line in the normal state. The table below shows the different states of the Red LED line and how those states correspond to the LED color. The normal state is RED and the active state is GREEN.

Command Color	Red LED Line State
OFF (RED)	Normal
RED	Normal
GREEN	Active

Cypress OSM-2400 Manual - LED Modes (Cont.)

When DIP switch 7 is ON, the state of the LED lines are inverted. The tables below show the state of the Red and Green LED Lines when DIP switch 7 is ON.

Dual LED Mode Red and Green LED Line States (DIP switch 7 ON / Inverted)

Command Color	Red LED Line State	Green LED Line State
OFF	Active	Active
RED	Normal	Active
GREEN	Active	Normal
AMBER	Normal	Normal

Single LED Mode Red and Green LED Line States (DIP switch 7 ON / Inverted)

Command Color	Red LED Line State
OFF (RED)	Active
RED	Active
GREEN	Normal

Cypress OSM-2400 Manual - Using Secure Channel Communication

Secure Channel Mode

The OSM-2400 is in Secure Channel Mode when DIP Switch 6 is ON or when the Secure Channel Base Key (SCBK) has been set by the user. While the OSM-2400 is in Secure Channel Mode, the OSM-2400 will limit its functionality until a Secure Channel session is established. If the SCBK has not been set by the user, the OSM-2400 uses the SCBK-D (default SCBK).

ACU Mode - When Secure Channel Mode is not active, the OSM-2400 will initiate an unencrypted session with the OSDP reader or PD (Peripheral Device). When Secure Channel Mode is active, the OSM-2400 will only attempt to establish a Secure Channel session with the PD.

PD Mode -When Secure Channel Mode is not active, the ACU (Access Control Unit) can initiate an unencrypted session or Secure Channel session with the OSM-2400. When Secure Channel Mode is active, the OSM-2400 will only process a subset of commands (listed below), until the ACU establishes a Secure Channel session with the OSM-2400.

- osdp_ID
- osdp_CAP
- osdp_COMSET
- osdp_CHLNG
- osdp_MFG

Setting the Secure Channel Base Key (SCBK)

From the factory, the OSM-2400 is loaded with the SCBK-D, as defined in the OSDP specification. The SCBK-D / SCBK is used to encrypt the data payload of OSDP messages while in a Secure Channel session. The OSM-2400 SCBK-D is 30 31 32 33 34 35 36 37 38 39 3A 3B 3C 3D 3E 3F (16 bytes in HEX) and is public.

IMPORTANT: It is strongly recommended that a new SCBK be set in the OSM-2400 when using Secure Channel communication in ACU Mode or PD Mode. The SCBK is set in while the OSM-2400 is in PD Mode. The OSM-2400 will only accept the osdp_KEYSET command while it is in a Secure Channel communication session with an ACU. This means the current SCBK must be known before a new SCBK can be set in the OSM-2400.

The ACU sends the osdp_KEYSET command with the new SCBK to the OSM-2400 while in a Secure Channel communication session. **It is best practice for the SCBK to be sent to the OSM-2400 out-of-band**, meaning the OSM-2400 is directly connected to the ACU over a short run of cable and not connected to the ACU over the OSDP network connection. If an attacker is able to listen in on the OSDP communication while the osdp_KEYSET command is sent from the ACU to the OSM-2400 in PD Mode, they will have the SCBK and be able to decrypt the OSDP messages.

Section continued on next page.

Cypress OSM-2400 Manual - Using Secure Channel Communication (Cont.)

Follow the steps below for setting the new SCBK.

1. Initiate OSDP session between ACU and OSM-2400 in PD Mode.
2. Start a Secure Channel session using the SCBK-D (or known SCBK).
3. Send the `odsp_KEYSET` command containing the new SCBK.
4. Reset the Secure Channel session now using the new SCBK.

Once the new SCBK is set, the OSM-2400 will use the new SCBK in both PD Mode and ACU Mode. The SCBK can be changed by putting the OSM-2400 in PD mode, establishing a Secure Channel communication setting with an ACU using the current SCBK, and having the ACU send an `odsp_KEYSET` command with the new SCBK. If the current SCBK is unknown, factory defaulting the OSM-2400 will override the current SCBK with the SCBK-D.

Using Secure Channel Communication

When DIP Switch 6 is ON, the OSM-2400 will only communicate with the ACU or PD in a Secure Channel Session.

ACU Mode - When DIP Switch 6 is OFF and the device is using the SCBK-D, the OSM-2400 will initiate an unencrypted communication session with the OSDP reader or PD. When DIP Switch 6 is ON or the SCBK is set, the OSM-2400 will only attempt to initiate an encrypted communication session with the OSDP reader or PD.

PD Mode - When DIP Switch 6 is OFF the ACU can initiate an unencrypted or Secure Channel communication session with the OSM-2400. When DIP Switch 6 is ON the OSM-2400 will refuse to start an unencrypted communication session with the ACU and will only start a Secure Channel communication session with the ACU.

Section continued on next page.

Cypress OSM-2400 Manual - Using Secure Channel Communication (Cont.)

Unknown Secure Channel Base Key (SCBK)

If the OSM-2400 will not communicate with an ACU or PD because of an unknown SCBK, the device can be reset to use SCKB-D using a manufacturer specific command (osdp_MFG).

IMPORTANT: The OSM-2400 must be in PD Mode and the device address and baud rate must be known in order for the PD (OSM-2400) to receive the osdp_MFG command from the ACU. If the device address is unknown, the opsd_COMSET command can be sent using the broadcast address 127 (7F Hex). If the osdp_COMSET command is used with the broadcast address, it is important that the OSM-2400 is the only device on the OSDP bus. If more than one device is on the OSDP bus all of them will process the osdp_COMSET command and multiple device will be set to the new device address, causing communication issues on the OSDP bus. There is no way to discover the current OSM-2400 baud rate outside of trying to communicate with the OSM-2400 on each baud rate until successful. However, the OSM-2400 supports only 6 baud rates (see Specification Table).

The odsp_MFG command used to reset to the SCBK is a specific packet that must be sent 10 times in a row. During this process the sequence number (SQN) must always be 0. DO NOT increment the sequence (SQN) number in the 10 osdp_MFG commands or the SCBK reset will not work. Additionally, the osdp_MFG command must be the first command sent to the OSM-2400 by the ACU. If the OSM-2400 has received any other command before the osdp_MFG command, it will not be processed.

The osdp_MFG command is 13 bytes (Hex): FF 53 **XX** 0C 00 **YY** 80 CA 44 6C 05 **ZZ ZZ**

The bytes in bold are variable, below is an explanation of what these bytes are/can be.

XX: Address of target device (OSM-2400)

YY: Control Byte (04 if using CRC or 00 if using checksum)

ZZ ZZ: Message check characters (2 bytes if using CRC or 1 byte is using checksum)

The least significant two bits of the Control Byte are the sequence number (SQN), which must always be 0.

The data payload of the osdp_MFG command is 4 bytes (Hex): CA 44 6C 05

CA446C is Cypress Integration Solutions' IEEE OUI (Organizationally Unique Identifier). 05 is the Cypress Key Default command code.

Example osdp_MFG command: FF 53 00 0C 00 04 CA 44 6C 05 FC E2

Cypress OSM-2400 Manual - ACU Mode I/O Overview

In ACU Mode (Access Control Unit) the OSM-2400 is typically connecting an OSDP reader to a Wiegand access controller. General descriptions and functionality of the OSM-2400 I/O in ACU mode are below.

Wiegand Output - When the OSM-2400 receives a `osdp_RAW` or `osdp_KEYPAD` reply from the PD (Peripheral Device), it will output the credential data over the Wiegand interface to the Wiegand access controller. The OSM-2400 supports up to 1024 bits of credential data. The Wiegand Output lines support a signal voltage of 5V only. The Wiegand lines are floating (no pull-ups).

Buzzer Input - The Buzzer input is an active low digital input. The normal state is high (5V) and the active state is low (0V). When the Buzzer input is activated the `osdp_BUZ` command (on, continuous) will be sent to the PD. When deactivated the `osdp_BUZ` command (off, continuous) will be sent to the PD. The Buzzer Input line supports a signal voltage of 5V only. The Buzzer Input is floating (no pull-ups).

Relay - In ACU Mode, the dry contact relay output acts as a tamper output (supervision) for the OSDP reader (PD). The relay is in the alarm state when the OSM-2400 is not communicating with the PD, and in the normal state when the OSM-2400 is communicating with the PD. If the PD indicates a tamper state with the `LSTATR` reply the relay will change to the alarm state. If the PD sends the `LSTATR` reply indicating the tamper state is no longer present, the relay will change to the normal state.

Relay Normal State: continuity between Strike COM and Strike N.O. (normally open).

Relay Alarm State: continuity between Strike COM and Strike N.C. (normally closed).

Section continued on next page.

Cypress OSM-2400 Manual - ACU Mode I/O Overview (Cont.)

Red and Green LED Inputs - The Red and Green LED lines are active low digital inputs. The normal state is high (5V) and the active state is low (0V). The Red and Green LED lines connect to the LED outputs on the Wiegand access controller. The Wiegand access controller controls the state of the Red and Green LED lines on the OSM-2400, based on the state of the LED inputs the OSM-2400 sends an `osdp_LED` command to the OSDP reader to change the LED color appropriately. The Red and Green LED Inputs support a signal voltage of 5V only. The Red and Green LED Inputs are floating (no pull-ups).

Dual LED Mode (DIP Switch 4 OFF) is used when the OSM-2400 is used with a Wiegand access controller that has two LED control lines (typically Red and Green LED lines). Dual LED Mode allows for four LED states (RED, GREEN, AMBER, and OFF). When the OSM-2400 first establishes an OSDP session with the OSDP reader or PD, it will send an `osdp_LED` command to set the OSDP reader's LED to the color that corresponds to the current state of the Red and Green LED inputs.

Single LED Mode (DIP Switch 4 ON) is used when the OSM-2400 is used with a Wiegand access controller that has a single LED control line. Single LED Mode allows for two LED states (RED and GREEN). When the OSM-2400 first establishes an OSDP session with the OSDP reader or PD, it will send an `osdp_LED` command to set the OSDP reader's LED to the color that corresponds to the current state of the Red LED input.

The tables below show how the color in the `osdp_LED` command relates to the state of the LED inputs in Dual LED Mode and Single LED Mode.

Dual LED Mode

Command Color	Red LED Input State	Green LED Input State
OFF	Normal	Normal
RED	Active	Normal
GREEN	Normal	Active
AMBER	Active	Active

Single LED Mode

Command Color	Red LED Input State
RED	Normal
GREEN	Active

The RED LED Input and Green LED Input states are inverted when DIP switch 7 is ON.

Cypress OSM-2400 Manual - ACU Mode LED Commands - Red LED Input

Dual LED Mode: When the Red LED input is pulled low (0V) by the Wiegand access controller and the Green LED input is normal (5V), the OSM-2400 will send an osdp_LED command to set the OSDP reader's LED to red permanently.

When the Red LED input returns to the normal state (5V) and the Green LED input is normal (5V), the OSM-2400 will send an osdp_LED command to set the OSDP readers's LED to off permanently.

Single LED Mode: When the Red LED input is in the normal state (5V) the OSM-2400 will send an osdp_LED command to set the OSDP reader's LED to red permanently.

Red LED Command Payload (in HEX): 69 00 00 00 00 00 01 00 00 00 01 01 00 01 00

The table below shows the breakdown of the 15 byte payload.

Field Name	Value (in HEX)	Meaning
Command	69	1 byte - LED Command
Reader Number	00	1 byte - Reader Number 0
LED Number	00	1 byte - LED Number 0
Temporary Code	00	1 byte - Skip Temporary Settings
Temporary On Time (in 100 ms)	00	1 byte - Temporary LED On Time of 0 ms
Temporary Off Time (in 100 ms)	00	1 byte - Temporary LED Off Time of 0 ms
Temporary On Color	01	1 byte - Temporary LED On Color is Red
Temporary Off Color	00	1 byte - Temporary LED Off Color Black / Off
Temporary Timer (in 100 ms)	0000	2 bytes - Skip Temporary Settings
Permanent Code	01	1 byte - Use Permanent Settings
Permanent On Time (in 100 ms)	01	1 byte - Permanent LED On Time is 100 ms
Permanent Off Time (in 100 ms)	00	1 byte - Permanent LED Off Time is 0 ms
Permanent On Color	01	1 byte - Permanent LED On Color is Red
Permanent Off Color	00	1 byte - Permanent LED Off Color is Black / Off

Cypress OSM-2400 Manual - ACU Mode I/O - Green LED Input

Dual LED Mode: When the Green LED input is pulled low (0V) by the Wiegand access controller and the Red LED input is normal (5V), the OSM-2400 will send an osdp_LED command to set the OSDP reader's LED to green permanently.

When the Green LED input returns to the normal state (5V) and the Red LED input is normal (5V), the OSM-2400 will send an osdp_LED command to set the OSDP readers's LED to off permanently.

Single LED Mode: When the Red LED input is in the active state (0V) the OSM-2400 will send an osdp_LED command to set the OSDP reader's LED to green permanently.

Green LED Command Payload (in HEX): 69 00 00 00 00 00 02 00 00 00 01 01 00 02 00

The table below shows the breakdown of the 15 byte payload.

Field Name	Value (in HEX)	Meaning
Command	69	1 byte - LED Command
Reader Number	00	1 byte - Reader Number 0
LED Number	00	1 byte - LED Number 0
Temporary Code	00	1 byte - Skip Temporary Settings
Temporary On Time (in 100 ms)	00	1 byte - Temporary LED On Time of 0 ms
Temporary Off Time (in 100 ms)	00	1 byte - Temporary LED Off Time of 0 ms
Temporary On Color	02	1 byte - Temporary LED On Color is Green
Temporary Off Color	00	1 byte - Temporary LED Off Color Black / Off
Temporary Timer (in 100 ms)	0000	2 bytes - Skip Temporary Settings
Permanent Code	01	1 byte - Use Permanent Settings
Permanent On Time (in 100 ms)	01	1 byte - Permanent LED On Time is 100 ms
Permanent Off Time (in 100 ms)	00	1 byte - Permanent LED Off Time is 0 ms
Permanent On Color	02	1 byte - Permanent LED On Color is Green
Permanent Off Color	00	1 byte - Permanent LED Off Color is Black / Off

Cypress OSM-2400 Manual - ACU Mode I/O - Amber LED Input

Dual LED Mode: When both the Green and Red LED inputs are pulled low (0V) by the Wiegand access controller, the OSM-2400 will send an osdp_LED command to set the OSDP reader's LED to amber permanently.

When the Green and Red LED inputs return to the normal state (5V), the OSM-2400 will send an osdp_LED command to set the OSDP readers's LED to off permanently.

Single LED Mode: The amber LED color is not supported in Single LED Mode, the OSM-2400 will only send osdp_LED commands to set the OSDP reader's LED to red or green.

Amber LED Command Payload (in HEX): 69 00 00 00 00 00 03 00 00 00 01 01 00 03 00

The table below shows the breakdown of the 15 byte payload.

Field Name	Value (in HEX)	Meaning
Command	69	1 byte - LED Command
Reader Number	00	1 byte - Reader Number 0
LED Number	00	1 byte - LED Number 0
Temporary Code	00	1 byte - Skip Temporary Settings
Temporary On Time (in 100 ms)	00	1 byte - Temporary LED On Time of 0 ms
Temporary Off Time (in 100 ms)	00	1 byte - Temporary LED Off Time of 0 ms
Temporary On Color	03	1 byte - Temporary LED On Color is Amber
Temporary Off Color	00	1 byte - Temporary LED Off Color Black / Off
Temporary Timer (in 100 ms)	0000	2 bytes - Skip Temporary Settings
Permanent Code	01	1 byte - Use Permanent Settings
Permanent On Time (in 100 ms)	01	1 byte - Permanent LED On Time is 100 ms
Permanent Off Time (in 100 ms)	00	1 byte - Permanent LED Off Time is 0 ms
Permanent On Color	03	1 byte - Permanent LED On Color is Amber
Permanent Off Color	00	1 byte - Permanent LED Off Color is Black / Off

Cypress OSM-2400 Manual - ACU Mode I/O - OFF LED Input

Dual LED Mode: When both the Green and Red LED inputs are normal (5V), the OSM-2400 will send an `osdp_LED` command to set the OSDP reader's LED to off permanently.

Single LED Mode: The off LED color is not supported in Single LED Mode, the OSM-2400 will only send `osdp_LED` commands to set the OSDP reader's LED to red or green.

Off LED Command Payload (in HEX): 69 00 00 00 00 00 01 00 00 00 01 00 01 01 00

The table below shows the breakdown of the 15 byte payload.

Note: The color specified in the LED command is red, however, the Permanent On Time field is 0 ms and the Permanent Off Time field is 100ms. This means that the LED will never be turned on and will always be off.

Field Name	Value (in HEX)	Meaning
Command	69	1 byte - LED Command
Reader Number	00	1 byte - Reader Number 0
LED Number	00	1 byte - LED Number 0
Temporary Code	00	1 byte - Skip Temporary Settings
Temporary On Time (in 100 ms)	00	1 byte - Temporary LED On Time of 0 ms
Temporary Off Time (in 100 ms)	00	1 byte - Temporary LED Off Time of 0 ms
Temporary On Color	01	1 byte - Temporary LED On Color is Red
Temporary Off Color	00	1 byte - Temporary LED Off Color Black / Off
Temporary Timer (in 100 ms)	0000	2 bytes - Skip Temporary Settings
Permanent Code	01	1 byte - Use Permanent Settings
Permanent On Time (in 100 ms)	00	1 byte - Permanent LED On Time is 0 ms
Permanent Off Time (in 100 ms)	01	1 byte - Permanent LED Off Time is 100 ms
Permanent On Color	01	1 byte - Permanent LED On Color is Red
Permanent Off Color	00	1 byte - Permanent LED Off Color is Black / Off

Cypress OSM-2400 Manual - ACU Mode I/O - Buzzer Input

When the Buzzer Input is pulled low (0V) the OSM-2400 will send an osdp_BUZ command to the OSDP reader to activate the reader's buzzer.

BUZ On Raw Command Payload (in HEX): 6A 00 02 01 00 00

The table below shows the breakdown of the 6 byte payload.

Field Name	Value (in HEX)	Meaning
Command	6A	1 byte - BUZ Command
Reader Number	00	1 byte - Reader Number 0
Tone Code	02	1 byte - Tone set to On
On Time	01	1 byte - Tone On Time is 100 ms
Off Time	00	1 byte - Tone Off Time is 0 ms
Count	00	1 byte - Repeat Tone On and Off Time Forever

When the Buzzer Input returns to the normal state (5V) the OSM-2400 will send an osdp_BUZ command to the OSDP reader to deactivate the reader's buzzer.

BUZ Off Raw Command Payload (in HEX): 6A 00 01 05 05 00

The table below shows the breakdown of the 6 byte payload.

Field Name	Value (in HEX)	Meaning
Command	6A	1 byte - BUZ Command
Reader Number	00	1 byte - Reader Number 0
Tone Code	01	1 byte - Tone set to Off
On Time	05	1 byte - Tone On Time is 500 ms
Off Time	05	1 byte - Tone Off Time is 500 ms
Count	00	1 byte - Repeat Tone On and Off Time Forever

Cypress OSM-2400 Manual - PD Mode I/O Overview

In PD Mode (Peripheral Device) the OSM-2400 is typically connecting a Wiegand reader to an OSDP ACU (Access Control Unit). General descriptions and functionality of the OSM-2400 I/O in PD mode are below.

Wiegand Input - The OSM-2400 accepts between 4 and 1024 bits of Wiegand Data. When Wiegand data is received from the Wiegand reader the OSM-2400 will send either an `osdp_RAW` reply or `osdp_KEYPAD` reply to the ACU depending on the data. If the OSM-2400 receives 4 bits or 8 bits and the data matches keypad data the `osdp_KEYPAD` reply will be sent. If the 4 bits or 8 bits of data does not match keypad data or a different number of bits is received the `osdp_RAW` reply will be sent. Below is a table that shows the different keypad values the OSM-2400 accepts. The Wiegand Input lines support a signal voltage of 5V only. The Wiegand lines are floating (no pull-ups).

Keypad Value	0	1	2	3	4	5	6	7	8	9	Delete	Enter (Return)
Wiegand Data Received (4 bit)	0x0	0x1	0x2	0x3	0x4	0x5	0x6	0x7	0x8	0x9	0xA	0xB
Wiegand Data Received (8 bit)	0xF0	0xE1	0xD2	0xC3	0xB4	0xA5	0x96	0x87	0x78	0x69	0x5A	0x4B
osdp_KEYPAD Reply Data Field	0x30	0x31	0x32	0x33	0x34	0x35	0x36	0x37	0x38	0x39	0x7F	0x0D

Buzzer Output - The Buzzer output is an active low digital output. The normal state is high (5V) and the active state is low (0V). The state of the Buzzer output is controlled by the `osdp_BUZZ` command. The OSM-2400 supports `osdp_BUZZ` command timing and tone codes. The Buzzer Output line supports a signal voltage of 5V only. The Buzzer Output is floating (no pull-ups).

Relay - The dry contact relay output is Output 0 and is controlled by the `osdp_OUT` command, timing is supported. The Relay has three contacts: Normally Closed, Common, and Normally Open. The normal state of the Relay is continuity between Normally Closed and Common. The active state of the Relay is continuity between Normally Open and Common.

Section continues on next page.

Cypress OSM-2400 Manual - PD Mode I/O Overview (Cont.)

Red and Green LED Outputs - The Red and Green LED lines are active low digital outputs. The normal state is high (5V) and the active state is low (0V). The Red and Green LED lines connect to the LED input lines on the Wiegand reader. The OSDP ACU sends LED commands to the OSM-2400. Based on the LED command the OSM-2400 changes the state of the Red and Green LED lines on the OSM-2400 accordingly. The Red and Green LED Outputs support a signal voltage of 5V only. The Red and Green Outputs are floating (no pull-ups).

Dual LED Mode (DIP Switch 4 OFF) is used when the OSM-2400 is used with Wiegand readers that have two LED control lines (typically Red and Green LED lines). Dual LED Mode allows for four LED states (RED, GREEN, AMBER and OFF).

Single LED Mode (DIP Switch 4 ON) is used when the OSM-2400 is used with Wiegand readers that have a single LED control line. Single LED Mode allows for two LED states (RED and GREEN).

Although, Single LED Mode does not support the OFF LED color, it is not proper for a PD (OSM-2400) to NAK an OFF osdp_LED command. The OSM-2400 will process the osdp_LED command with the LED color set to OFF the same as an osdp_LED command with the LED color set to RED, changing the state of the Red LED output to normal (5V).

The tables below show how the color in the osdp_LED command relates to the state of the LED outputs in Dual LED Mode and Single LED Mode.

Dual LED Mode

Command Color	Red LED Output State	Green LED Output State
OFF	Normal	Normal
RED	Active	Normal
GREEN	Normal	Active
AMBER	Active	Active

Single LED Mode

Command Color	Red LED Output State
OFF (RED)	Normal
RED	Normal
GREEN	Active

The RED LED Input and Green LED Input states are inverted when DIP switch 7 is ON.

Cypress OSM-2400 Manual - PD Mode I/O - Wiegand Input

The OSM-2400 accepts 4 bits and 8 - 1024 bits of Wiegand data from the Wiegand reader. When Wiegand data is received the OSM-2400 will reply with the osdp_RAW reply when it is next polled by the ACU (Access Control Unit). The example below shows a 32 bit credential.

RAW Reply Payload (in HEX): 50 00 01 20 00 12 34 56 78

The table below shows the breakdown of the 9 byte payload.

Field Name	Value (in HEX)	Meaning
Reply	50	1 byte - RAW Reply
Reader Number	00	1 byte - Reader Number 0
Format Code	01	1 byte - Format Code for Weigand
Bit Count	20 00	2 bytes - Number of Data Bits (little-endian)
Data	12 34 56 78	4 bytes - 32 Bits of Credential Data

When the OSM-2400 receives 4 or 8 bits of Wiegand data and the data matches the data in the “Wiegand Data Received” row of the below table, it will reply with the osdp_KEYPAD reply when it is next polled by the ACU. Each individual keypress on the keypad reader is 8 bits, which correlates to a single osdp_KEYPAD reply.

Keypad Value	0	1	2	3	4	5	6	7	8	9	Delete	Enter (Return)
Wiegand Data Received (4 bit)	0x0	0x1	0x2	0x3	0x4	0x5	0x6	0x7	0x8	0x9	0xA	0xB
Wiegand Data Received	0xF0	0xE1	0xD2	0xC3	0xB4	0xA5	0x96	0x87	0x78	0x69	0x5A	0x4B
osdp_KEYPAD Reply Data Field	0x30	0x31	0x32	0x33	0x34	0x35	0x36	0x37	0x38	0x39	0x7F	0x0D

KEYPAD Reply Payload (in HEX): 53 00 01 31

The table below shows the breakdown of the 4 byte payload.

Field Name	Value (in HEX)	Meaning
Reply	53	1 byte - KEYPAD Reply
Reader Number	00	1 byte - Reader Number 0
Digit Count	01	1 byte - KEYPAD Reply Contains 1 Digit
Digits	31	1 byte - ASCII Hex Data for 1

Cypress OSM-2400 Manual - Firmware Upload using File Transfer

The OSM-2400 supports uploading different firmware versions using OSDP File Transfer. This allows the device firmware to be upgraded without removing it from the field. The device address, baud rate, and SCBK will remain after the firmware upload is complete, which allows for a new OSDP communication session to be established automatically.

Below are a list of requirements necessary to perform the OSDP File Transfer.

- ACU (Access Control Unit) that supports OSDP File Transfer
- OSM-2400 must be in PD Mode (Peripheral Device)
- ACU and OSM-2400 must have established OSDP communication session
- Obtain/posses a valid Cypress OSM-2400 firmware file

The ACU will send the new firmware file to the OSM-2400 over the OSDP bus. After the firmware file has been sent to the OSM-2400, the device will apply the new firmware file and reboot, then the ACU can establish a new OSDP communication session with the OSM-2400. Depending on the baud rate the duration of the firmware upload process varies. At 9600 baud the firmware upload can take up to approximately 3 minutes. At 230400 baud the firmware upload can take up to approximately 15 seconds.