

Pendant Cap



Use the R2-PNDTCP201A pendant cap to conceal and protect cable when mounting video surveillance cameras to ceilings or pendant or wall mounts.

FEATURES

- VERSATILE CEILING, PENDANT AND WALL MOUNT COMPATIBILITY
- DURABLE ALUMINUM ALLOY
- PART #: R2-PNDTCP201A
- UPC: 840049305502

COMPATIBILITY

CAPTURE ADVANCE CAMERAS	HD: R2-HD5MPMOEY
CAPTURE ADVANCE MOUNTS	R2-PNDMT402, R2-WMT501, R2-WMT502

SPECIFICATIONS

MATERIAL	ALUMINUM ALLOY
DIMENSIONS	Ø4.83 × 2.76" (Ø122.8 × 70MM)
WEIGHT	0.55 LB (0.25KG)
LOAD BEARING CAPACITY	6.61 LB (3KG)
OPERATING HUMIDITY	0% - 90% RH

UNITS: MM

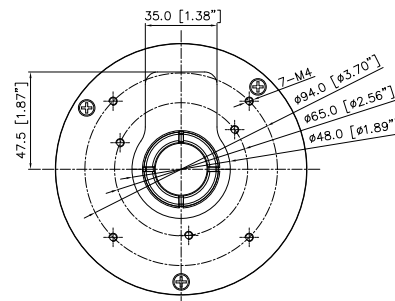
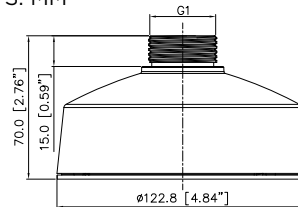

INSTALLATION NOTES

INSTALL ON FLAT SURFACE CAPABLE OF SUPPORTING OVER THREE TIMES THE WEIGHT OF THE CAMERA AND PENDANT CAP.

MAXIMUM LOAD BEARING CAPACITY OF PENDANT CAP IS 6.61 LB (3KG).

FOR MORE INFORMATION, CONTACT YOUR ADI SALES PERSON.