

NOTES:  
 1. MATERIAL OF CONSTRUCTION IS 304 SS, BRUSHED #4.



PEDESTALPRO.COM  
 1-800-660-3072

UNLESS OTHERWISE SPECIFIED:

DIMENSIONS ARE IN INCHES  
 TOLERANCES:  
 FRACTIONAL  $\pm 1/32$   
 ANGULAR:  $\pm 2^\circ$   
 TWO PLACE DECIMAL  $\pm 0.010$   
 THREE PLACE DECIMAL  $\pm 0.005$

INTERPRET GEOMETRIC  
 TOLERANCING PER:  
 ASME Y14.5 -2009

NAME DATE

DRAWN

CHECKED

**PROPRIETARY AND CONFIDENTIAL**

THE INFORMATION CONTAINED IN THIS  
 DRAWING IS THE SOLE PROPERTY OF  
 PEDESTALPRO LLC. ANY REPRODUCTION  
 IN PART OR AS A WHOLE WITHOUT THE  
 WRITTEN PERMISSION OF PEDESTALPRO LLC  
 IS PROHIBITED.

TITLE:

INSTALLATION

Friday, May 15, 2020  
 11:22:24 AM

WEIGHT: 65.405

SIZE  
**A**

PART NO.  
 84TOW-ZENI-01-304

REV  
**0**

NO SCALE

SHEET 1 OF 7

ITEM NO.	PART NUMBER	DESCRIPTION	QTY.
1	84TOW-ZENI-01-304	8 X 4 WELDMENT	1
2	PLTCAP-84-84-30	84-30 STANDARD CAP PLATE	1
3	PLTACC-510	STANDARD ACCESS COVER	1
4	PLTBAS-84-84	STANDARD BASE PLATE	1
5	--	8-32 PAN HEAD SCREW	4

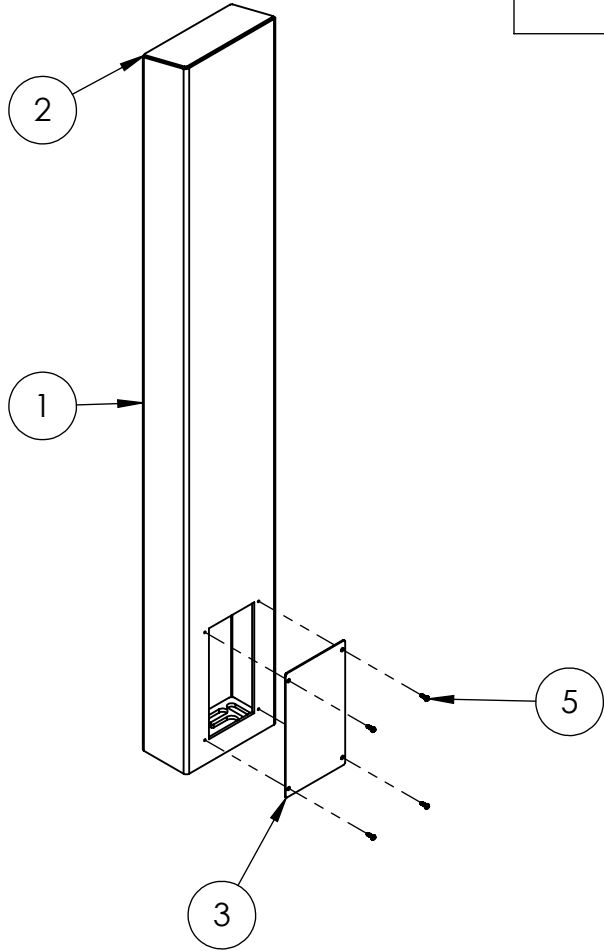

NOTES:

- SEE STANDARD PREPARATION AND COATING INSTRUCTIONS FOR COATING PROCEDURE AND COLOR.
- SEE STANDARD PACKAGING INSTRUCTIONS FOR PACKAGING PROCEDURE.



PEDESTALPRO.COM  
1-800-660-3072

UNLESS OTHERWISE SPECIFIED:

DIMENSIONS ARE IN INCHES  
TOLERANCES:  
FRACTIONAL  $\pm 1/32$   
ANGULAR:  $\pm 2^\circ$   
TWO PLACE DECIMAL  $\pm 0.010$   
THREE PLACE DECIMAL  $\pm 0.005$

INTERPRET GEOMETRIC  
TOLERANCING PER:  
ASME Y14.5 -2009

NAME	DATE
DRAWN	
CHECKED	

**PROPRIETARY AND CONFIDENTIAL**  
THE INFORMATION CONTAINED IN THIS  
DRAWING IS THE SOLE PROPERTY OF  
PEDESTALPRO LLC. ANY REPRODUCTION  
IN PART OR AS A WHOLE WITHOUT THE  
WRITTEN PERMISSION OF PEDESTALPRO LLC  
IS PROHIBITED.

TITLE:  
**ASSEMBLY**

Friday, May 15, 2020  
11:22:24 AM

WEIGHT: 65.405

SIZE	PART NO.	REV
<b>A</b>	84TOW-ZENI-01-304	<b>0</b>

NO SCALE

SHEET 2 OF 7