

SECTION A-A

PAXTON 010-296-US

NOTES:

1. MATERIAL OF CONSTRUCTION IS MILD STEEL.
2. 2-4 MILS BLACK WRINKLE POWDER COAT.

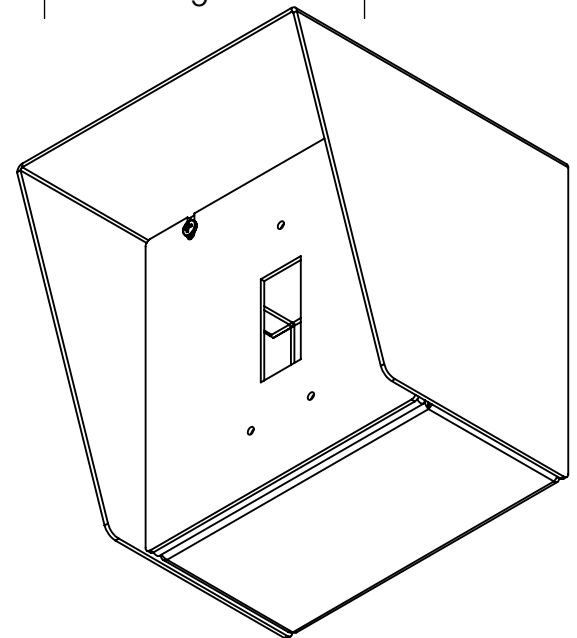

PEDESTALPRO.COM  
1-800-660-3072

UNLESS OTHERWISE SPECIFIED:

DIMENSIONS ARE IN INCHES  
TOLERANCES:  
FRACTIONAL  $\pm 1/32$   
ANGULAR:  $\pm 2^\circ$   
TWO PLACE DECIMAL  $\pm 0.010$   
THREE PLACE DECIMAL  $\pm 0.005$

INTERPRET GEOMETRIC  
TOLERANCING PER:  
ASME Y14.5 -2009

NAME	DATE
DRAWN	
CHECKED	
<b>PROPRIETARY AND CONFIDENTIAL</b>	
THE INFORMATION CONTAINED IN THIS DRAWING IS THE SOLE PROPERTY OF PEDESTALPRO LLC. ANY REPRODUCTION IN PART OR AS A WHOLE WITHOUT THE WRITTEN PERMISSION OF PEDESTALPRO LLC IS PROHIBITED.	

TITLE:  
**INSTALLATION**

Friday, May 19, 2023  
9:03:17 AM

WEIGHT: 5.312

SIZE	PART NO.	REV
<b>A</b>	66HOU-PAXT-03-CRS	<b>C</b>
NO SCALE		SHEET 1 OF 6

ITEM NO.	PART NUMBER	DESCRIPTION	QTY.
1	66HOU-PAXT-03-CRS ENCLOSURE	ENCLOSURE WELDMENT	1
2	66HOU-PAXT-03-CRS DOOR	DOOR WELDMENT	1
3	HINGE	PIANO HINGE	1
4	GASKET SIDE	3/8" X .150 WEATHERSTRIPPING	2
5	GASKET TOP	3/8" X .150 WEATHERSTRIPPING	1
6	--	6-32 PAN HEAD SCREW	4
7	--	6-32 EXTERNAL TOOTH LOCK NUT	2

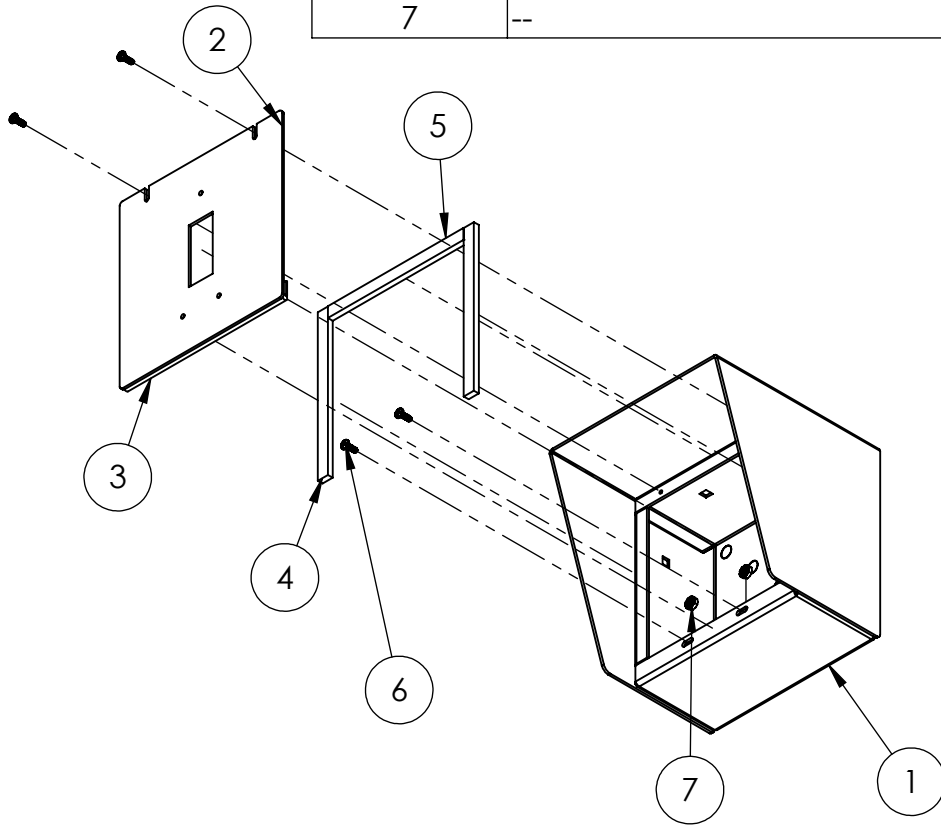

NOTES:

1. SEE STANDARD PREPARATION AND COATING INSTRUCTIONS FOR COATING PROCEDURE AND COLOR.
2. SEE STANDARD PACKAGING INSTRUCTIONS FOR PACKAGING PROCEDURE.



PEDESTALPRO.COM  
1-800-660-3072

UNLESS OTHERWISE SPECIFIED:

DIMENSIONS ARE IN INCHES  
TOLERANCES:  
FRACTIONAL  $\pm 1/32$   
ANGULAR:  $\pm 2^\circ$   
TWO PLACE DECIMAL  $\pm 0.010$   
THREE PLACE DECIMAL  $\pm 0.005$

INTERPRET GEOMETRIC  
TOLERANCING PER:  
ASME Y14.5 -2009

NAME DATE

DRAWN

CHECKED

**PROPRIETARY AND CONFIDENTIAL**

THE INFORMATION CONTAINED IN THIS  
DRAWING IS THE SOLE PROPERTY OF  
PEDESTALPRO LLC. ANY REPRODUCTION  
IN PART OR AS A WHOLE WITHOUT THE  
WRITTEN PERMISSION OF PEDESTALPRO LLC  
IS PROHIBITED.

TITLE:

**ASSEMBLY**

Tuesday, September  
11, 2018 9:34:19 AM

WEIGHT: 5.312

SIZE  
**A**

PART NO.  
66HOU-PAXT-03-CRS

REV  
**C**

NO SCALE

SHEET 2 OF 6