

PEDESTALPRO.COM  
1-800-660-3072

UNLESS OTHERWISE SPECIFIED:

DIMENSIONS ARE IN INCHES  
TOLERANCES:  
FRACTIONAL ± 1/32  
ANGULAR: ± 2°  
TWO PLACE DECIMAL ± 0.010  
THREE PLACE DECIMAL ± 0.005

INTERPRET GEOMETRIC TOLERANCING PER: ASME Y14.5 -2009

NAME	DATE
------	------

DRAWN	
CHECKED	

**PROPRIETARY AND CONFIDENTIAL**  
THE INFORMATION CONTAINED IN THIS DRAWING IS THE SOLE PROPERTY OF PEDESTALPRO LLC. ANY REPRODUCTION IN PART OR AS A WHOLE WITHOUT THE WRITTEN PERMISSION OF PEDESTALPRO LLC IS PROHIBITED.

TITLE:  
**INSTALLATION**

Thursday, October 25, 2018 3:57:46 PM

WEIGHT:

SIZE <b>A</b>	PART NO. 33PE1-PDK-03-304	REV <b>B</b>
------------------	------------------------------	-----------------

NO SCALE SHEET 1 OF 4

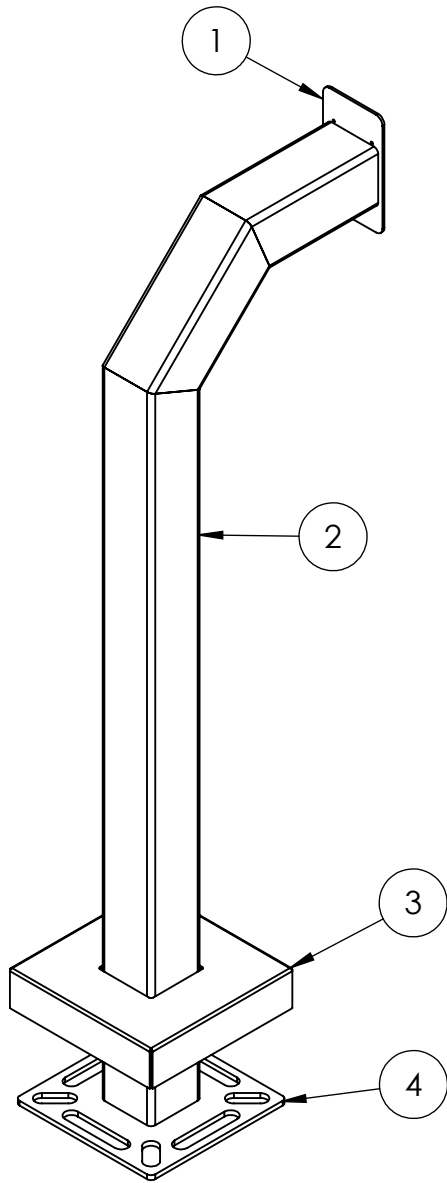

ITEM NO.	PART NUMBER	DESCRIPTION	QTY.
1	PLTFAC-RDRQR	MOUNTING PLATE	1
2	42-3-12-SS	3X3 SQ 304SS TUBE	1
3	PLTCOV-8-3	8" STANDARD 304SS COVER PLATE	1
4	PLTBAS-8-3	8" STANDARD 304SS BASE PLATE	1
5	--	1/4-20 X .50 ZINC PL CARRIAGE BOLT	4
6	--	1/4-20 ZINC PL HEX NUT	4

**NOTES:**

1. BUTT WELDED SECTIONS ARE NOT ALLOWED, EACH SECTION OF TUBE MUST BE FROM CONTINUOUS STOCK.
2. ALL WELDS ARE TO BE CONTINUOUS FILLET WELDS UNLESS NOTED OTHERWISE.
3. SEE STANDARD PREPARATION AND COATING INSTRUCTIONS FOR COATING PROCEDURE AND COLOR.
4. FASTENERS ARE TO BE BAGGED AND SHIPPED WITH PEDESTAL.
5. SEE STANDARD PACKAGING INSTUCTIONS FOR PACKAGING PROCEDURE.



PEDESTALPRO.COM  
1-800-660-3072

UNLESS OTHERWISE SPECIFIED:

DIMENSIONS ARE IN INCHES  
TOLERANCES:  
FRACTIONAL  $\pm 1/32$   
ANGULAR:  $\pm 2^\circ$   
TWO PLACE DECIMAL  $\pm 0.010$   
THREE PLACE DECIMAL  $\pm 0.005$

INTERPRET GEOMETRIC  
TOLERANCING PER:  
ASME Y14.5 -2009

NAME	DATE
DRAWN	
CHECKED	

**PROPRIETARY AND CONFIDENTIAL**

THE INFORMATION CONTAINED IN THIS DRAWING IS THE SOLE PROPERTY OF PEDESTALPRO LLC. ANY REPRODUCTION IN PART OR AS A WHOLE WITHOUT THE WRITTEN PERMISSION OF PEDESTALPRO LLC IS PROHIBITED.

TITLE:  
**ASSEMBLY**

Thursday, October 25,  
2018 3:57:46 PM

WEIGHT:

SIZE <b>A</b>	PART NO. 33PE1-PDK-03-304
------------------	------------------------------

REV <b>B</b>
-----------------

NO SCALE

SHEET 2 OF 4